

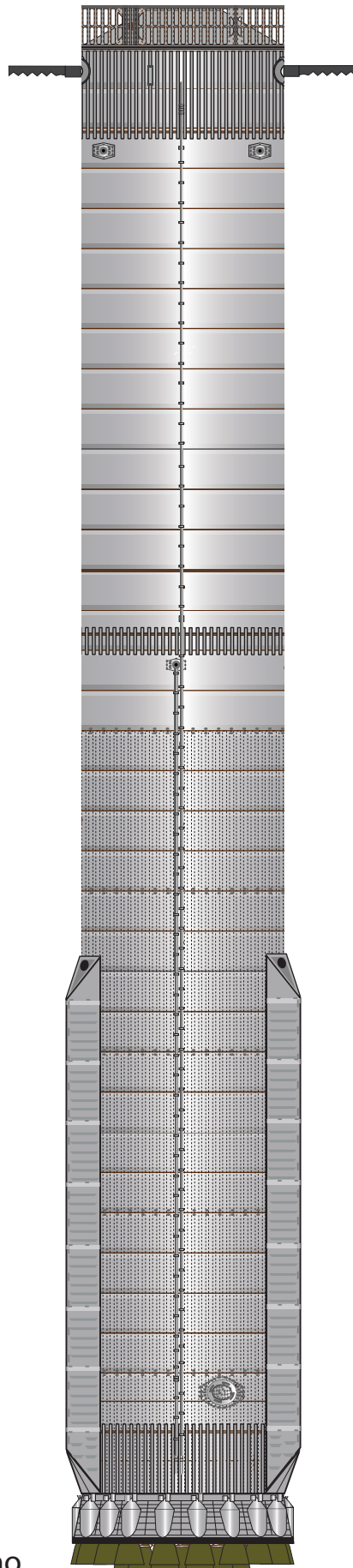

1:100 Scale

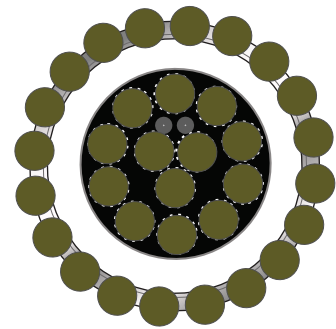

B10

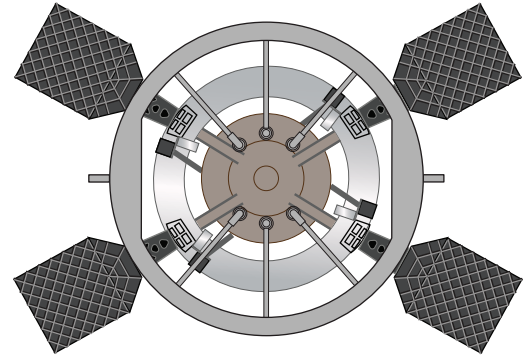
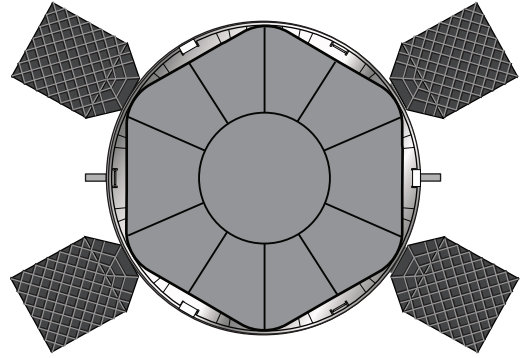

Designed by Alfonso X Moreno

©2024 Not for commercial use



1 cm

1 inch

1:100 Scale

Hot staging Ring

Print on Cardstock (110 lbs)

Top ring

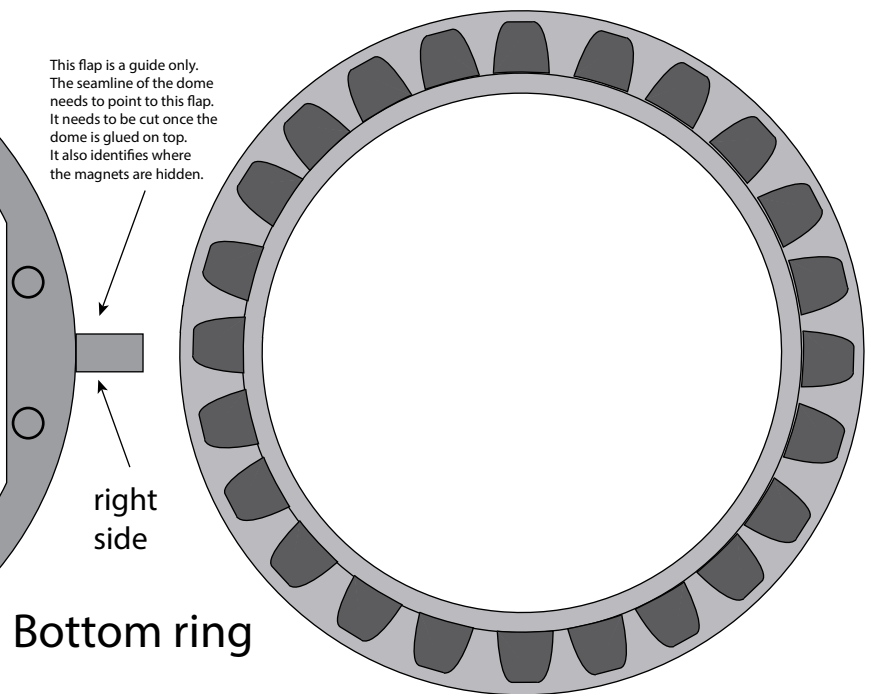
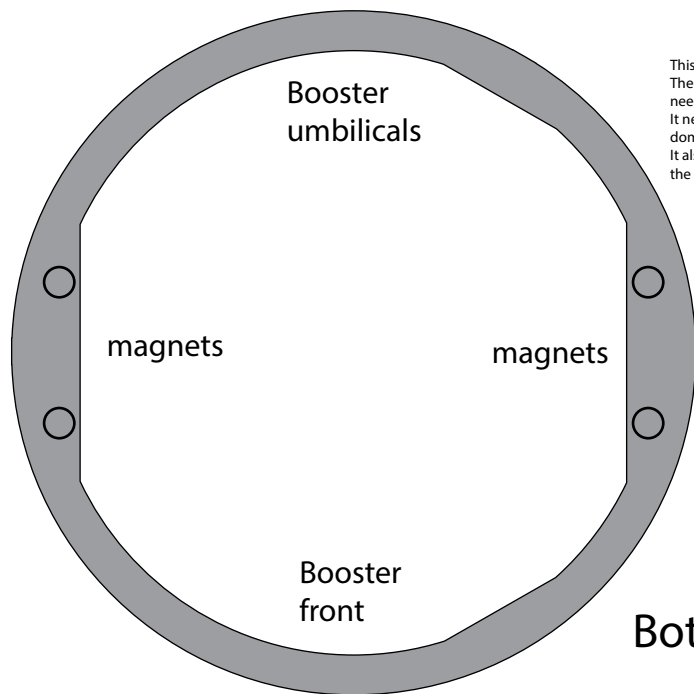
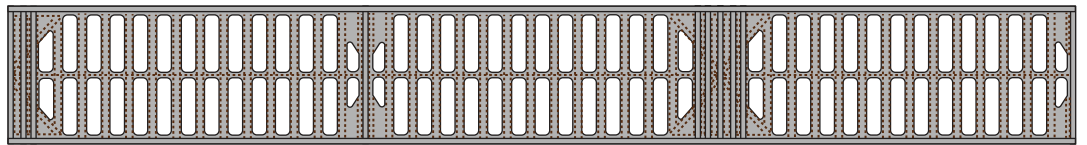
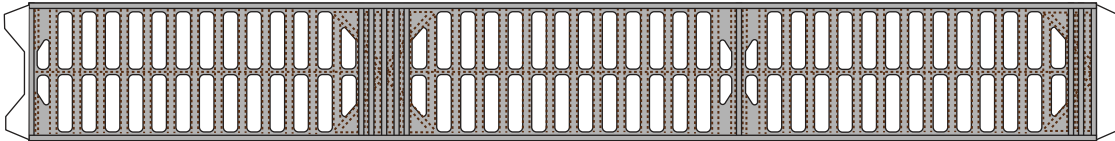
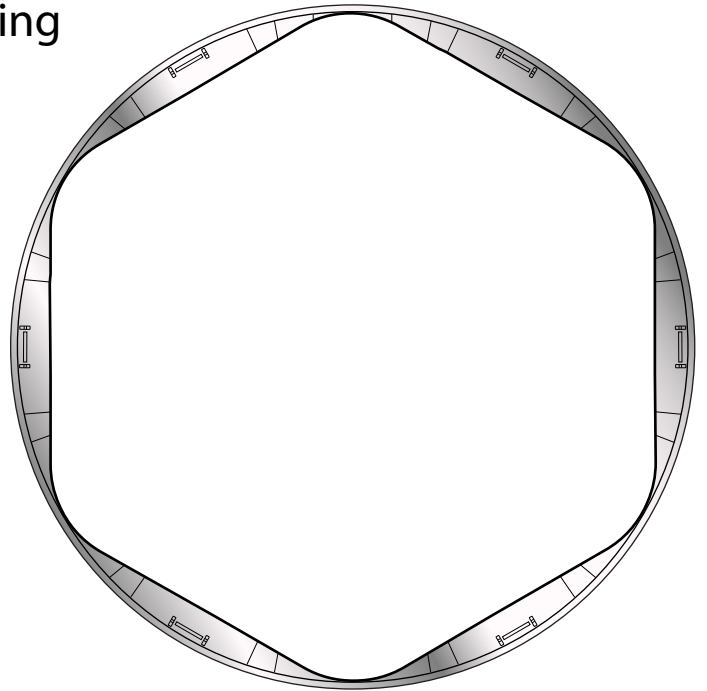
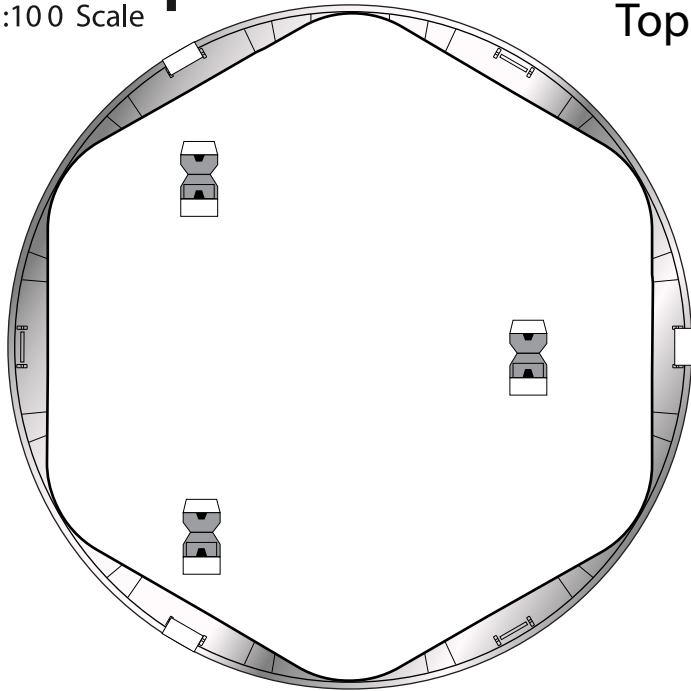

This flap is a guide only. The seamline of the dome needs to point to this flap. It needs to be cut once the dome is glued on top. It also identifies where the magnets are hidden.

Booster umbilicals

magnets

magnets

Booster front

right side

Bottom ring



1:100 Scale

Hot staging Ring

Print on Cardstock (110 lbs)

Back Print

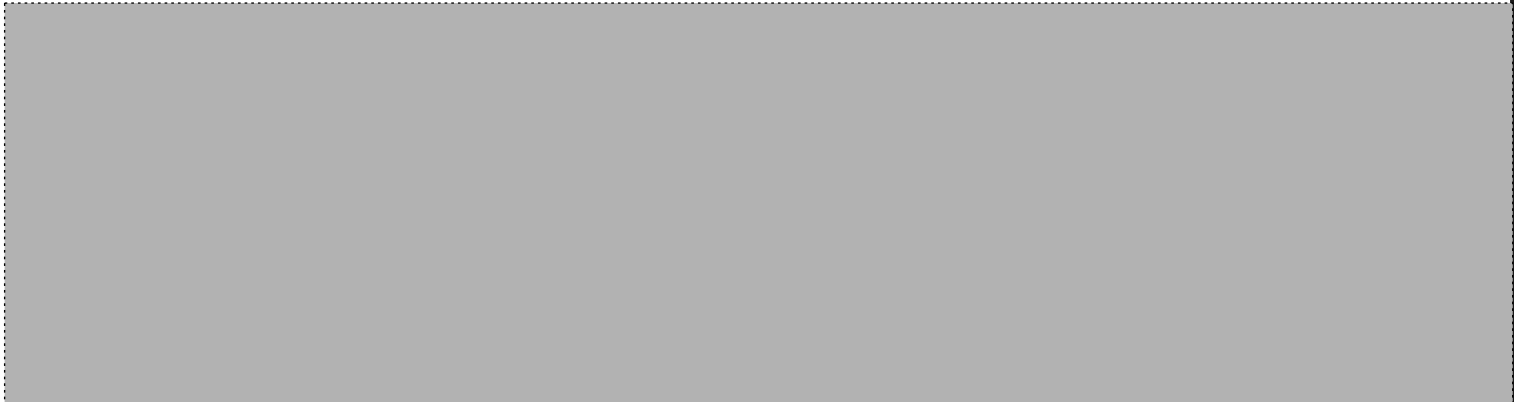



1 cm

1 inch

1:100 Scale

Hot staging Ring

Print on Cardstock (110 lbs)

Simple version

Exterior skin

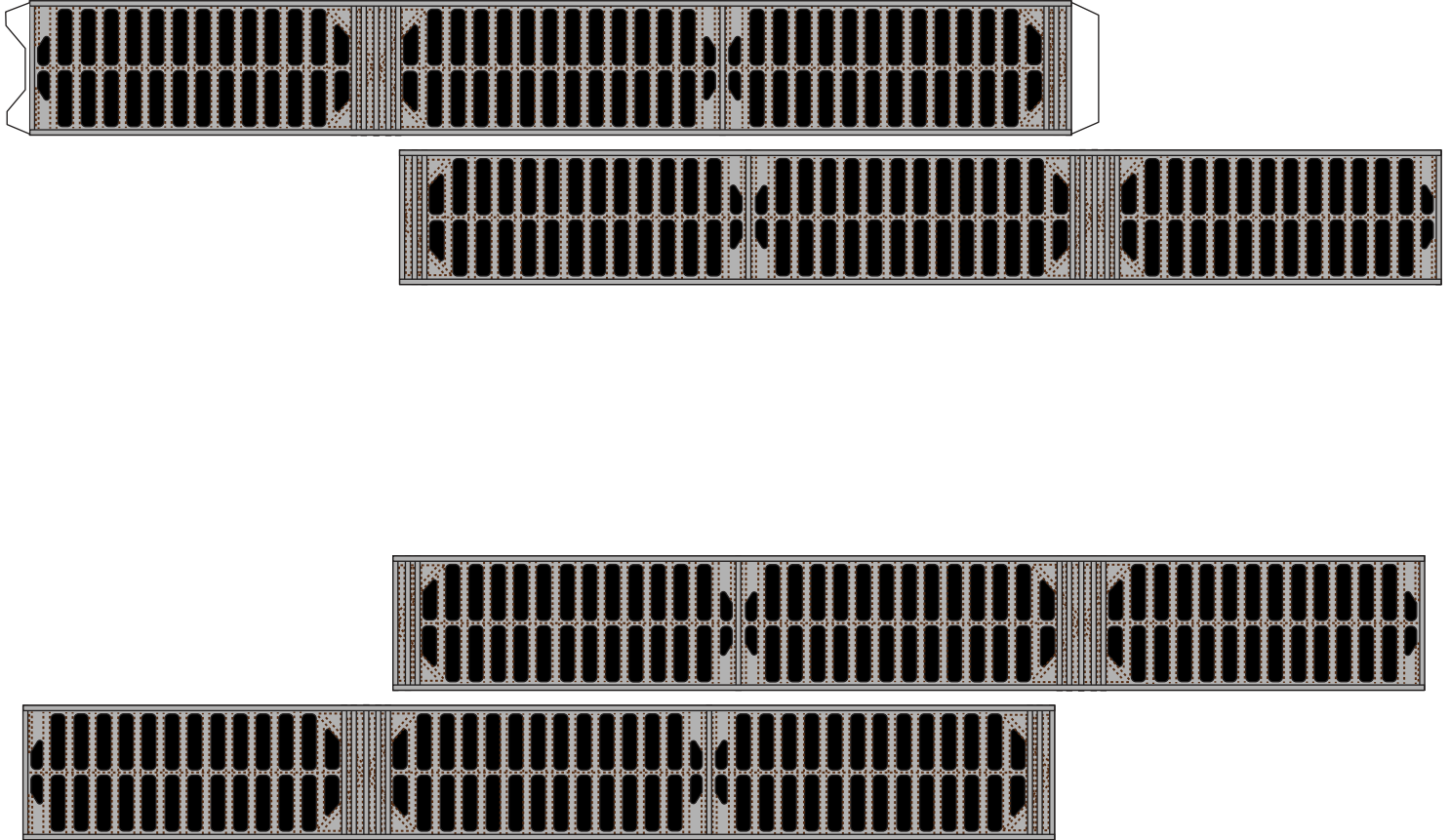

Interior skin



1 cm

1 inch

1:100 Scale

Hot staging Ring Dome

Print on Cardstock (110 lbs)

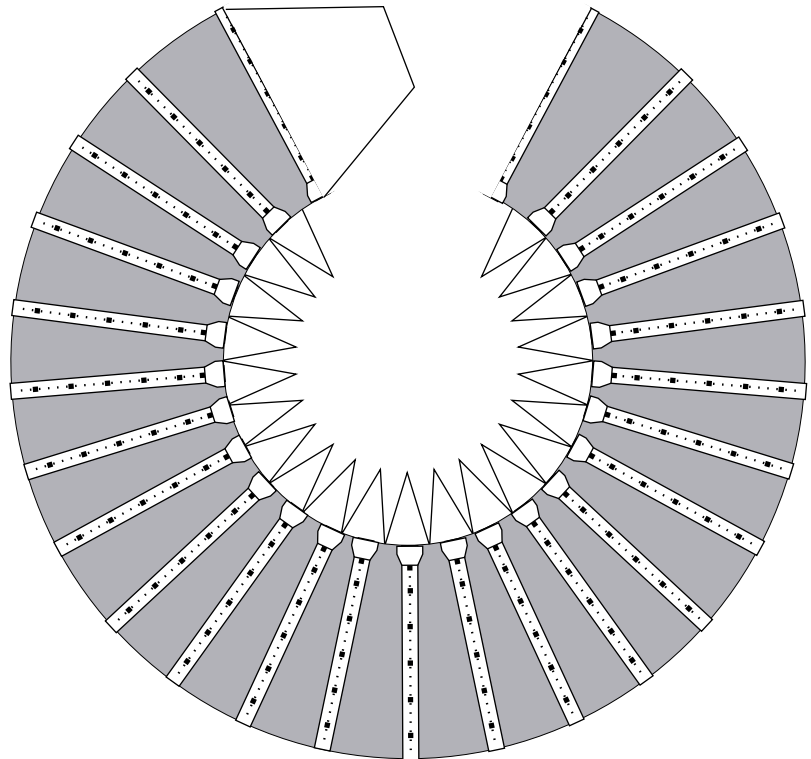
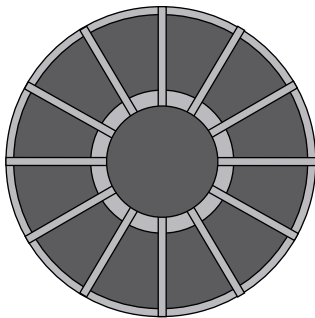
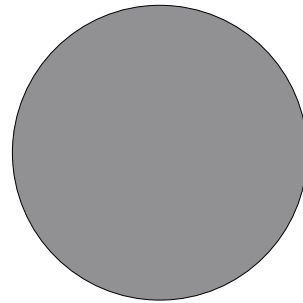
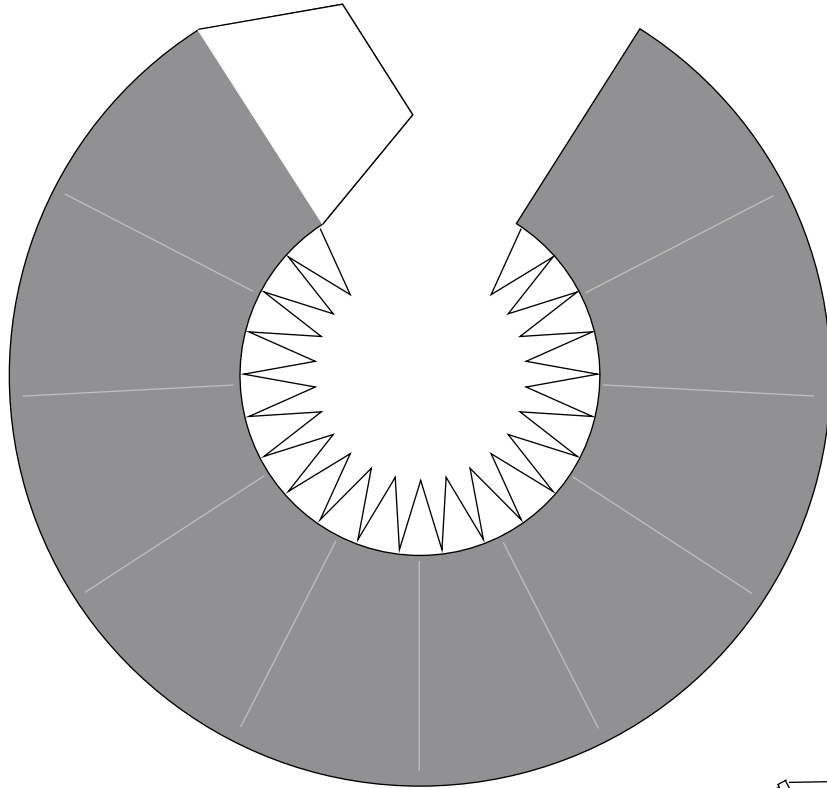



SpaceX SuperHeavy

Print on Cardstock (110 lbs)

1:100 Scale

Top ring

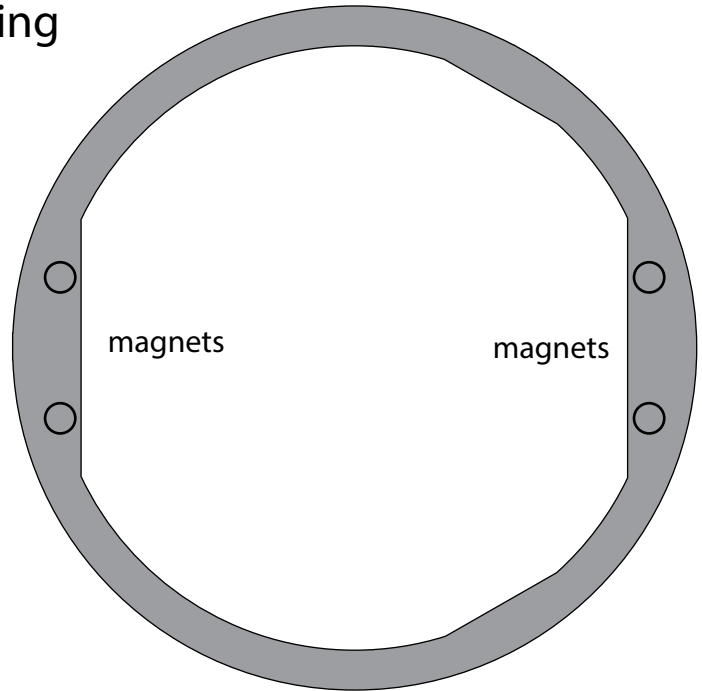
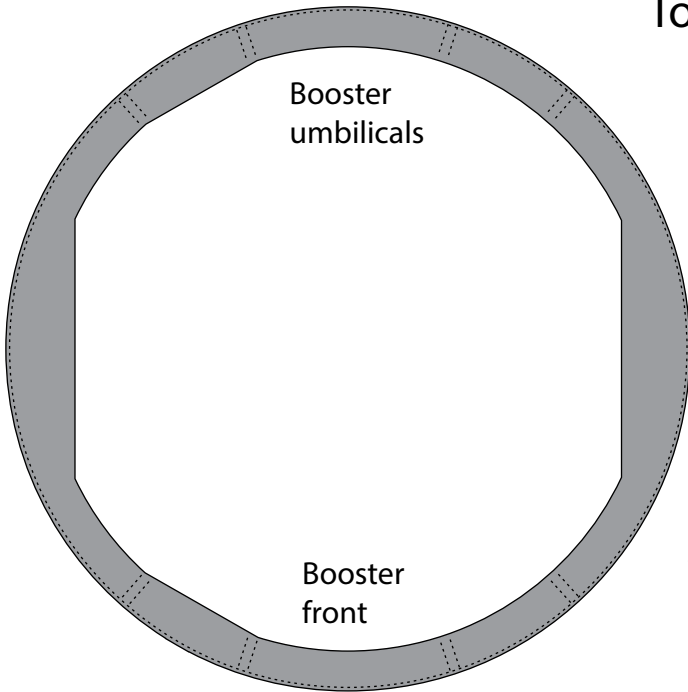

right side

Bottom ring

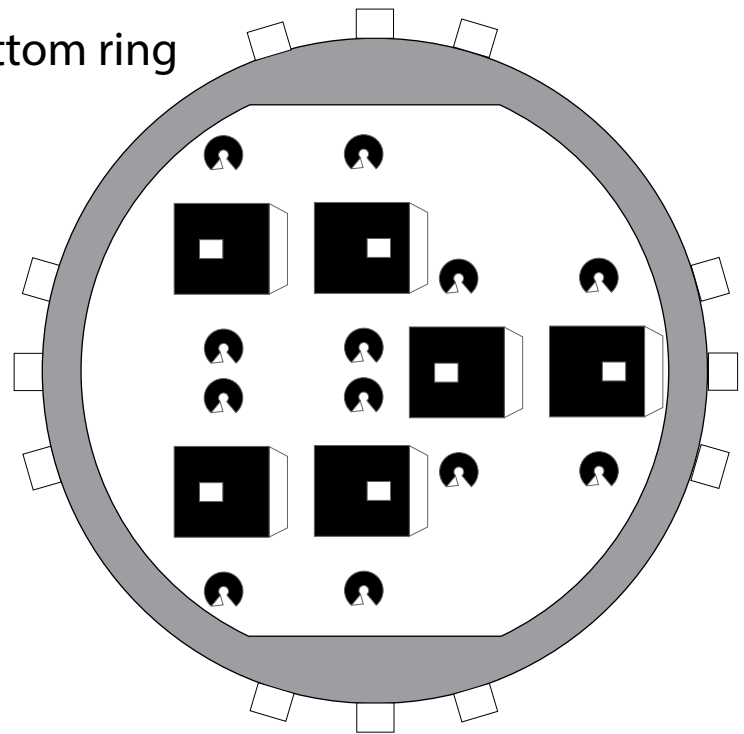
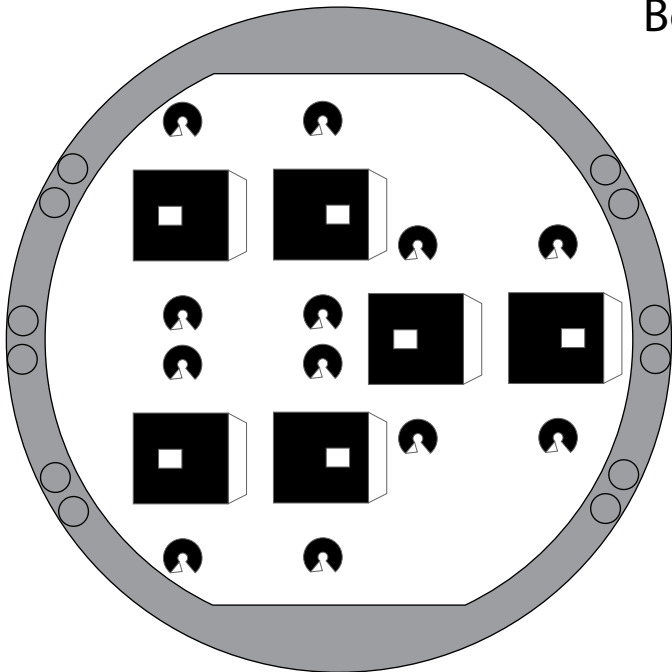

COPV pair
top and bottom supports



1 cm

1 inch

1:100 Scale

SuperHeavy B10 Upper Dome

Print on Cardstock (110 lbs)

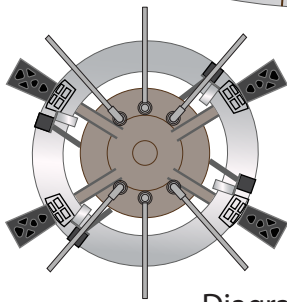
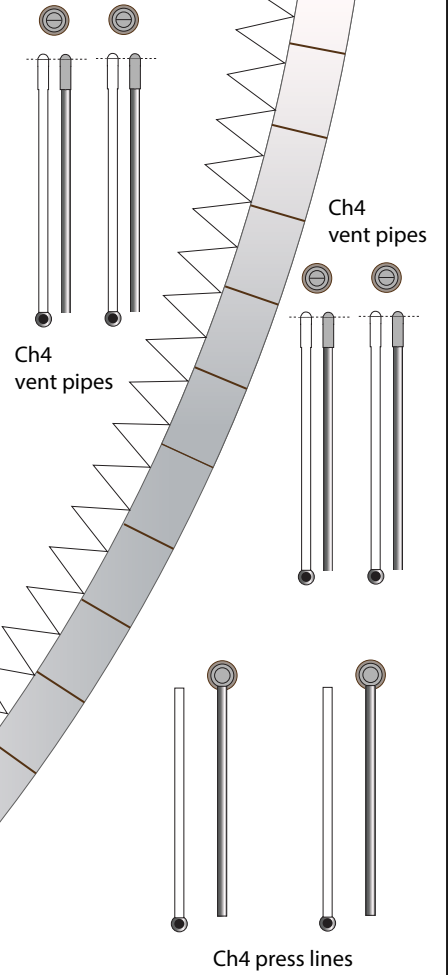
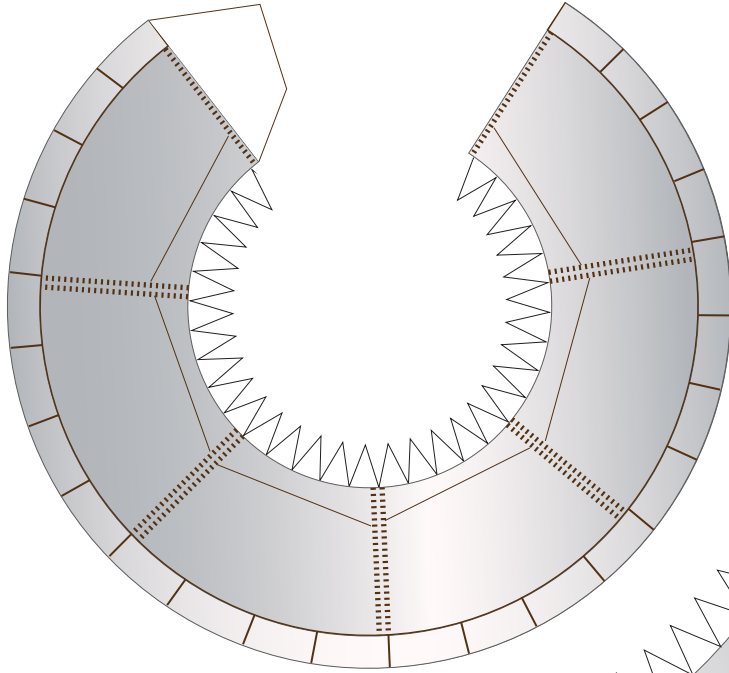
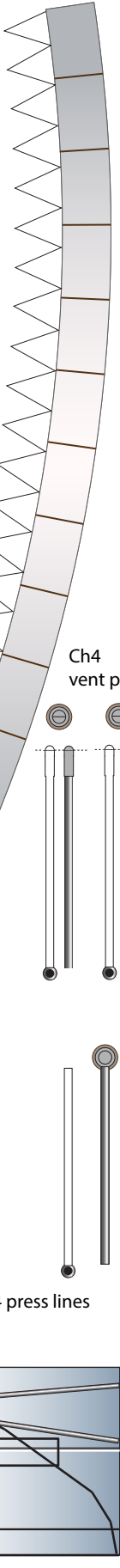
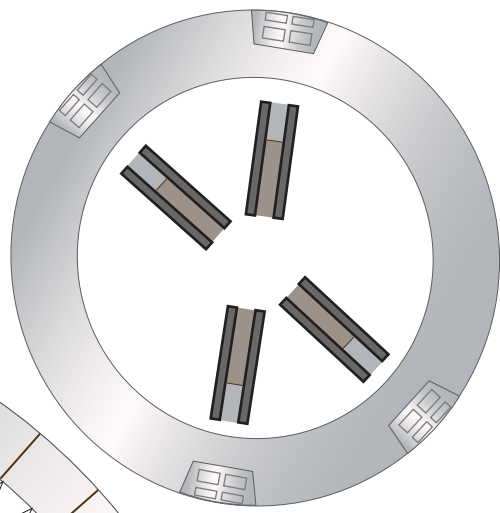
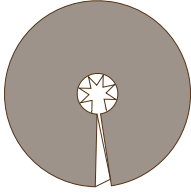
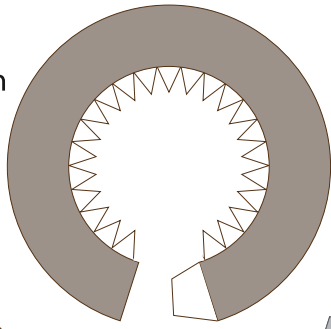

Diagram

Diagram

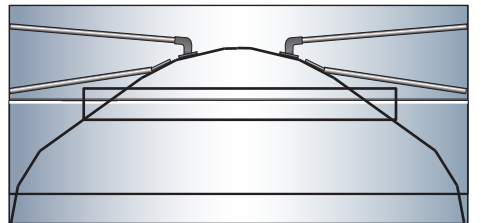



1 cm

SpaceX Starship B10

Print on Cardstock (110 lbs)

Grid Fins servo motors and Connectors for each body segment

1 inch

1:100 Scale

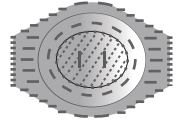
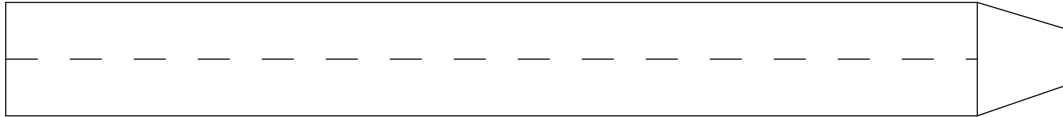
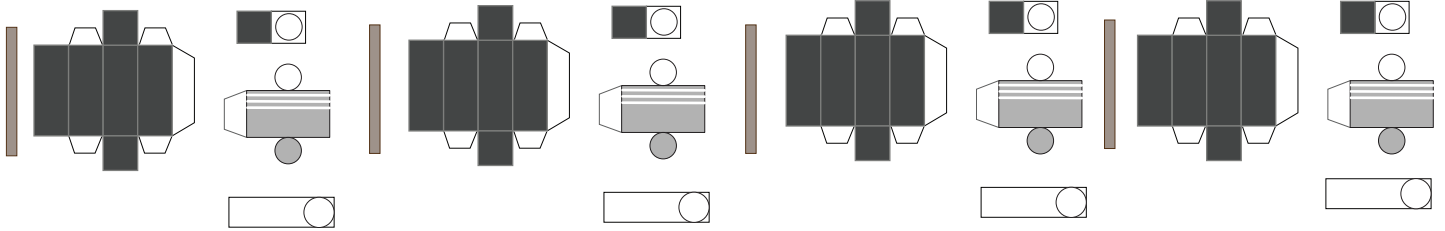

top/middle

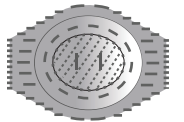
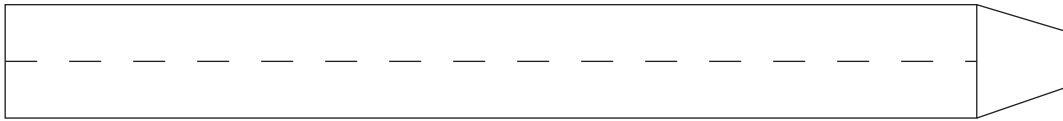
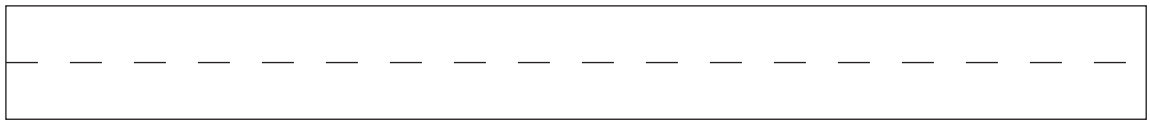

middle/bottom

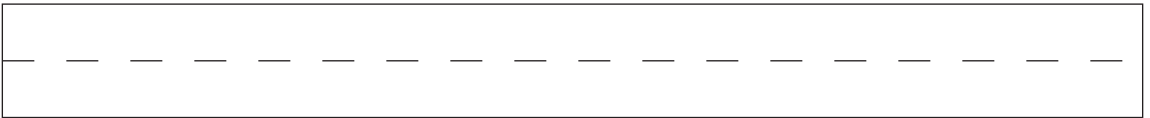

Glue tip of the
Ch4 press line to
cover the black circles

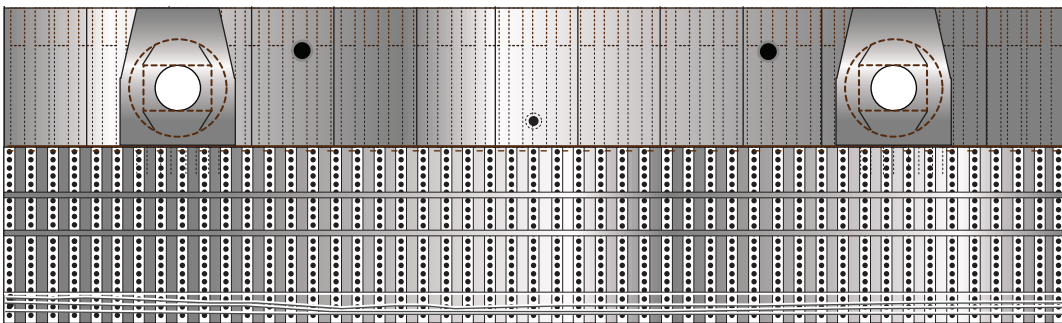
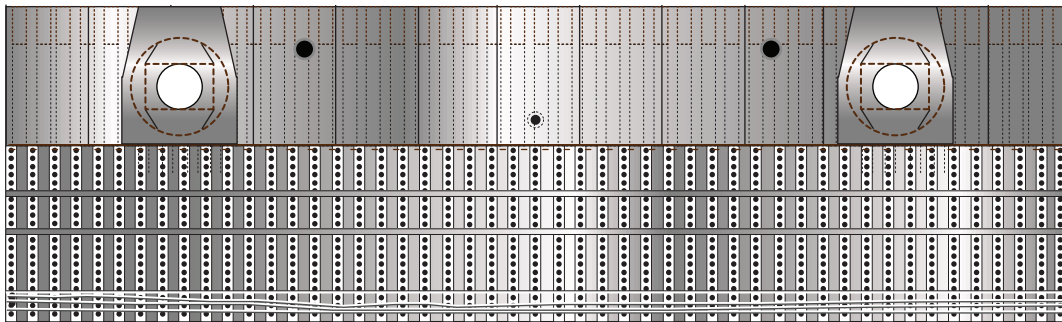

Interior wall
for upper dome
section



1 cm

1 inch

1:100 Scale

SuperHeavy B10 Grid Fins

Print on Cardstock (110 lbs)

Simple version

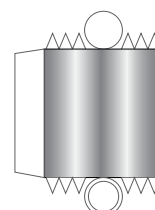
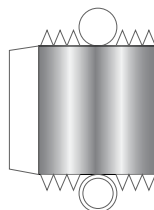
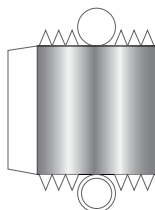
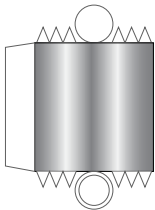
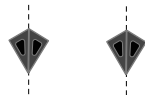
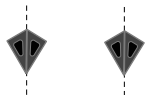
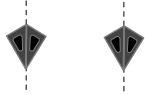
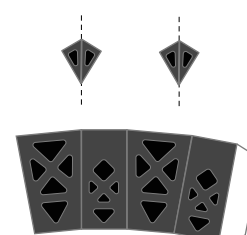
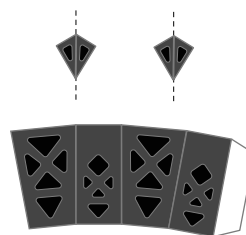
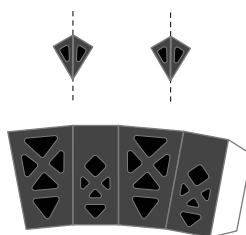
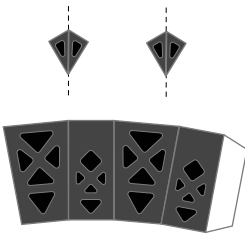
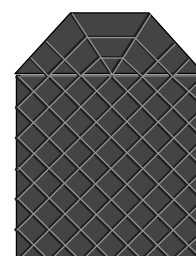
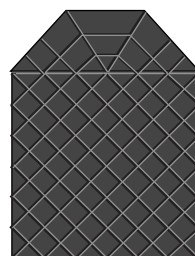
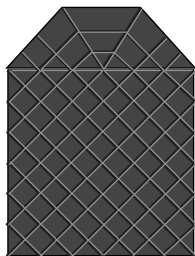
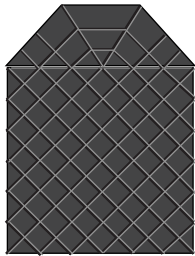
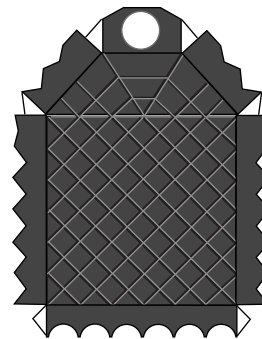
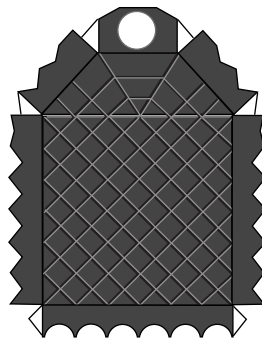
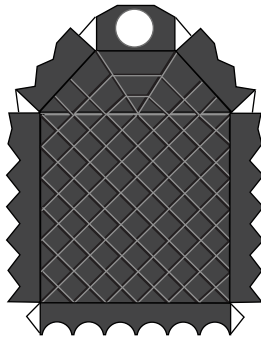
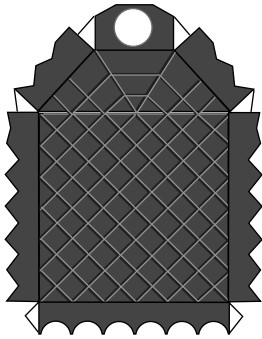



B10 Grid Fins

Print on Cardstock (110 lbs)

Back Print

1:100 Scale





1 cm

1 inch

1:100 Scale

SuperHeavy B10 Grid Fins

Print on Cardstock (110 lbs)

Detailed version

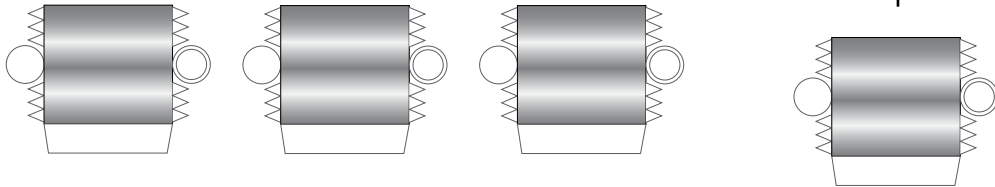
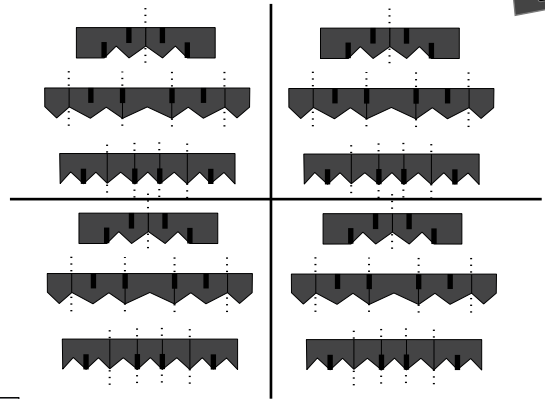
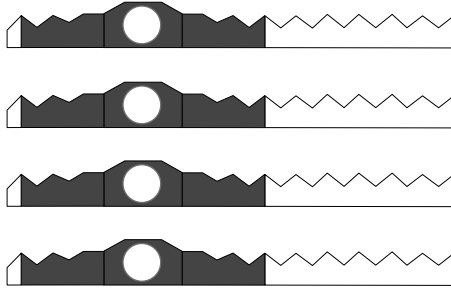
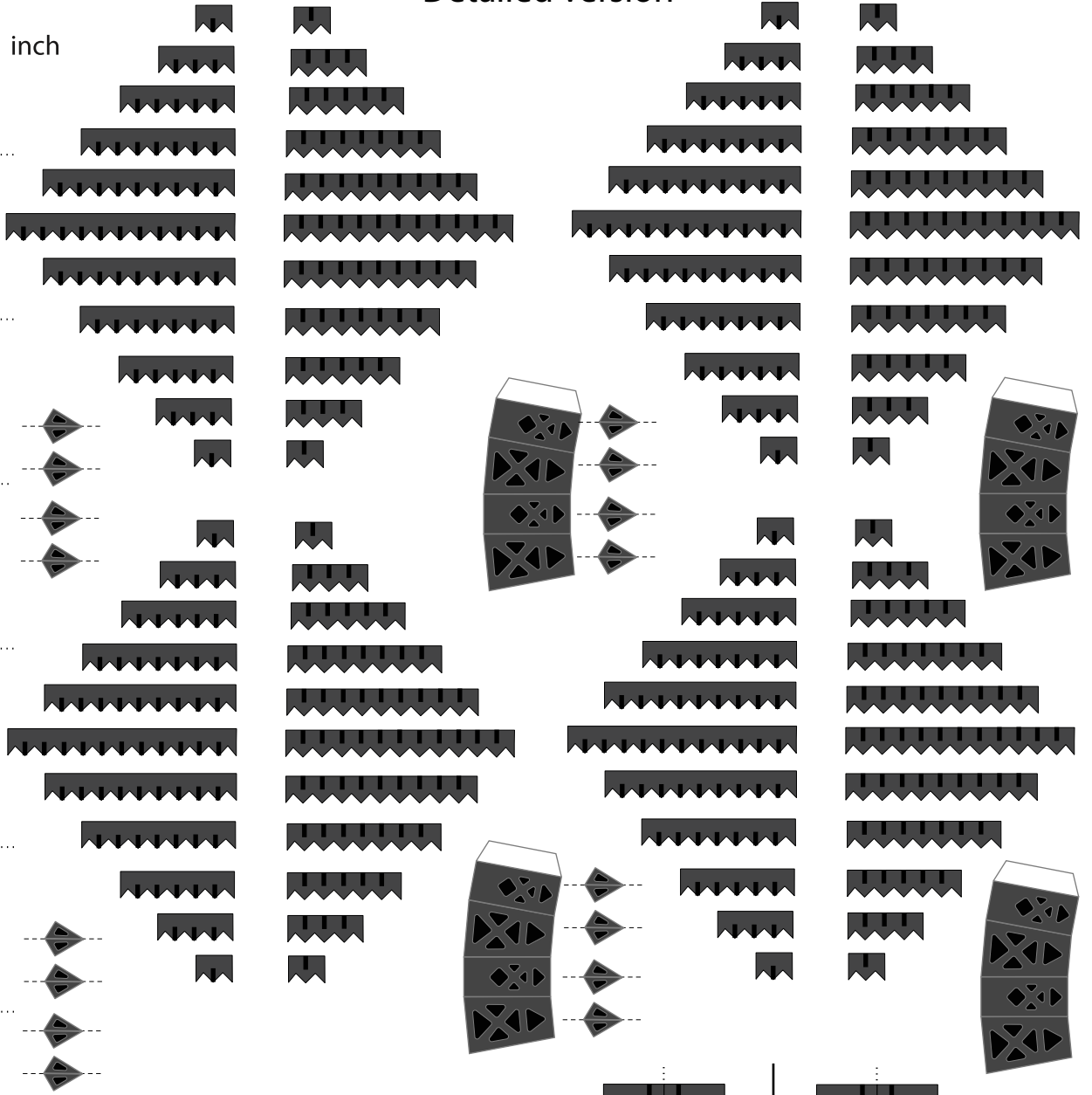
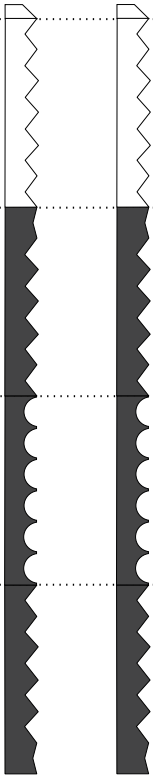



B10 Grid Fins back print

Print on Cardstock (110 lbs)

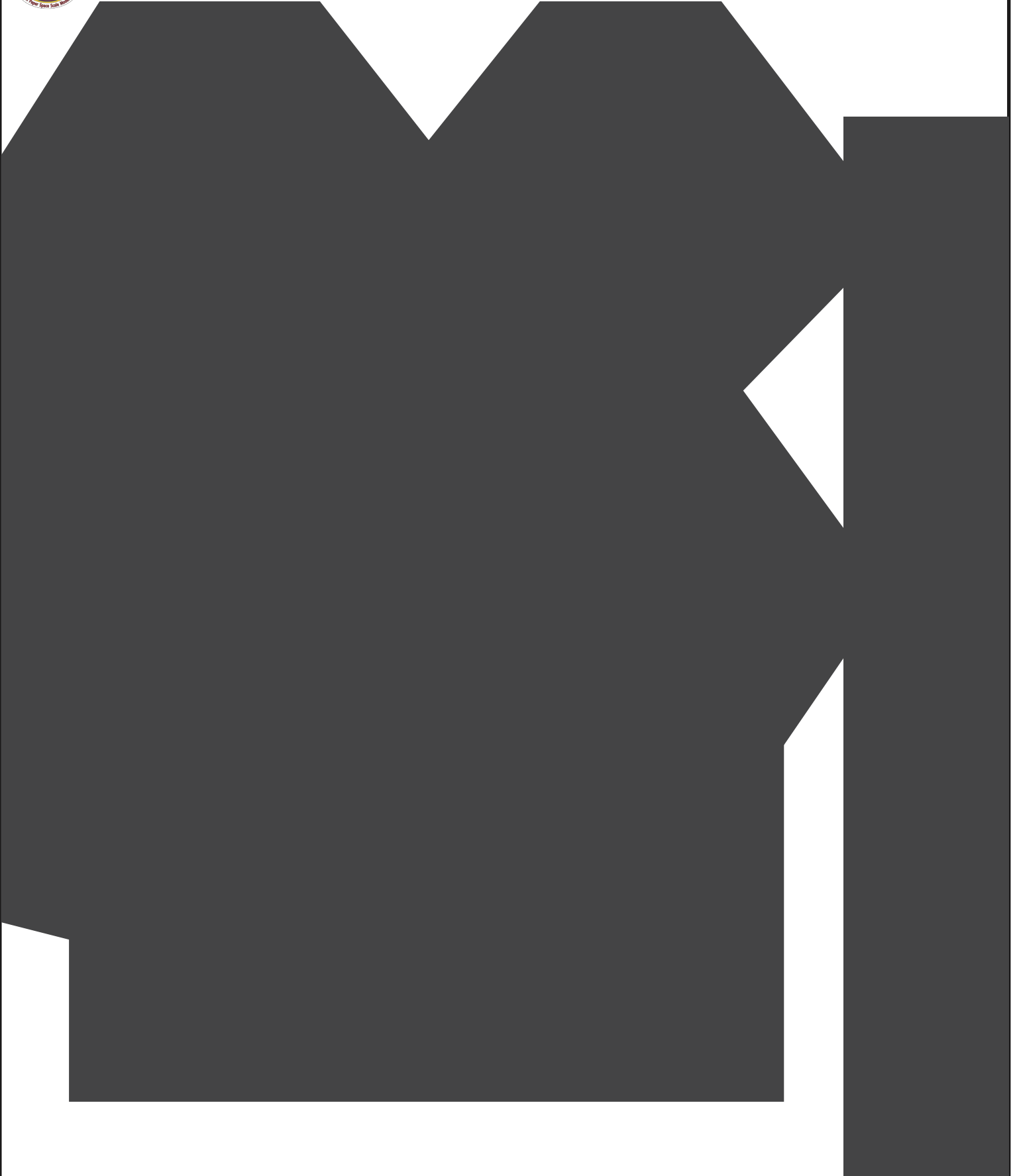



1:100 Scale



Booster 10

Print on Cardstock (110 lbs)

Belly side top

Revised

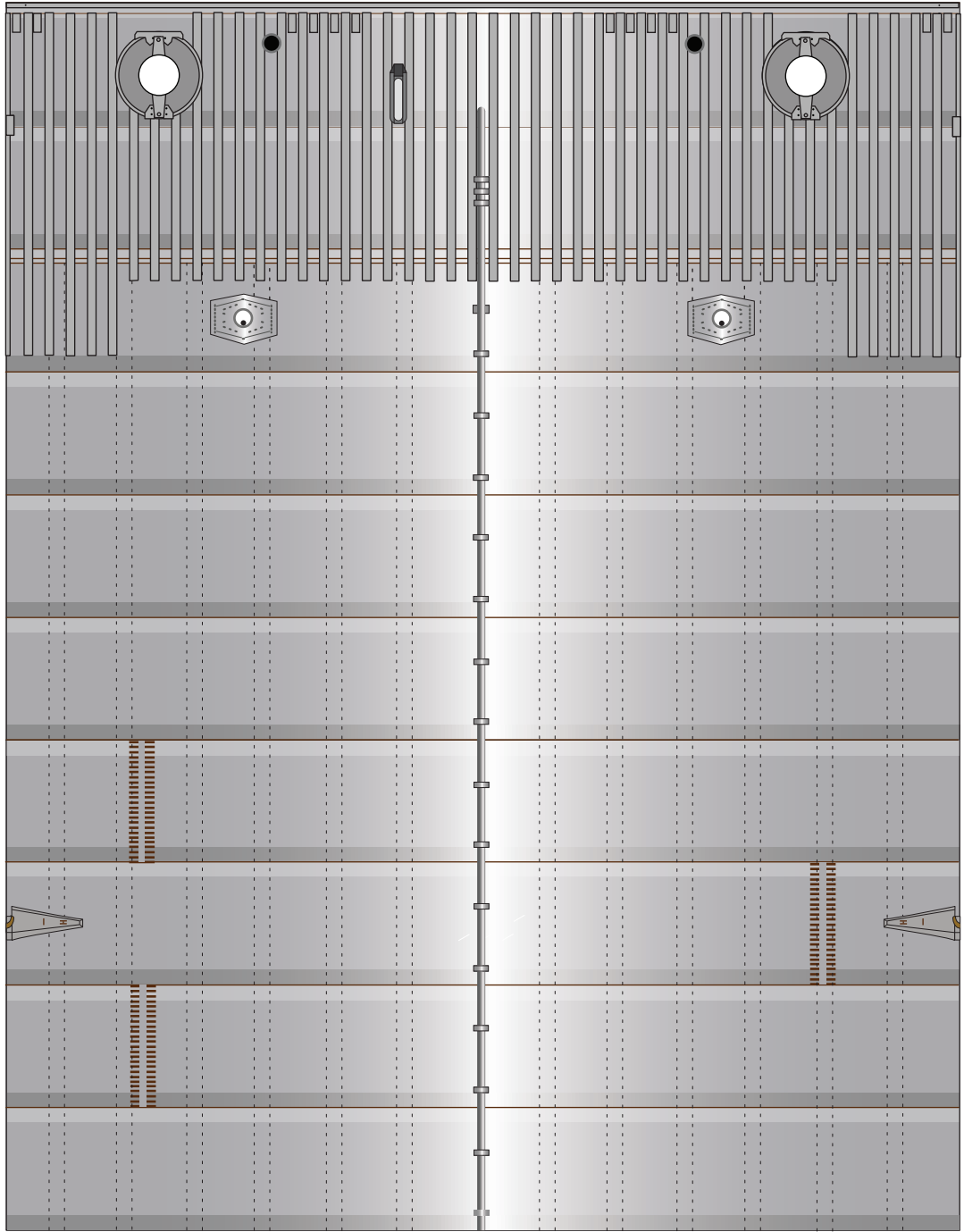
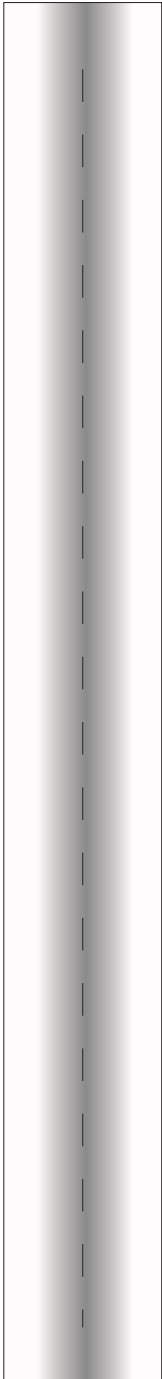
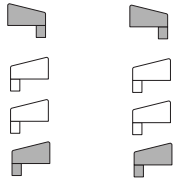



1:100 Scale



Booster 10

Print on Cardstock (110 lbs)

Back side top

Revised

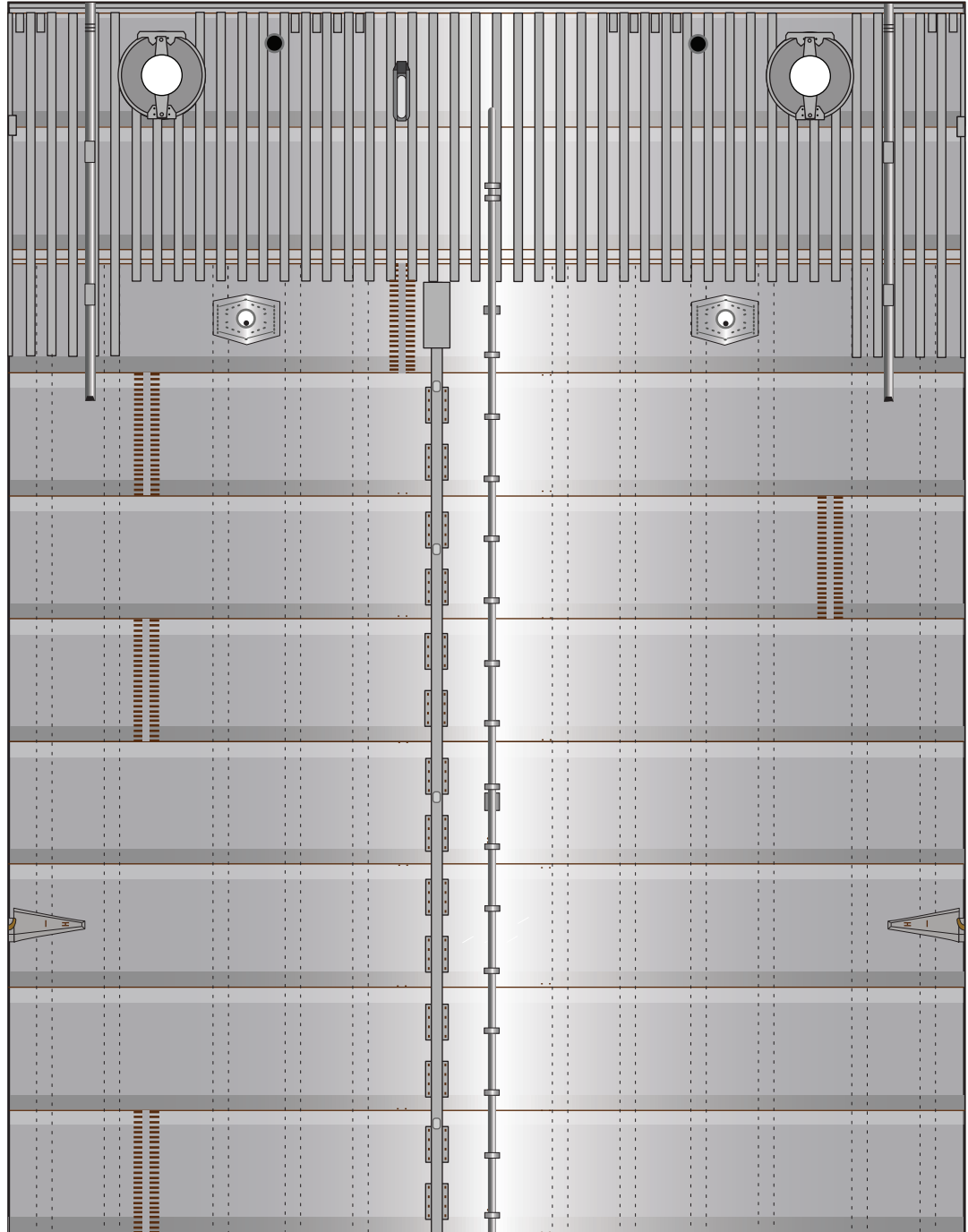
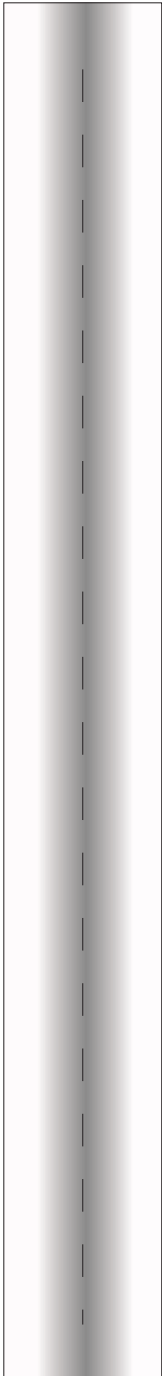



1:100 Scale

Booster 10

Print on Cardstock (110 lbs)

Belly side middle

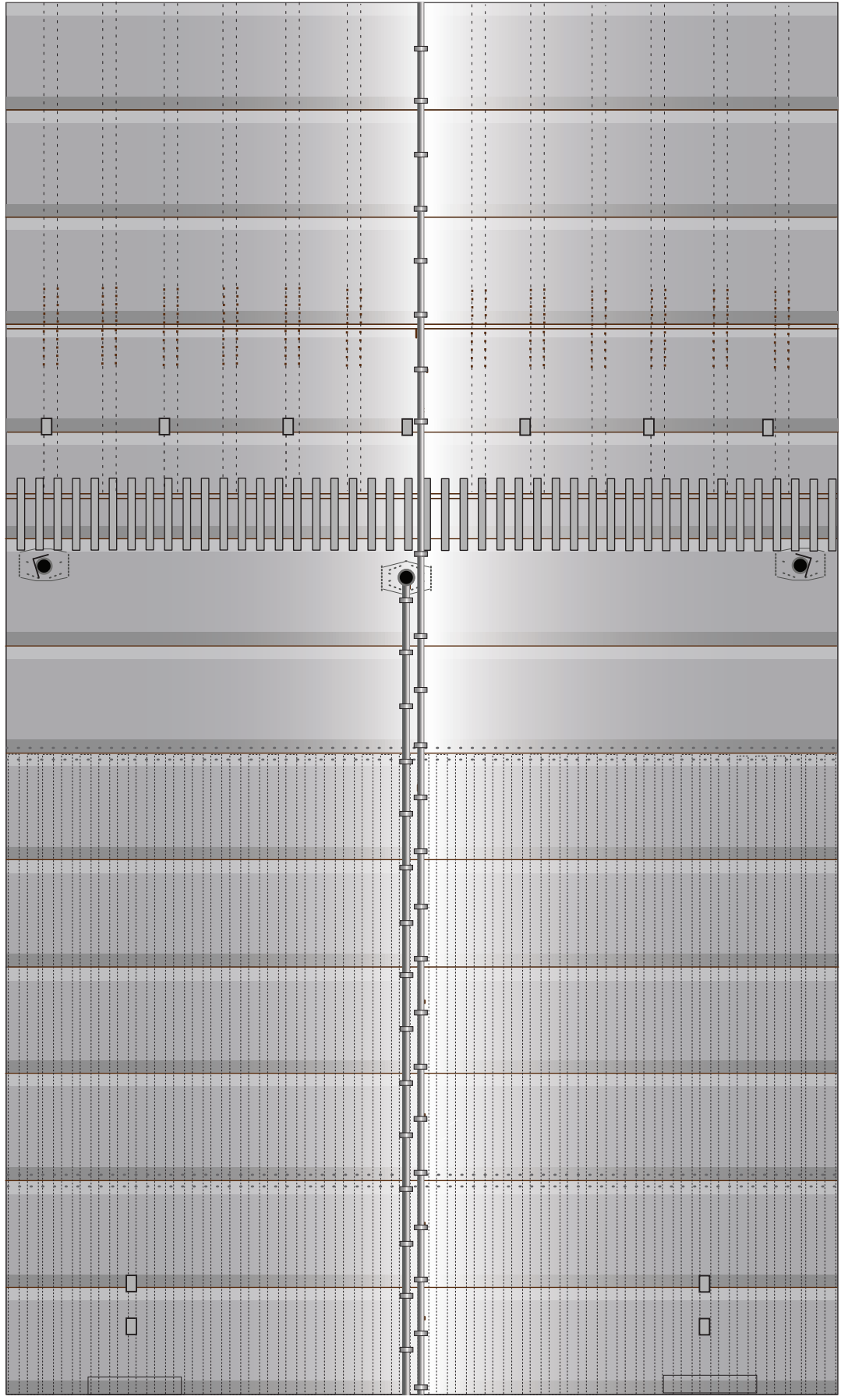
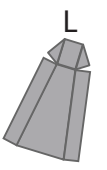
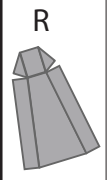



1:100 Scale

Booster 10

Print on Cardstock (110 lbs)
Back side middle

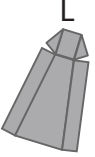
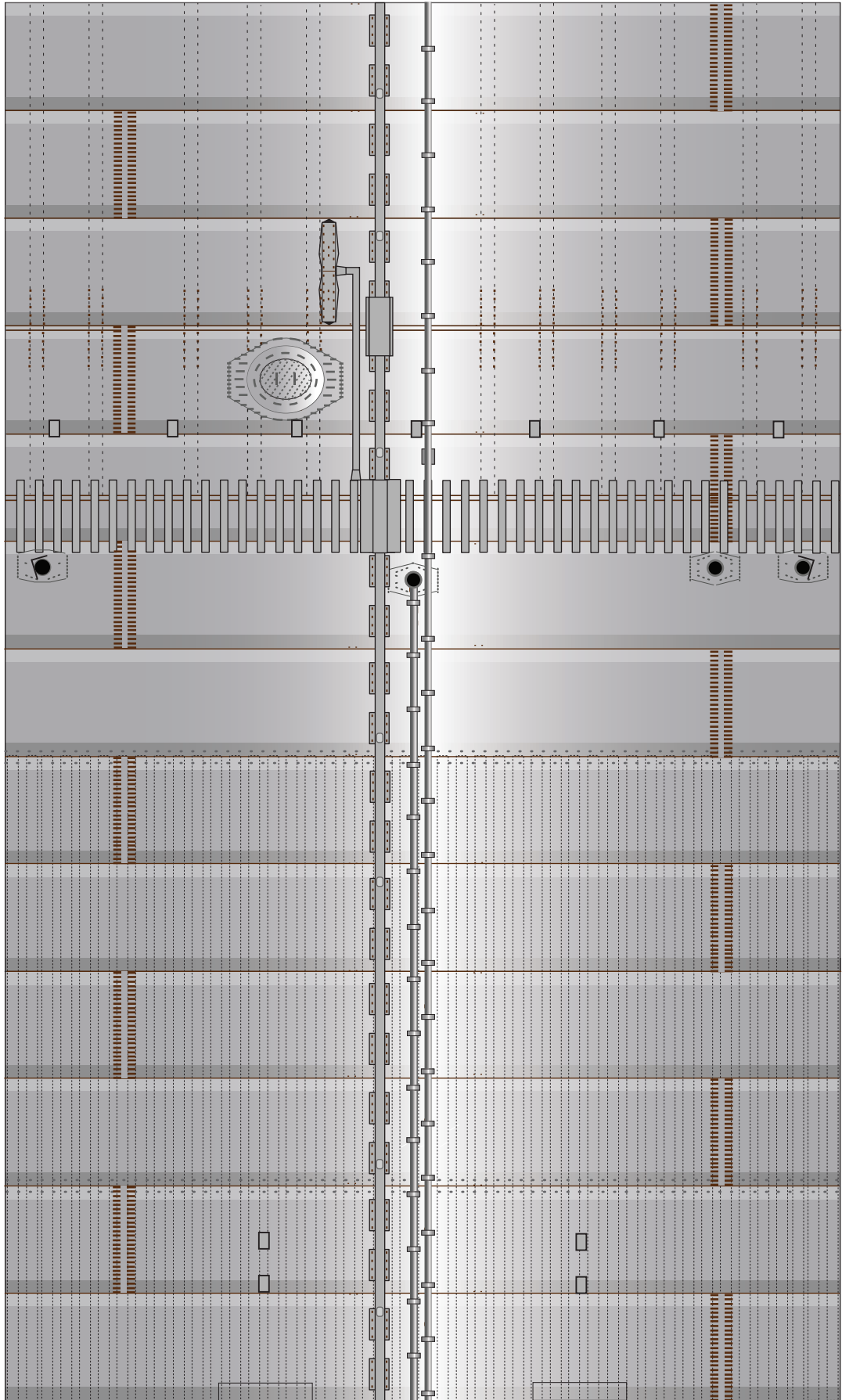
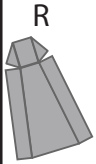



1:100 Scale

Booster 10

Print on Cardstock (110 lbs)

Belly side bottom

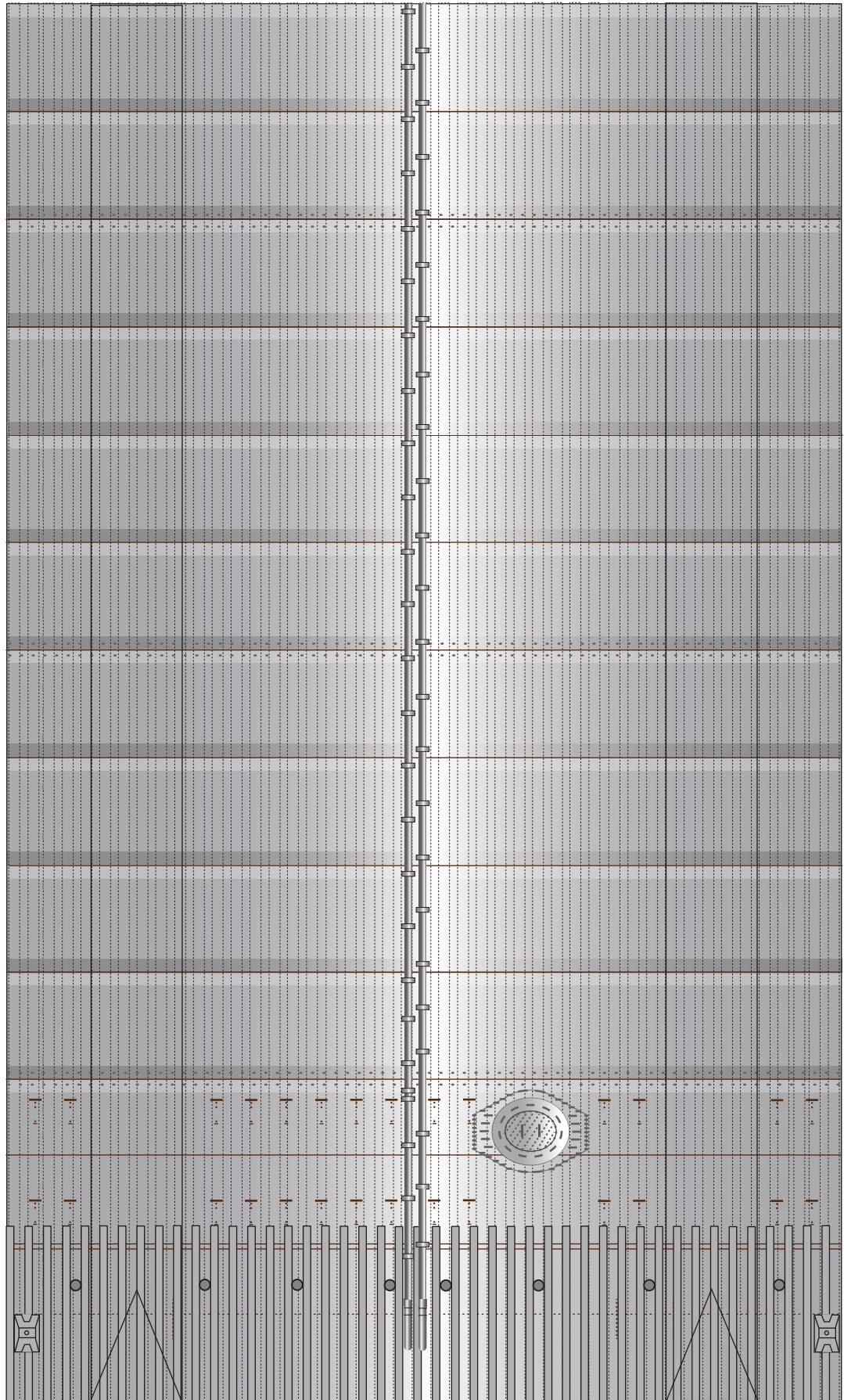
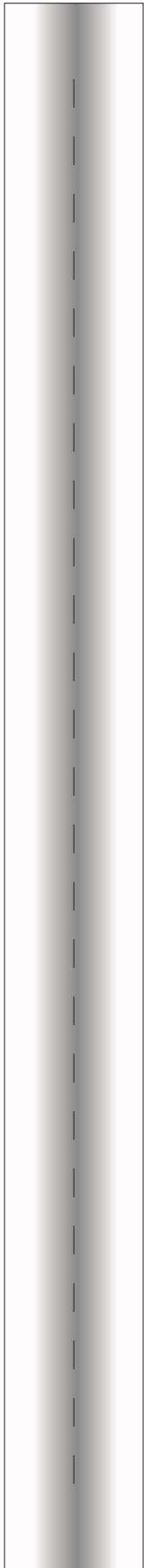



1:100 Scale

Revised

Booster 10

Print on Cardstock (110 lbs)
Back side bottom

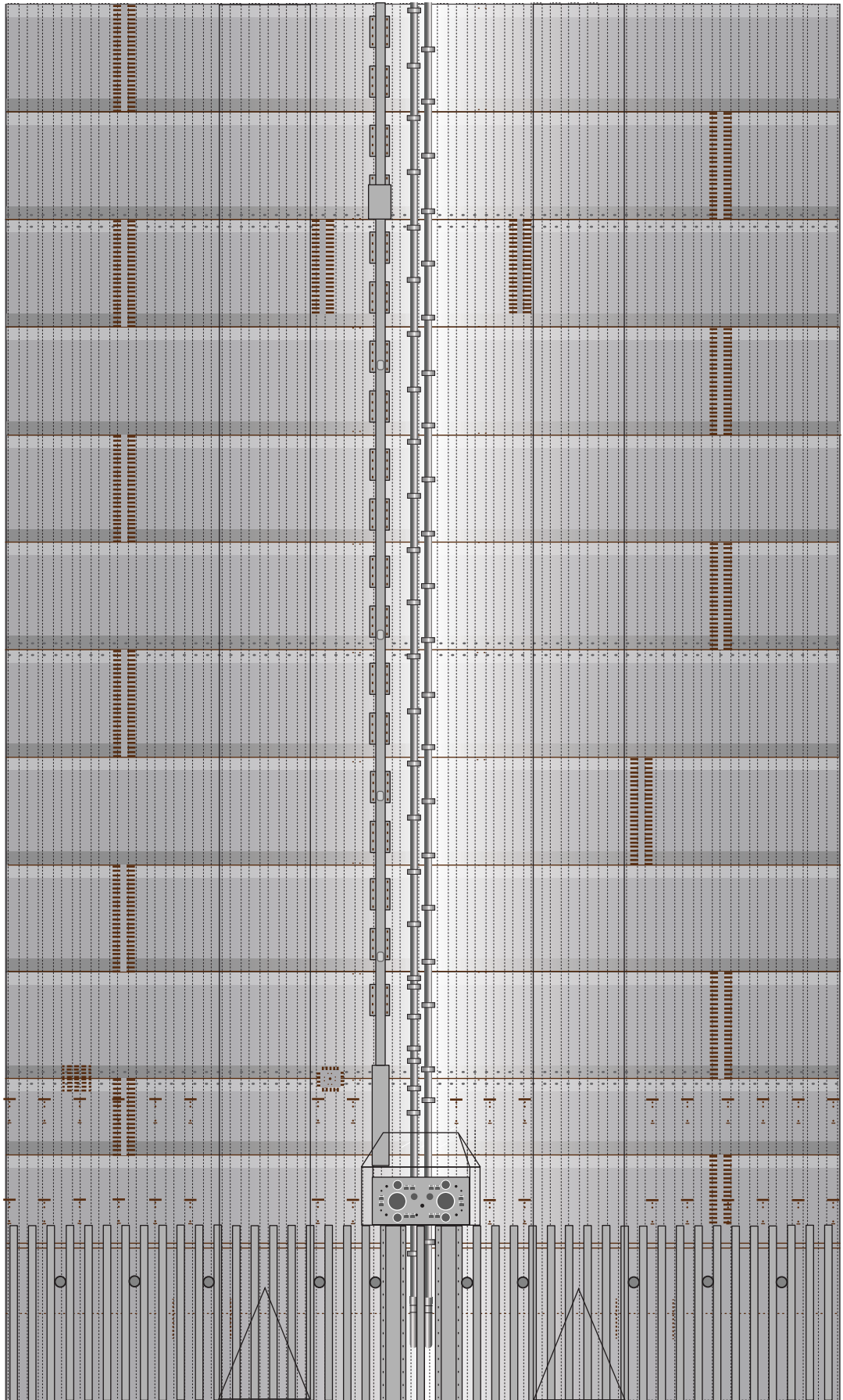
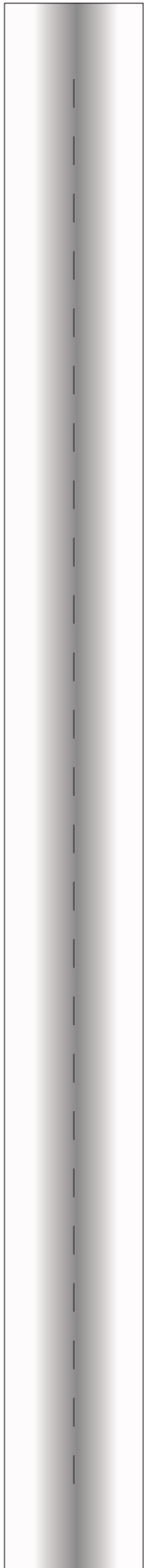



1:100 Scale



SpaceX Heavy booster 10

Print on cardstock (110 lbs)

COPV covers

FRONT

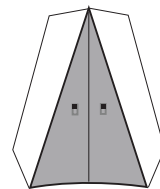
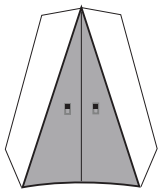
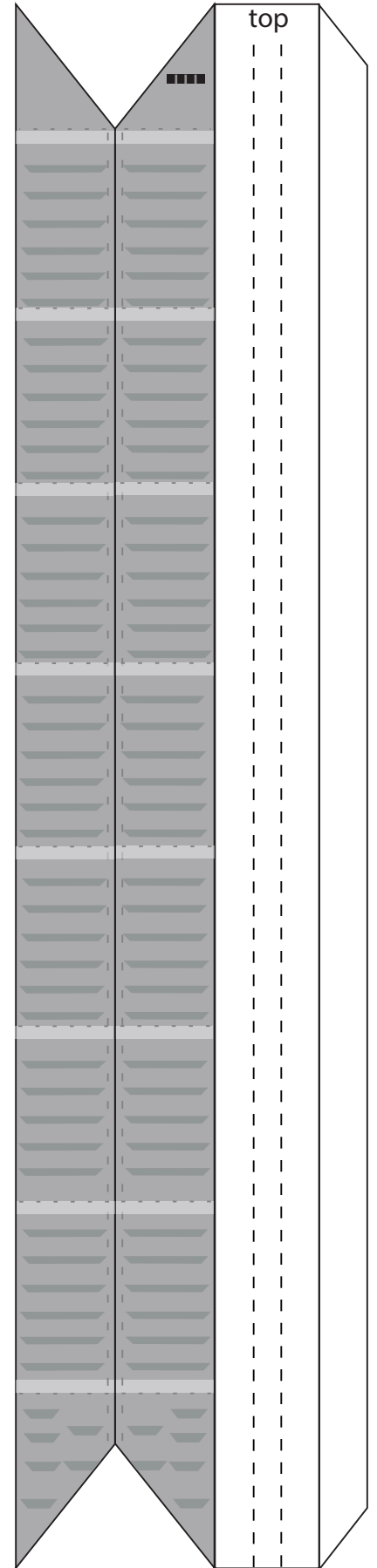
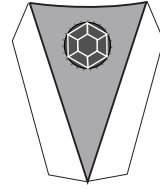
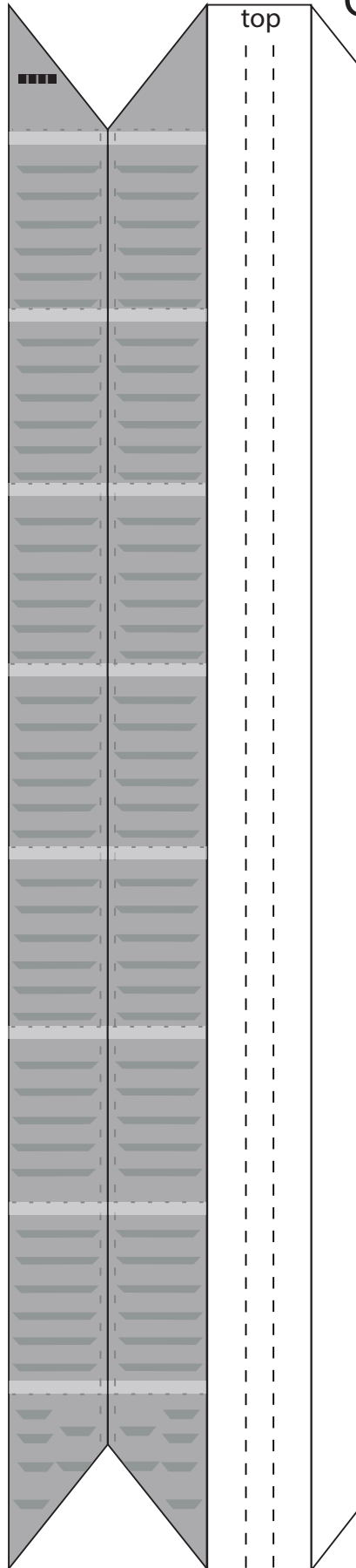
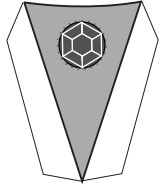



1:100 Scale



SpaceX Heavy booster 10

Print on cardstock (110 lbs)

COPV covers

Umbilical side

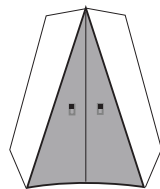
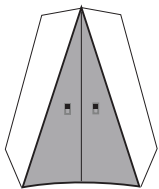
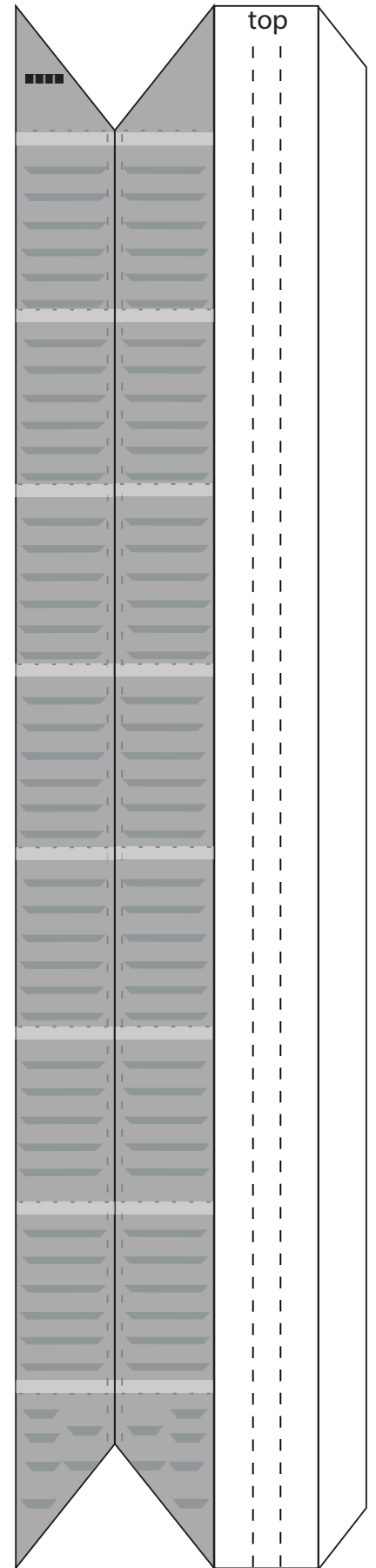
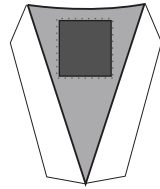
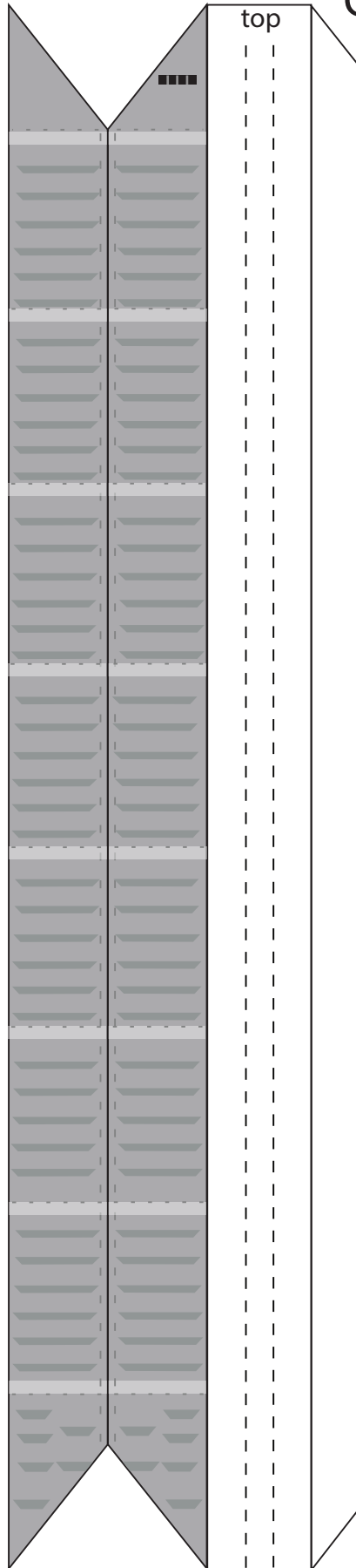
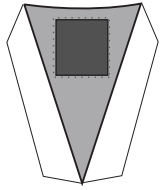



1:100 Scale



SpaceX Starship B10

Formers for top section

Print on Cardstock (110 lbs)

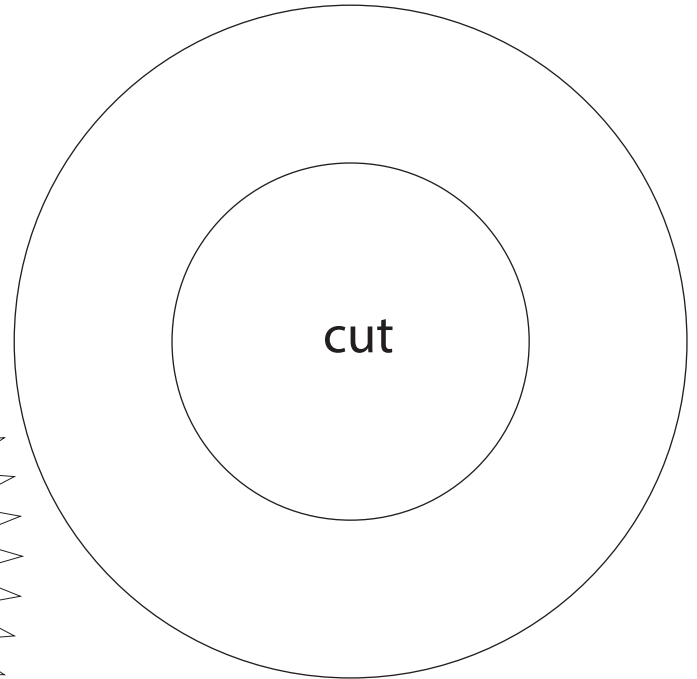
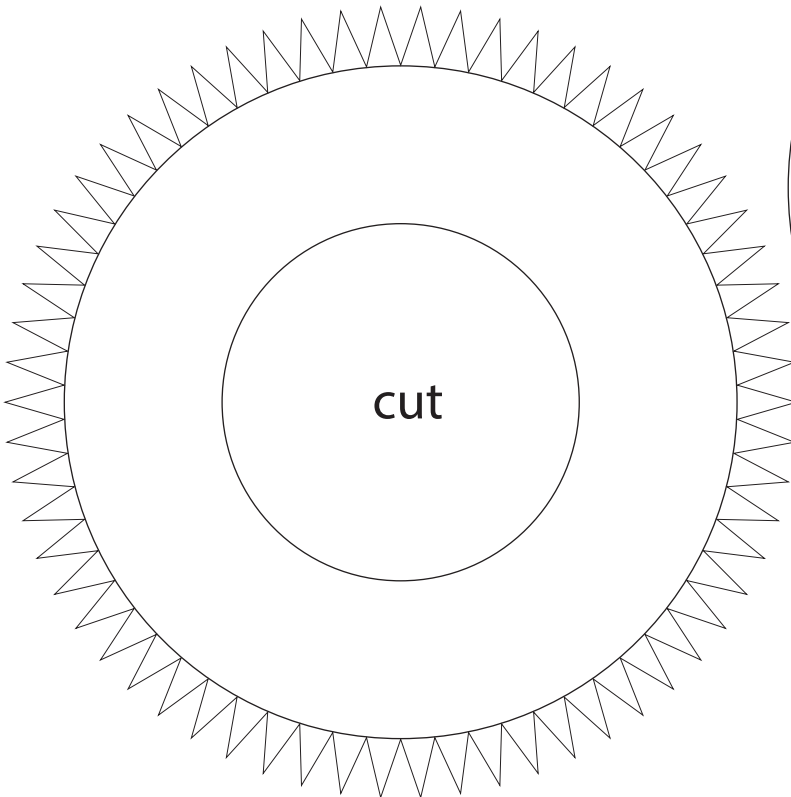
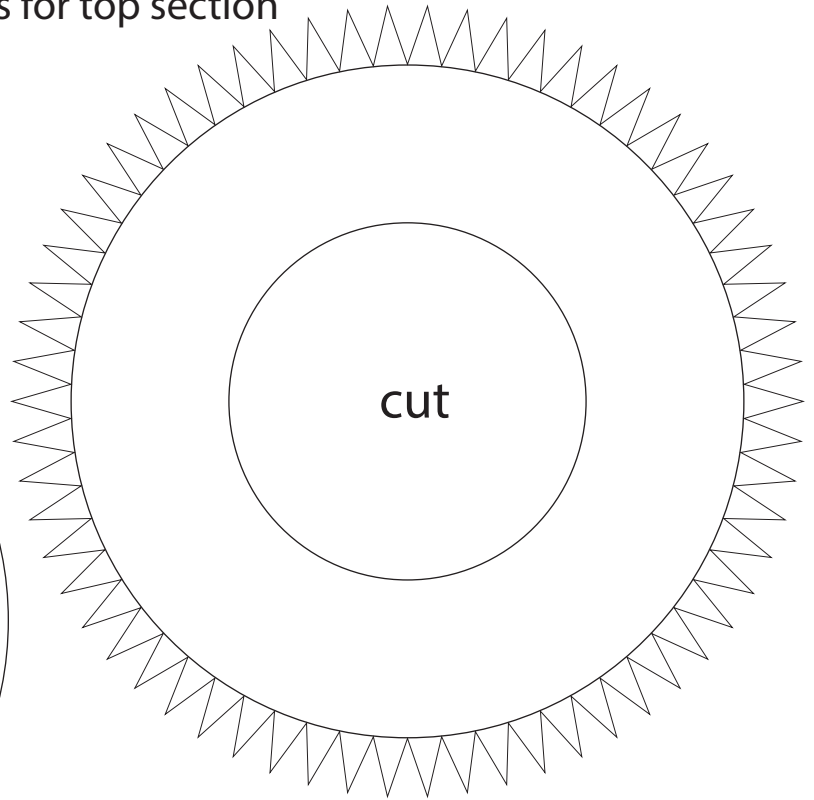
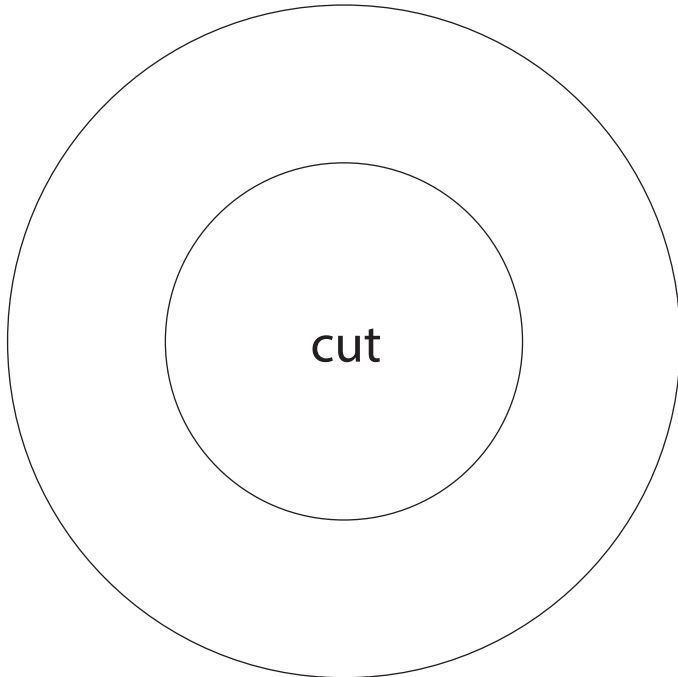

IMPORTANT
Top former is glued 42 mm from top edge of top booster section.
Bottom former is glued 20 mm from bottom edge of top booster section.



1:100 Scale



SpaceX Starship B10

Print on Cardstock (110 lbs)

Formers for middle body

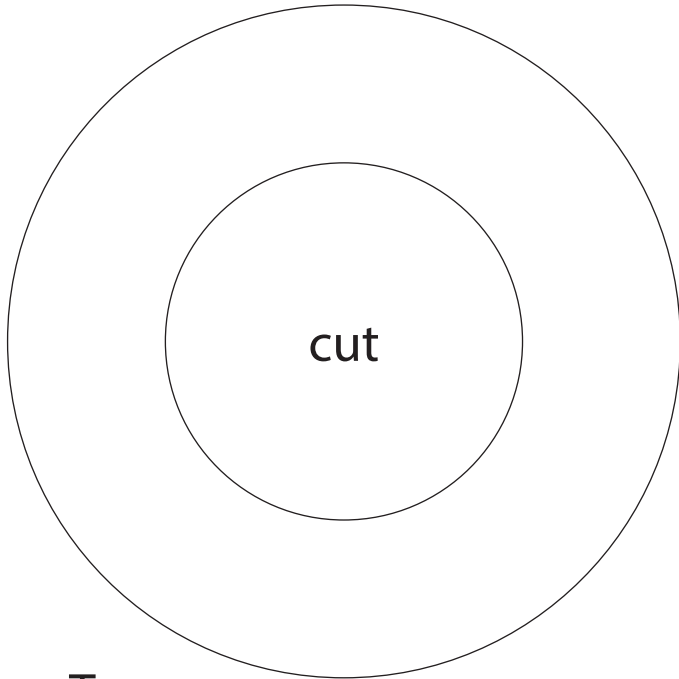

Top

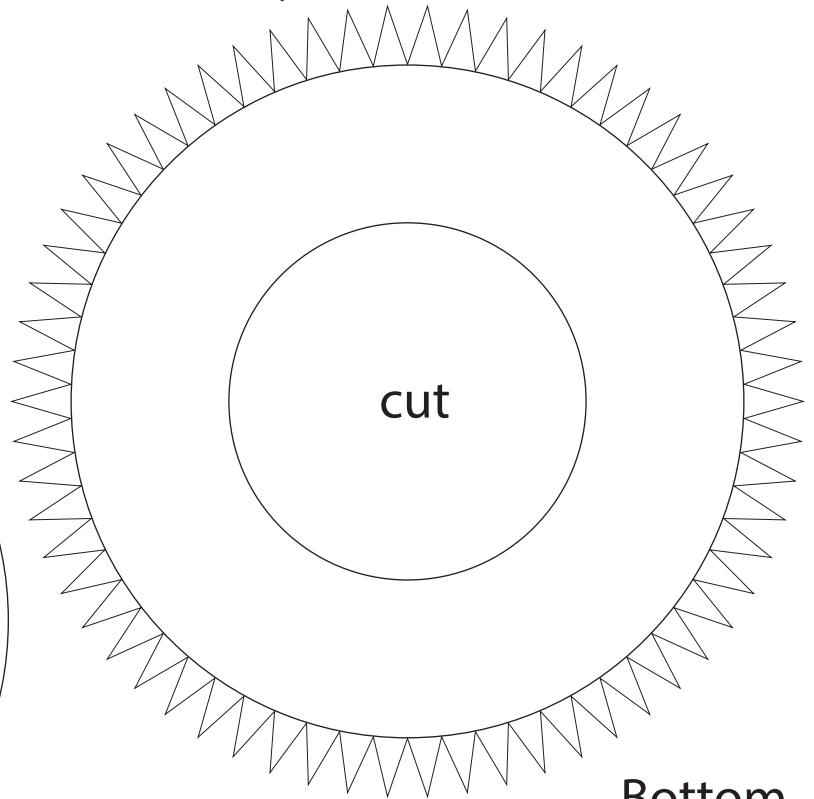

Bottom

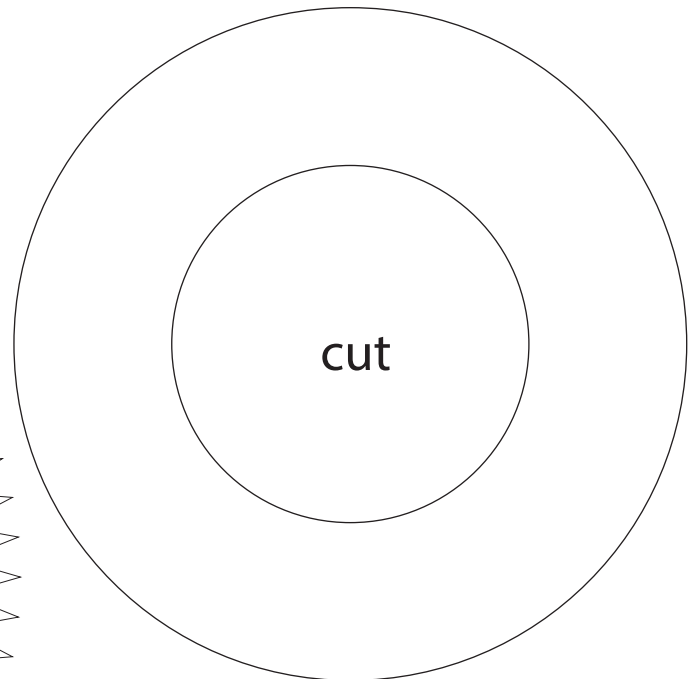
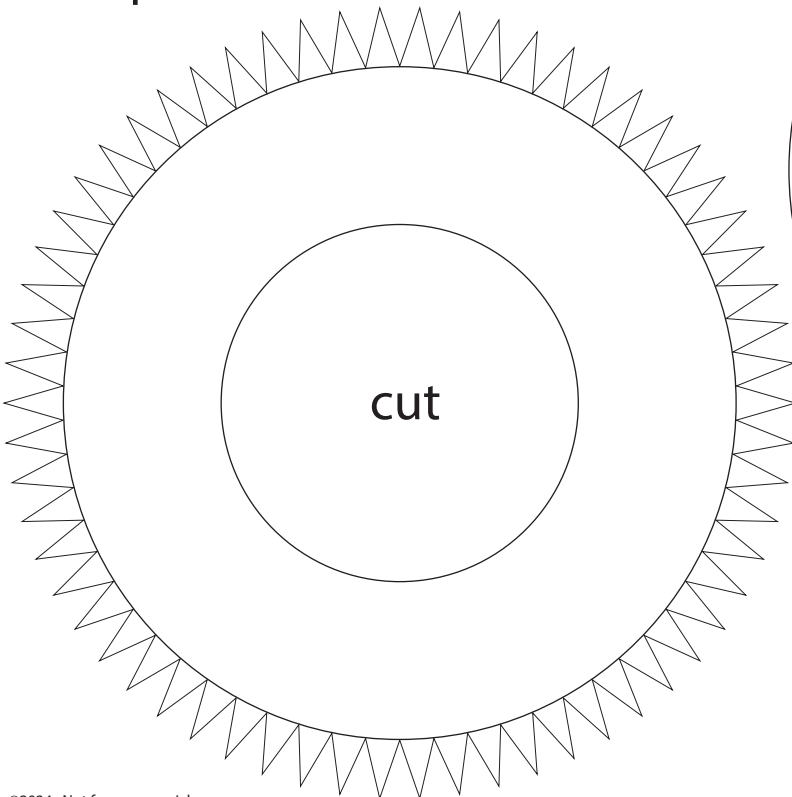

IMPORTANT

Top former is glued 20 mm from top edge of middle booster section. Bottom former is glued 20 mm from bottom edge of middle booster section.



1:100 Scale

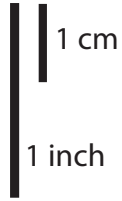

SpaceX Starship B10

Print on Cardstock (110 lbs)

Formers for bottom body

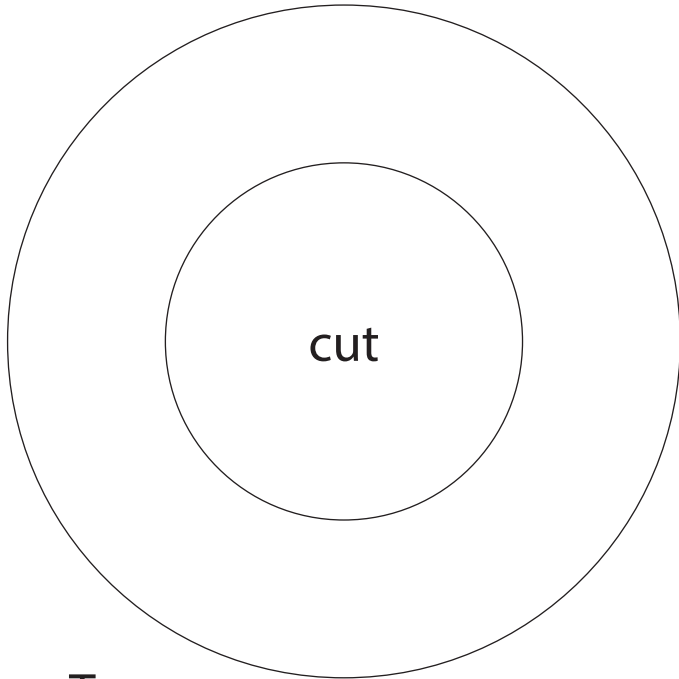

Top

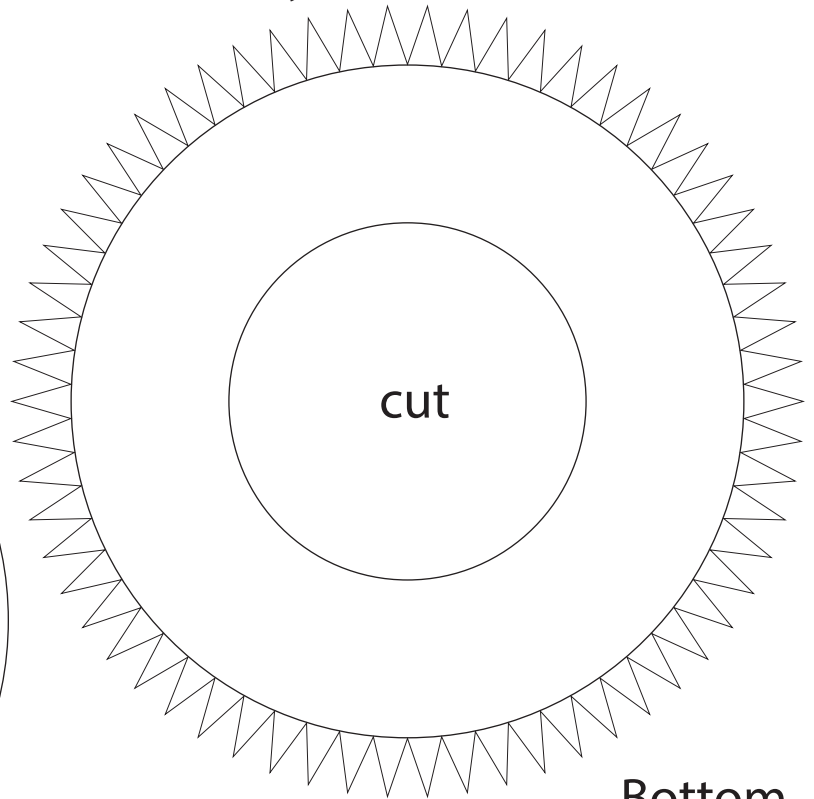

Bottom

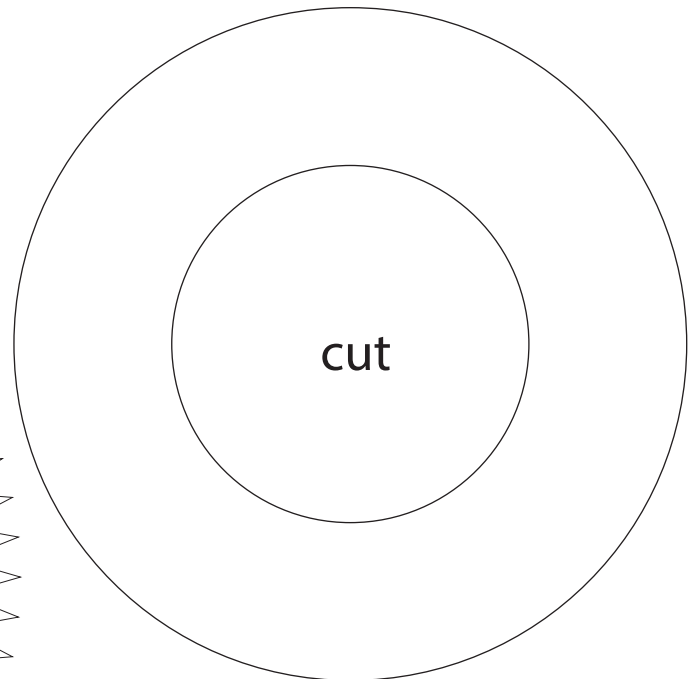
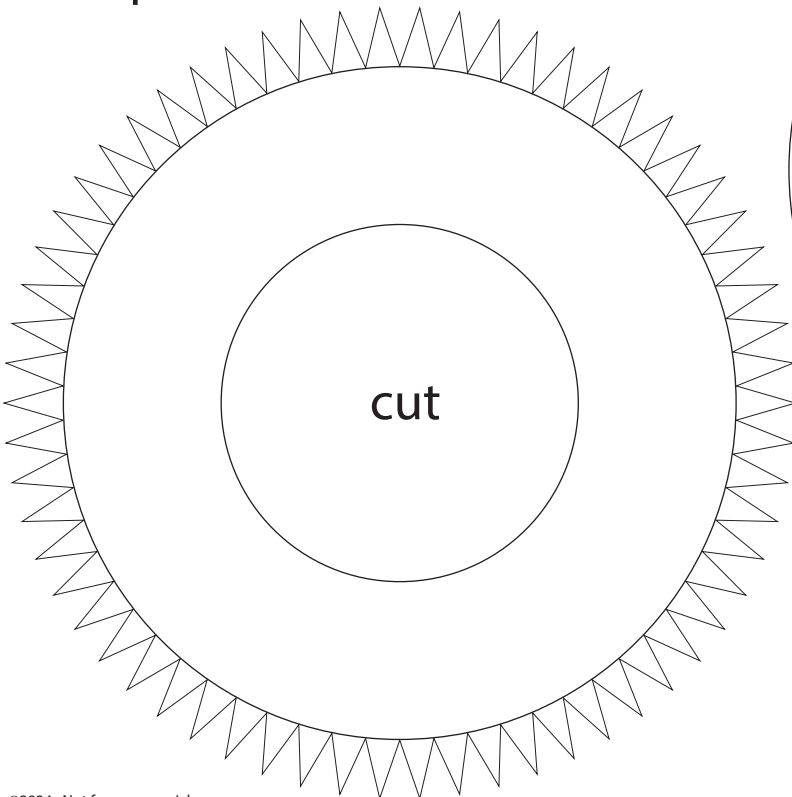

IMPORTANT

Top former is glued 20 mm from top edge of bottom booster section. Bottom former is glued 19 mm from bottom edge of bottom booster section.



1 cm

1 inch

1:100 Scale

SpaceX SuperHeavy

Print on Cardstock (110 lbs)

Outer Raptor ring

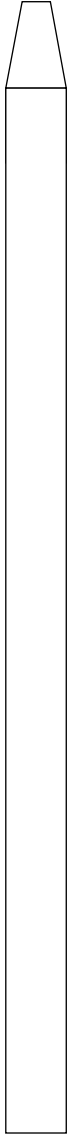
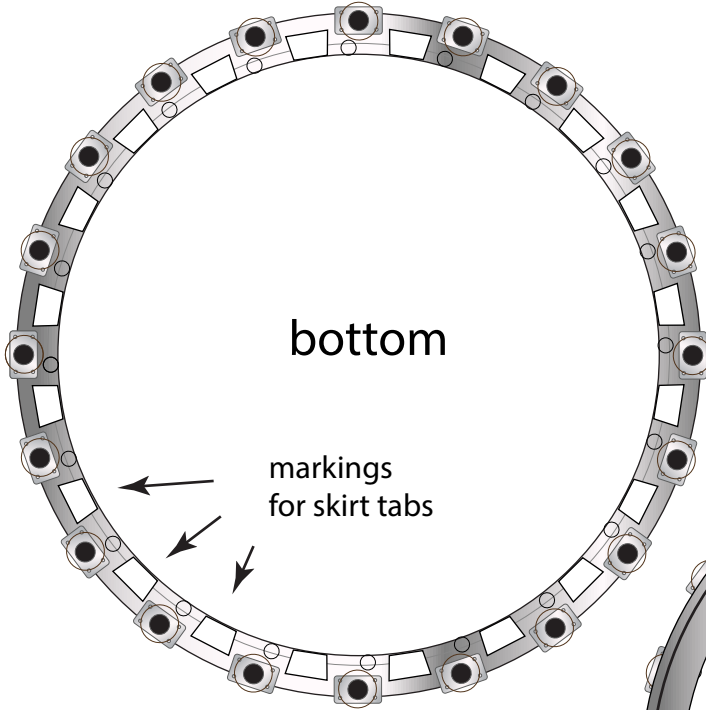

Engine section interior layer





1 cm

1 inch

1:100 Scale

SpaceX Heavy Booster 10

Print on Cardstock (90 lbs)

Skirt for engine section

Revised

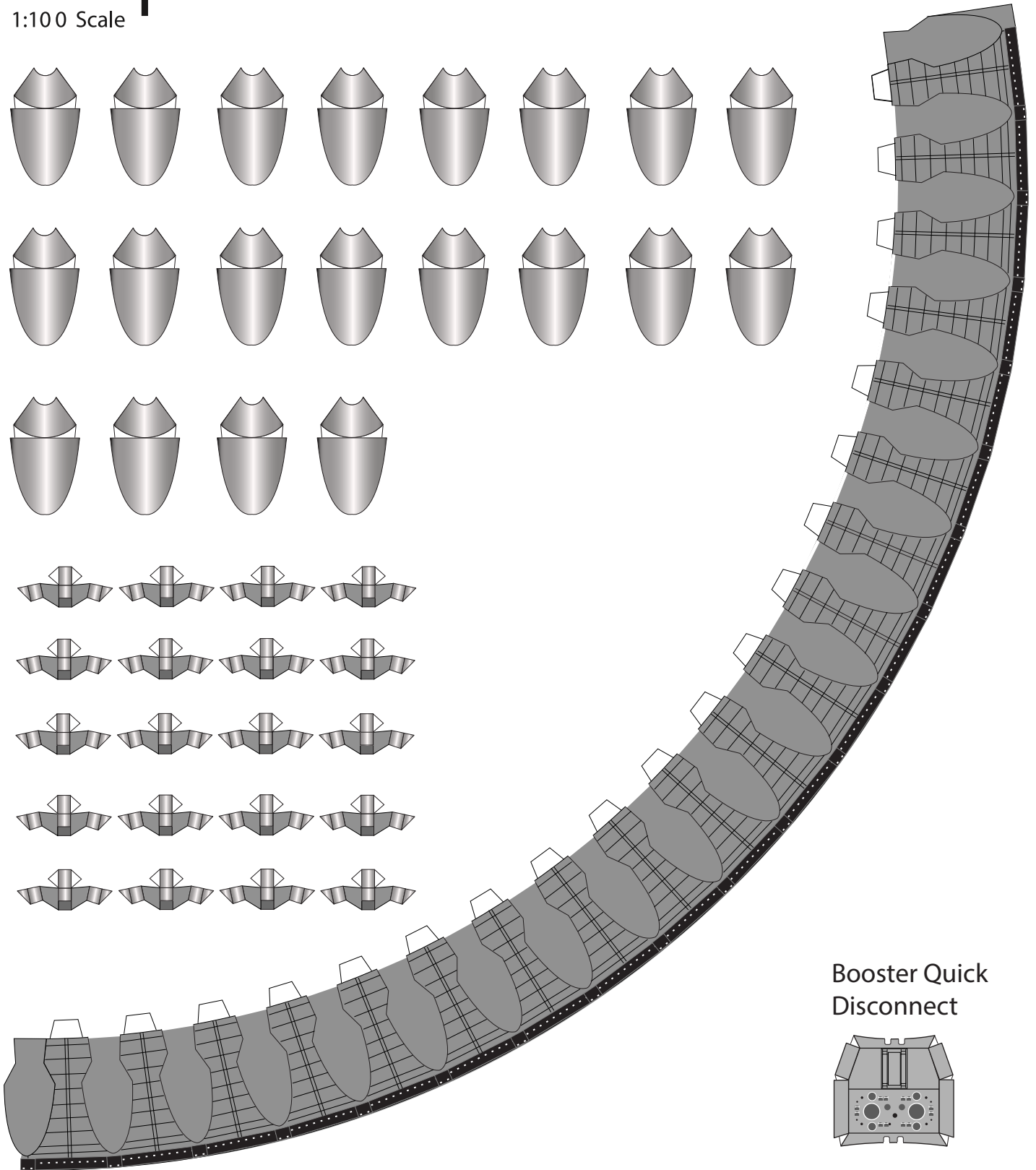
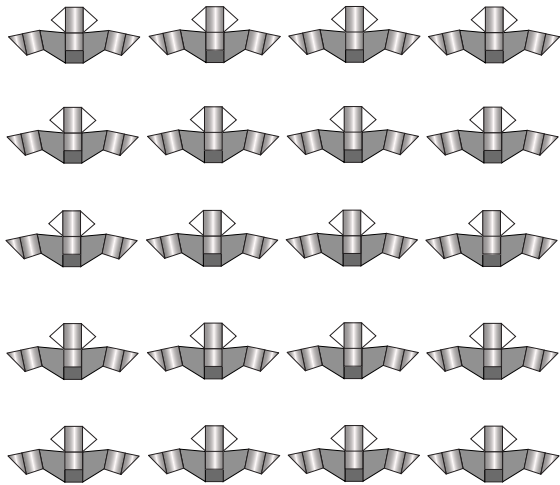
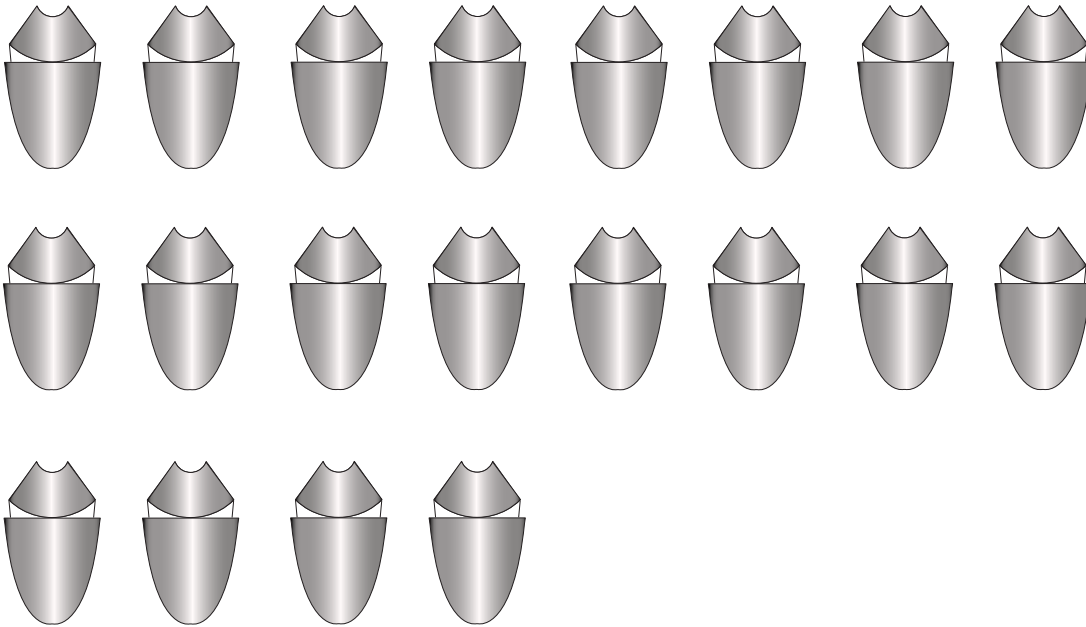

Booster Quick Disconnect

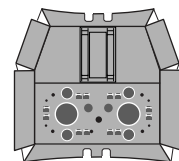

Place 2 magnets on the back to match with magnets from OLM's QD arm



1:100 Scale

SpaceX Heavy Booster 9

Skirt floor and wall

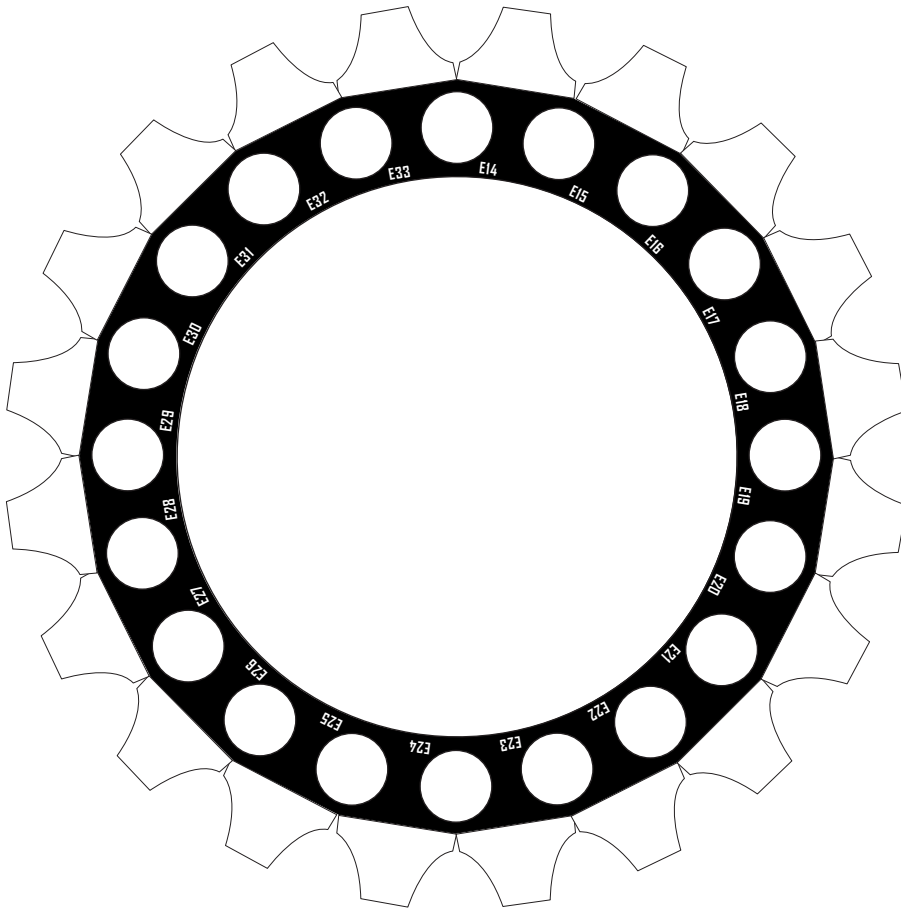

Glue Raptor base

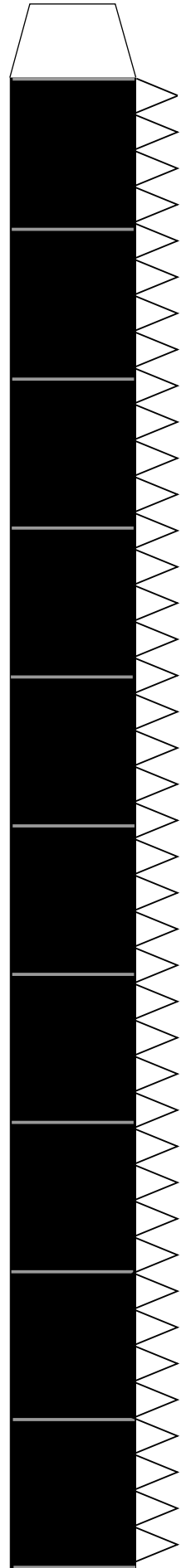
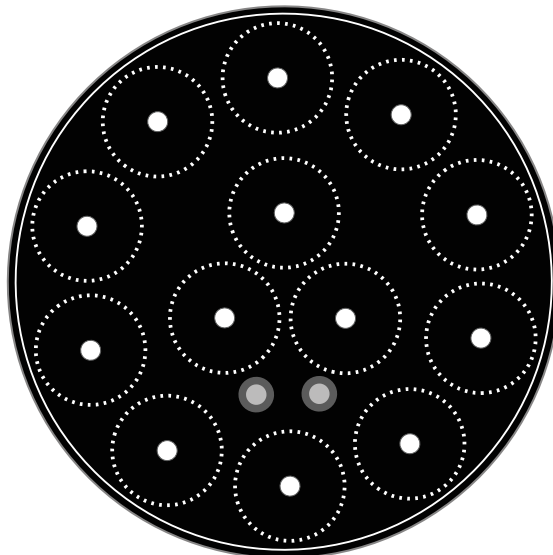

Print on Cardstock (90 lbs)



1 cm

1 inch

1:100 Scale

SpaceX Heavy Booster 10

Raptor location

Umbilical side

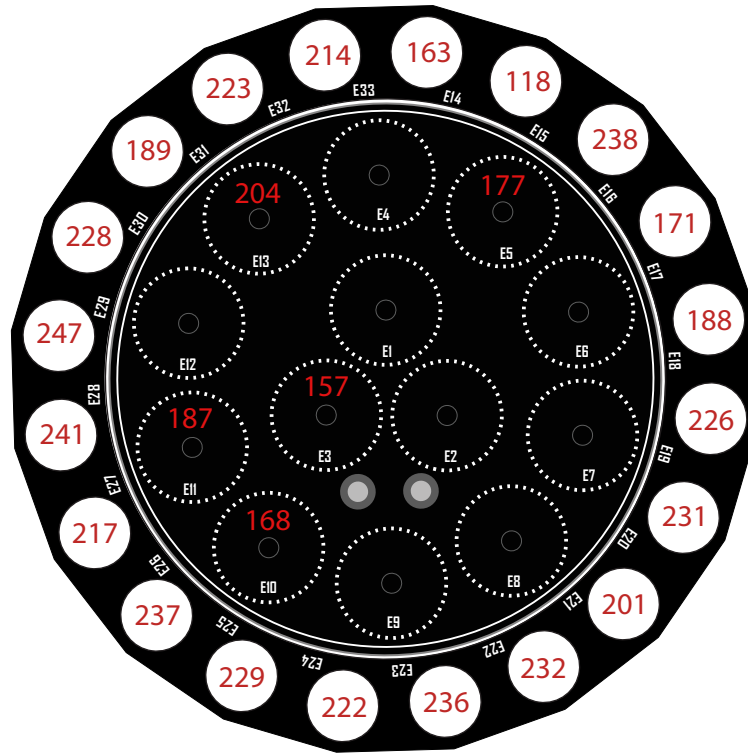

Reference data from Nick (Ring Watchers)



1 cm

1 inch

1:100 Scale

B10 inner Raptor covers

Print on cardstock

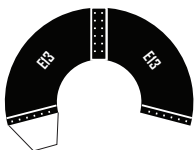
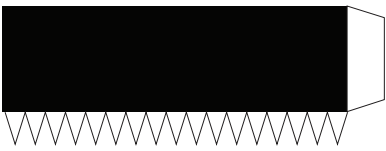
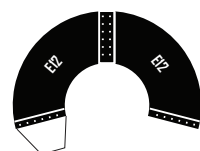
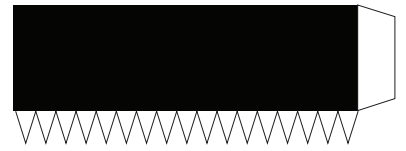
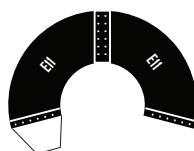
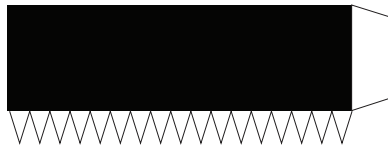
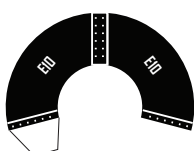
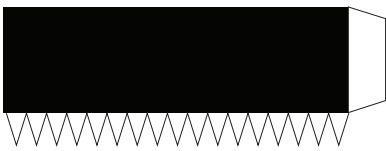
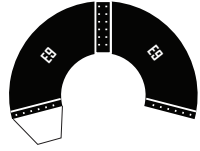
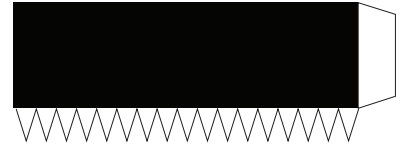
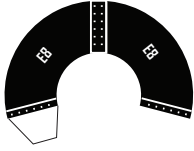
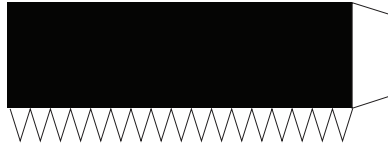
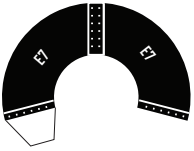
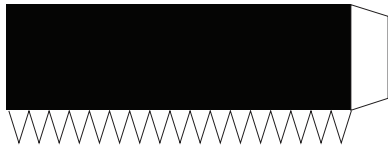
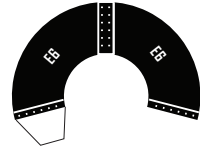
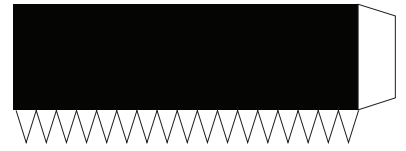
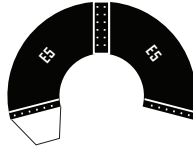
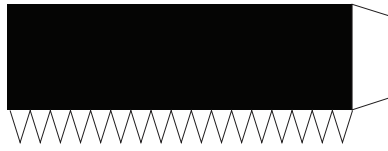
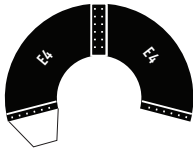
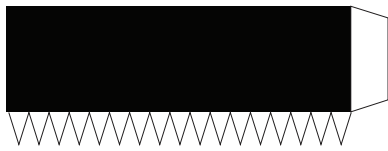
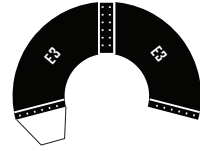
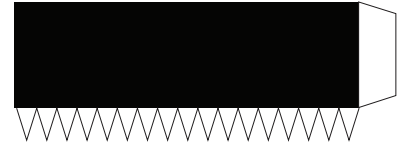
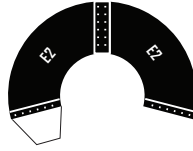
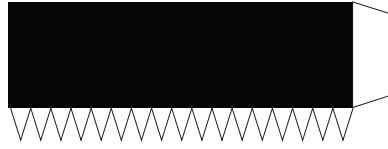
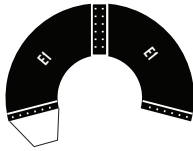
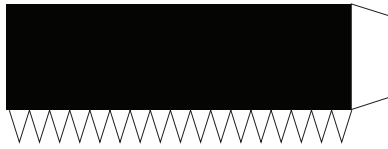



1 cm

1 inch

1:100 Scale

SuperHeavy Raptors

Print on Cardstock (110 lbs)

B10





SuperHeavy Raptors BACKPRINT

Print on Cardstock (110 lbs)

