

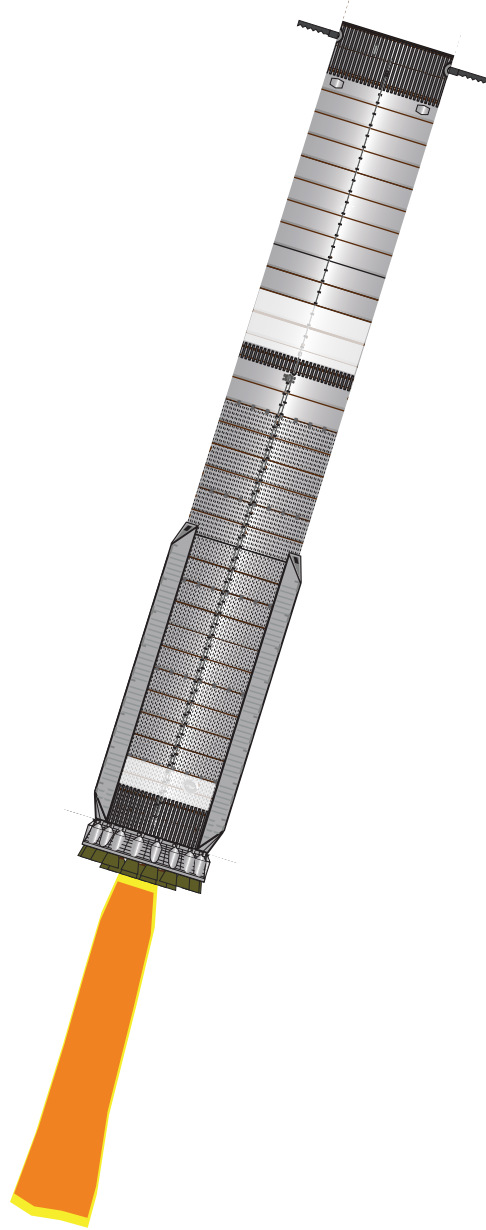

First catch by tower

B12

1:100 Scale

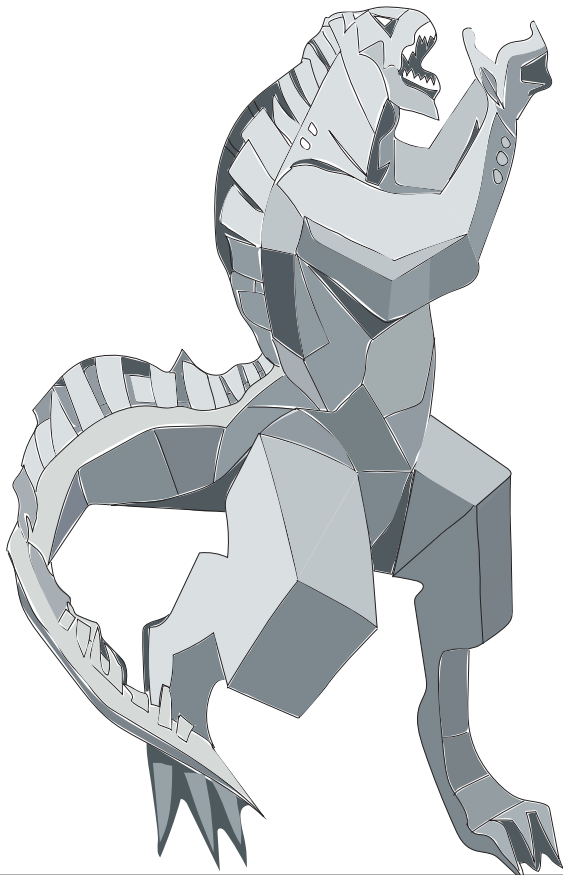

Designed by Alfonso X Moreno

©2024 Not for commercial use



SpaceX SuperHeavy

Print on Cardstock (110 lbs)

1:100 Scale

Top ring

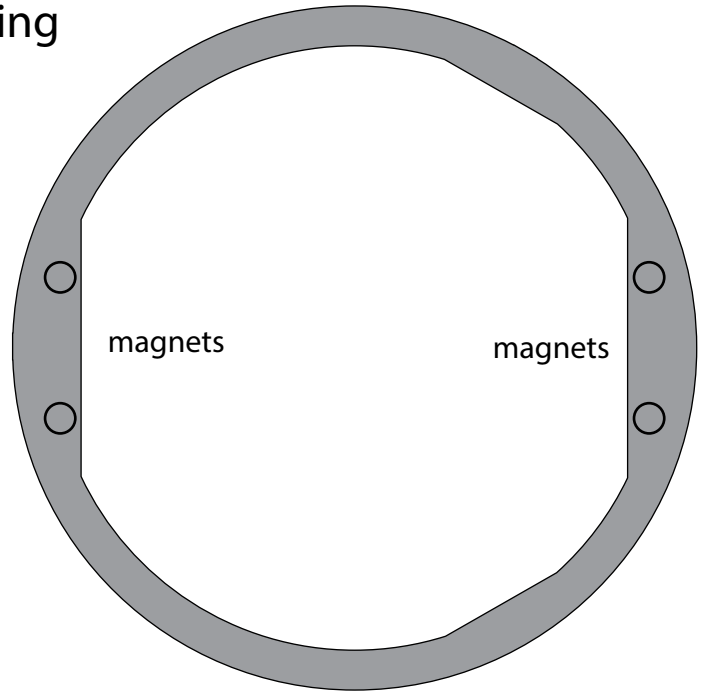
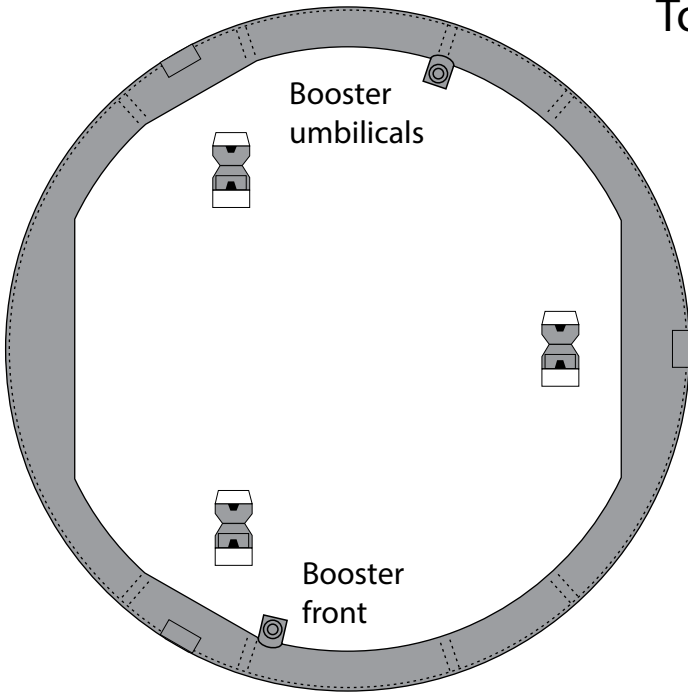

Bottom ring

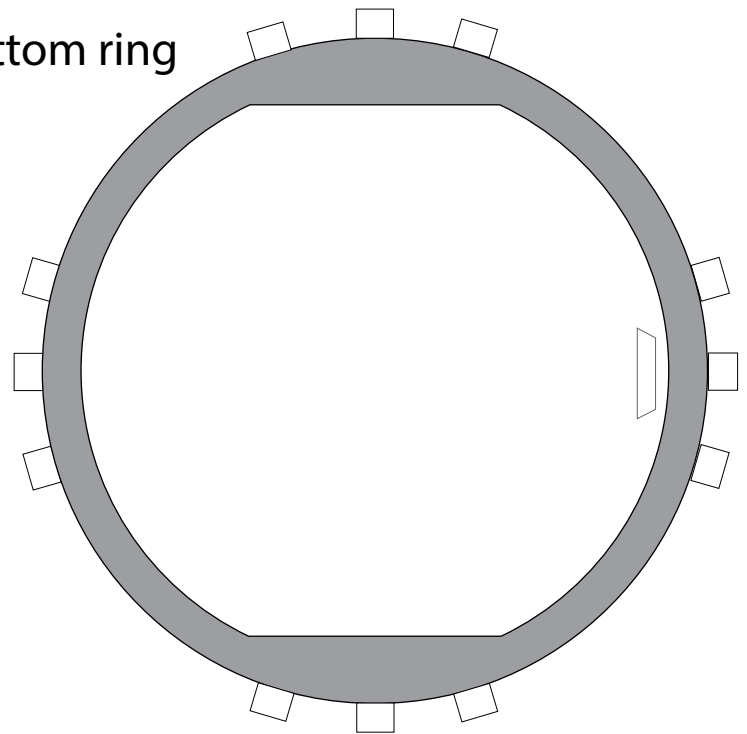
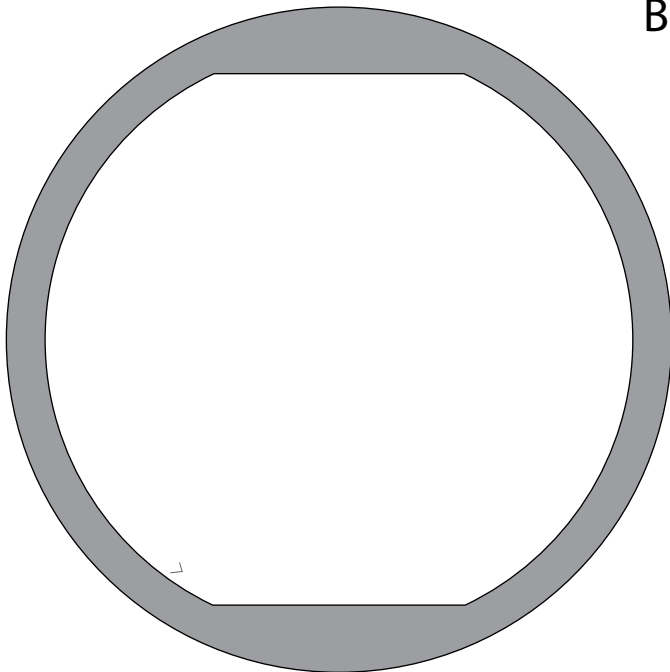



1 cm

1 inch

1:100 Scale

SuperHeavy B12 Upper Dome

Print on Cardstock (110 lbs)

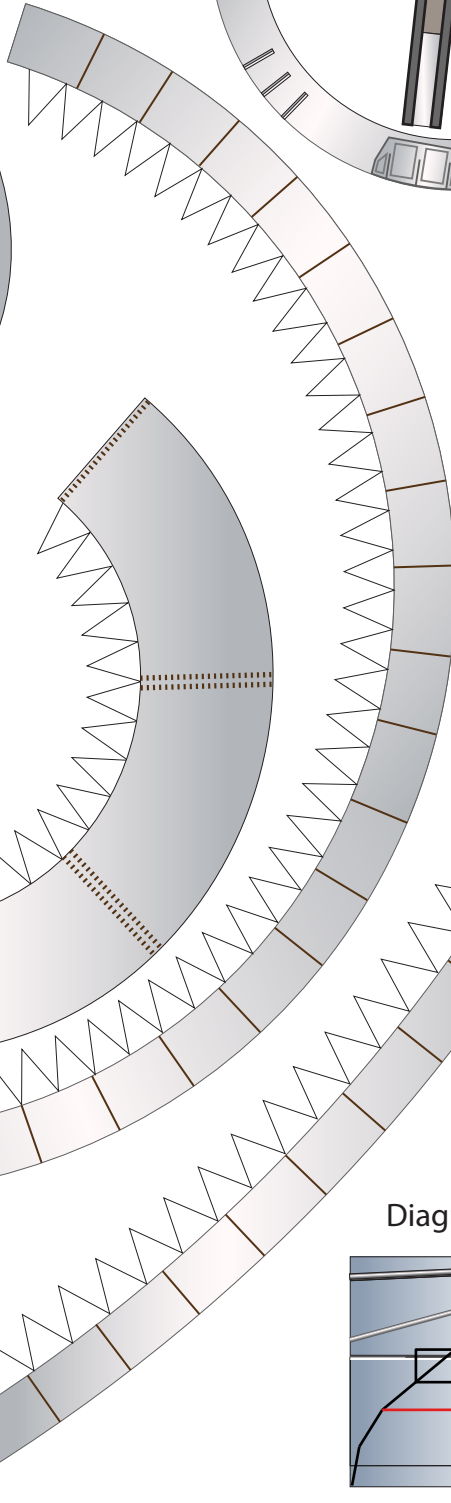
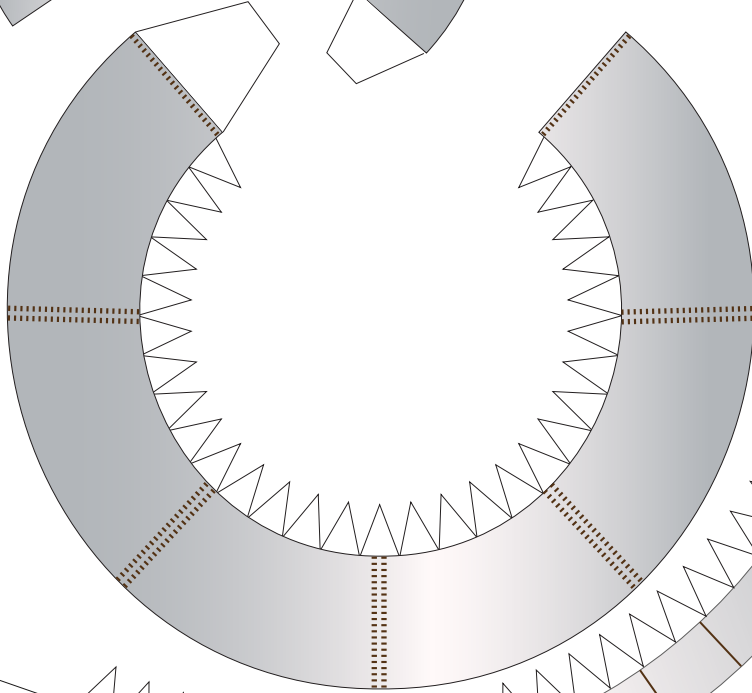
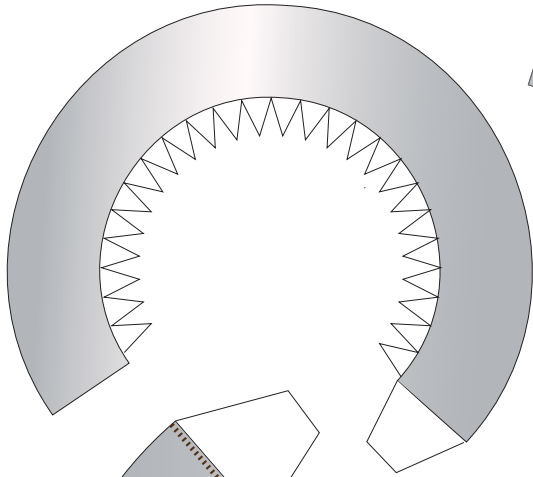
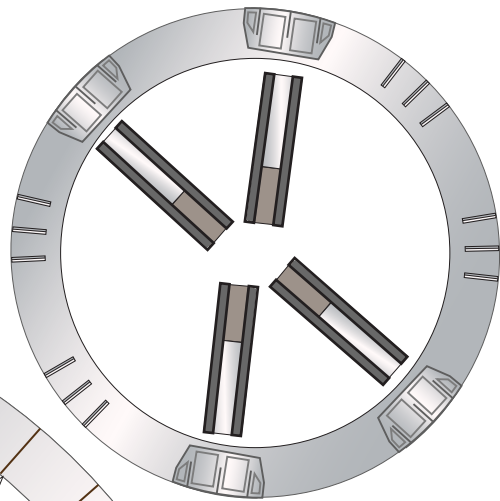
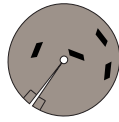
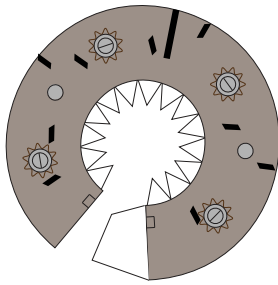

Ch4 vent pipes

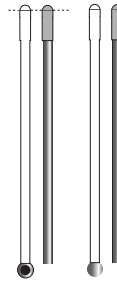

Ch4 vent pipes

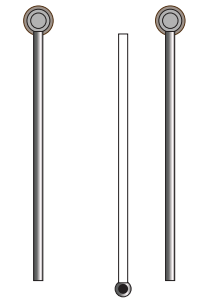
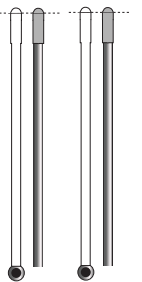

Ch4 press lines

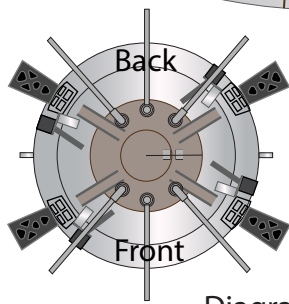

Diagram

Diagram

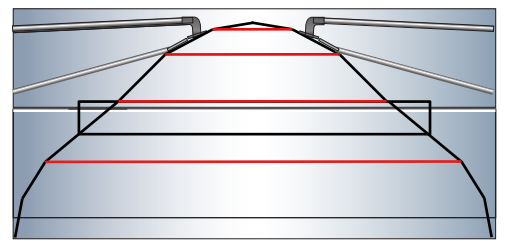



1 cm

1 inch

1:100 Scale

SpaceX Starship B12

Print on Cardstock (110 lbs)

Grid Fins servo motors and Connectors

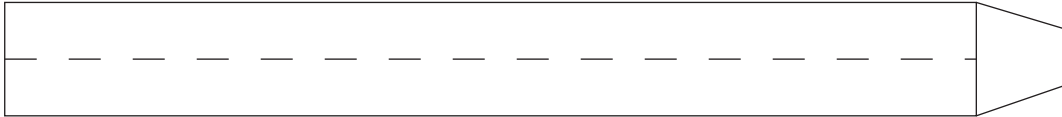
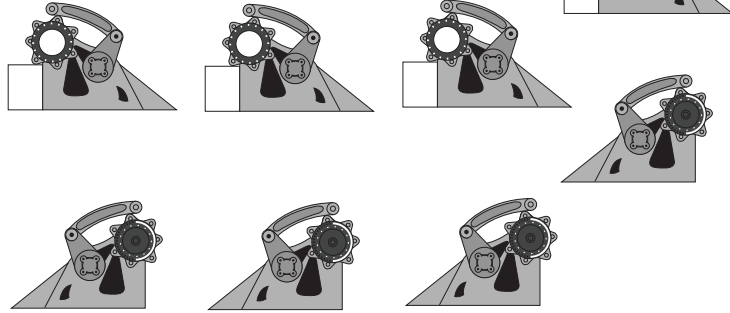
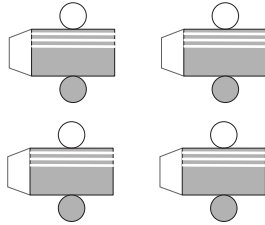
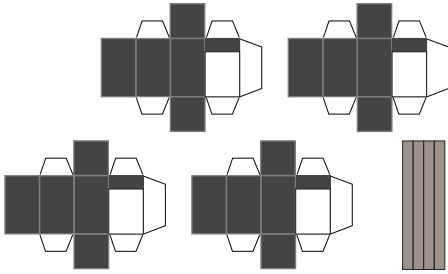

top/middle

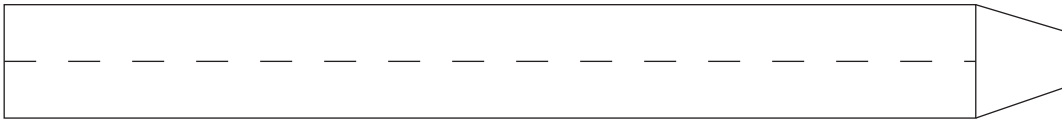
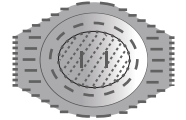
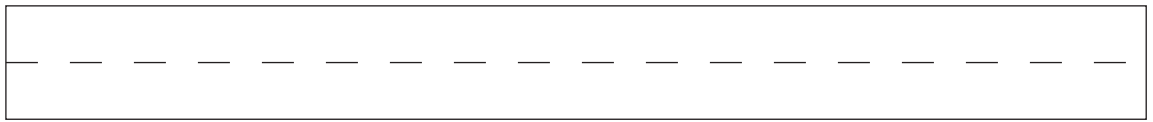

middle/bottom

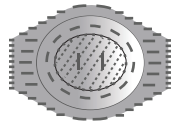

Glue tip of the
Ch4 press line to
cover the black circles

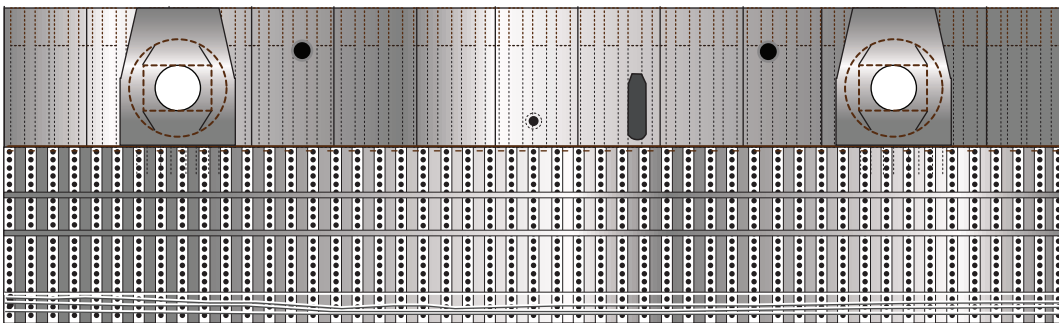
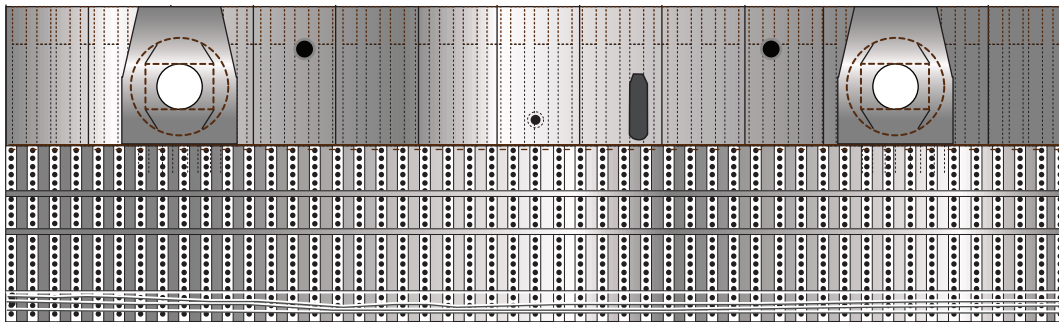

Interior wall
for upper dome
section



1 cm

1 inch

1:100 Scale

SuperHeavy B12 Grid Fins

Print on Cardstock (110 lbs)

Simple version

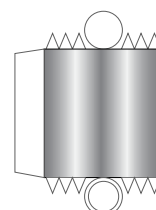
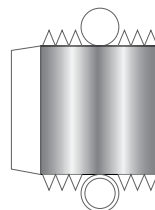
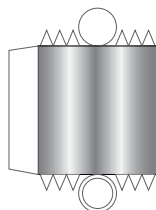
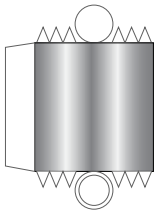
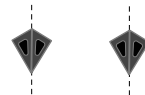
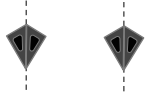
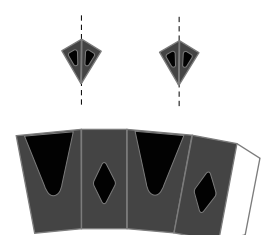
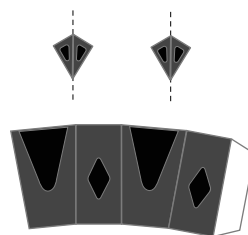
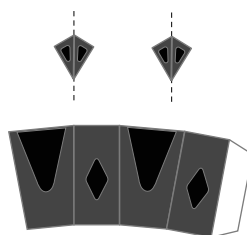
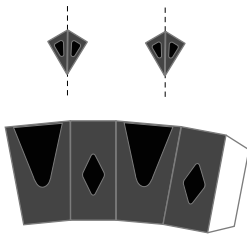
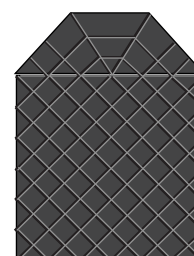
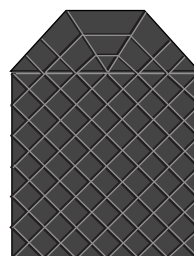
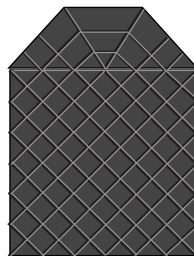
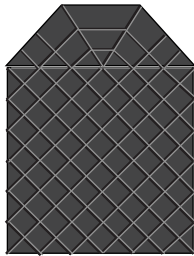
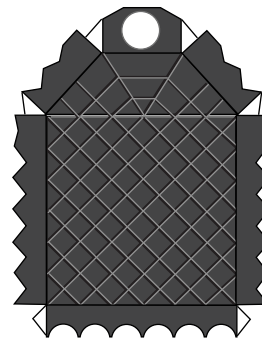
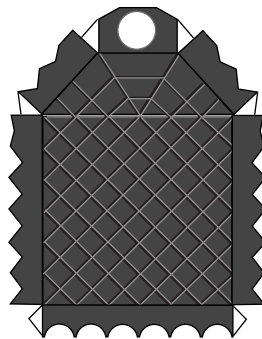
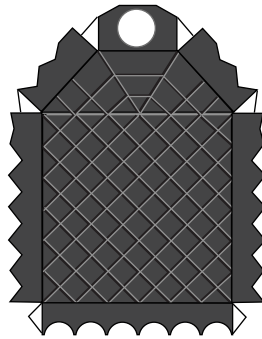
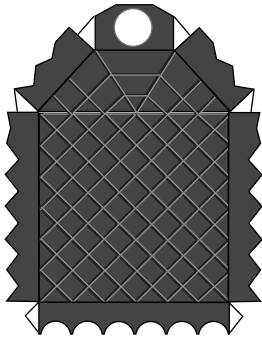



1 cm

1 inch

1:100 Scale

B12 Grid Fins

Back Print

Print on Cardstock (110 lbs)





1 cm

1 inch

1:100 Scale

SuperHeavy B12 Grid Fins

Print on Cardstock (110 lbs)

Detailed version

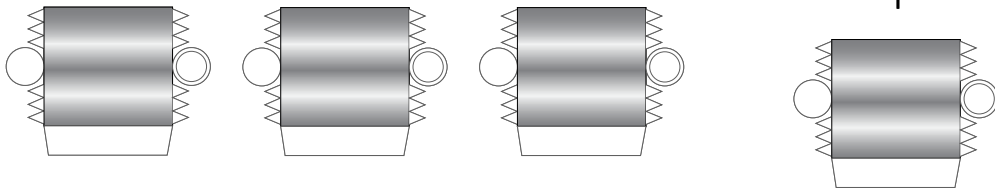
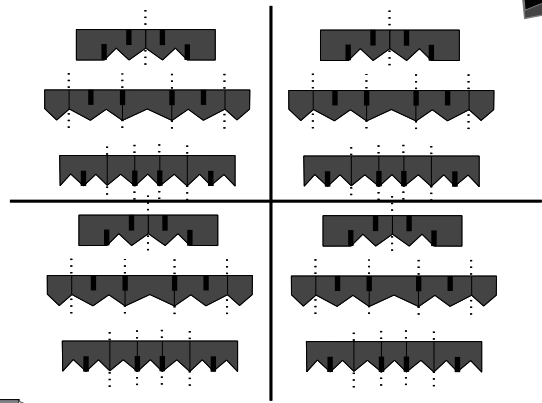
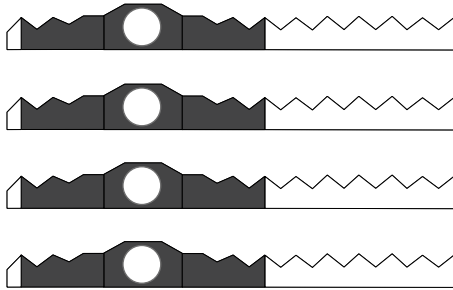
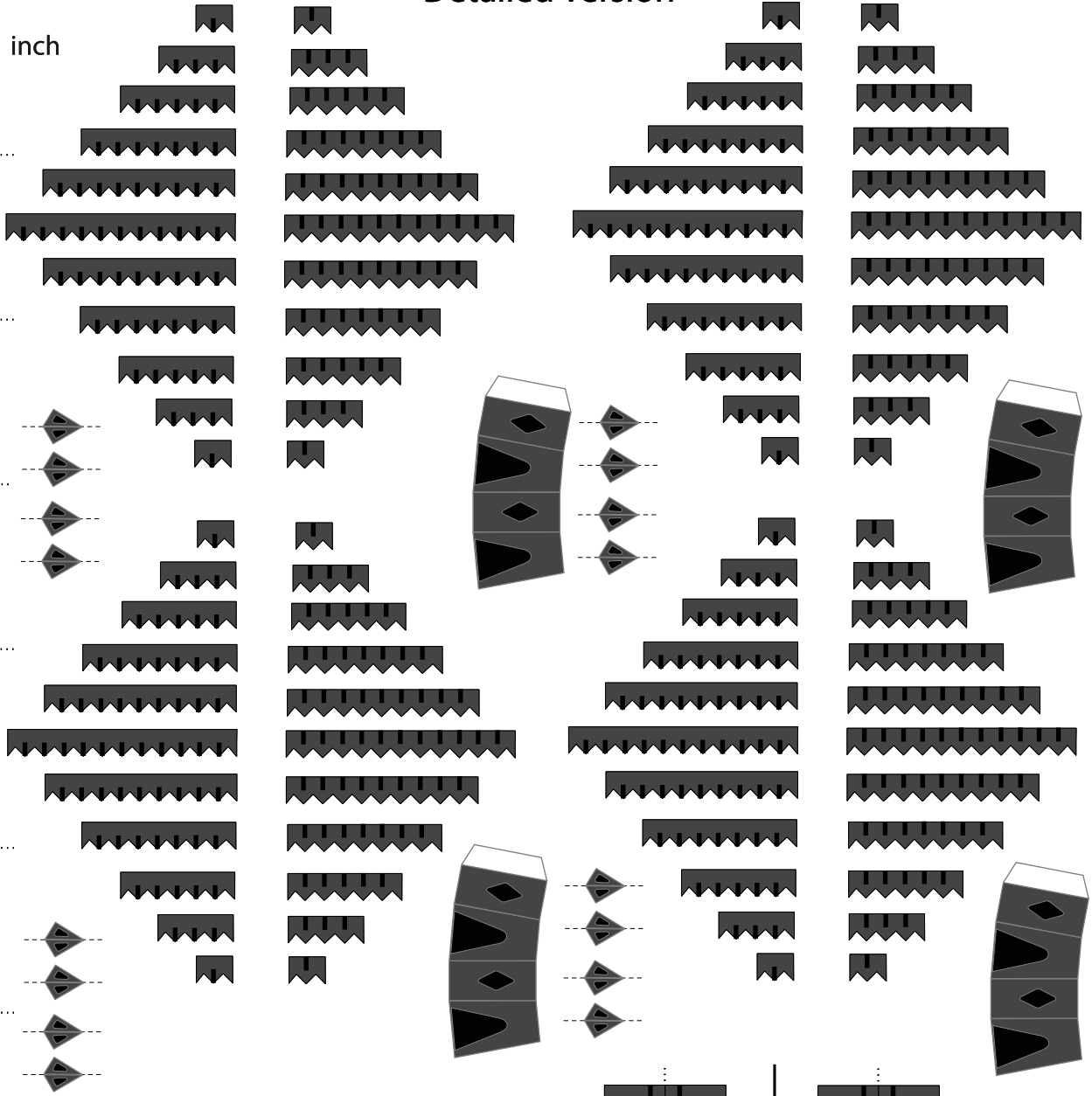
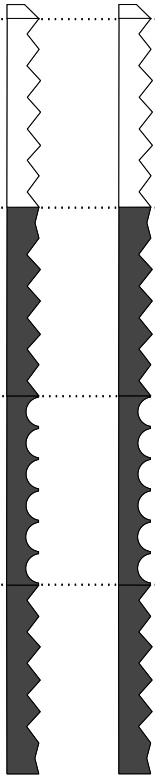



B12 Grid Fins back print

Print on Cardstock (110 lbs)

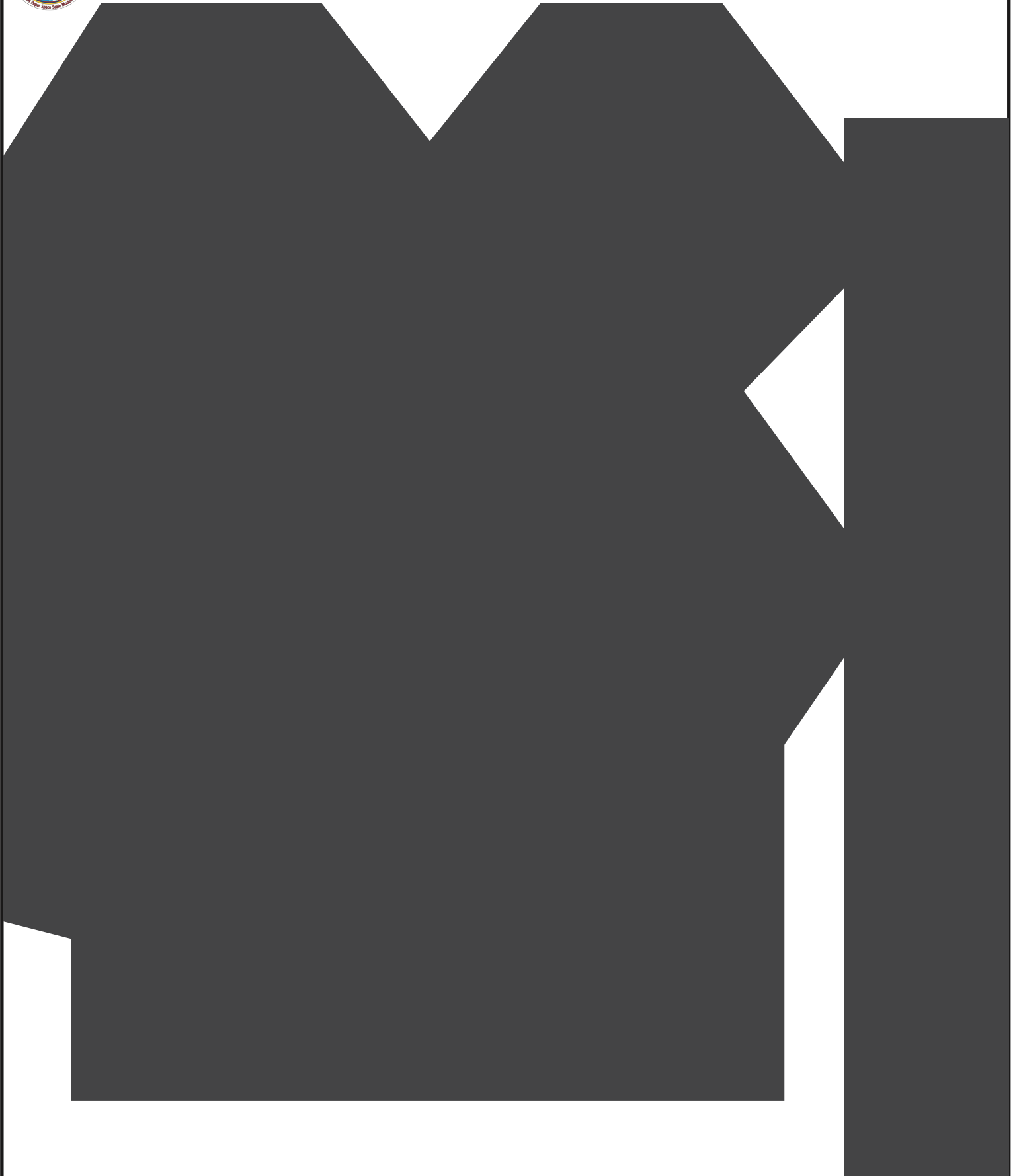



1:100 Scale



Booster 12

Print on Cardstock (110 lbs)

Belly side top

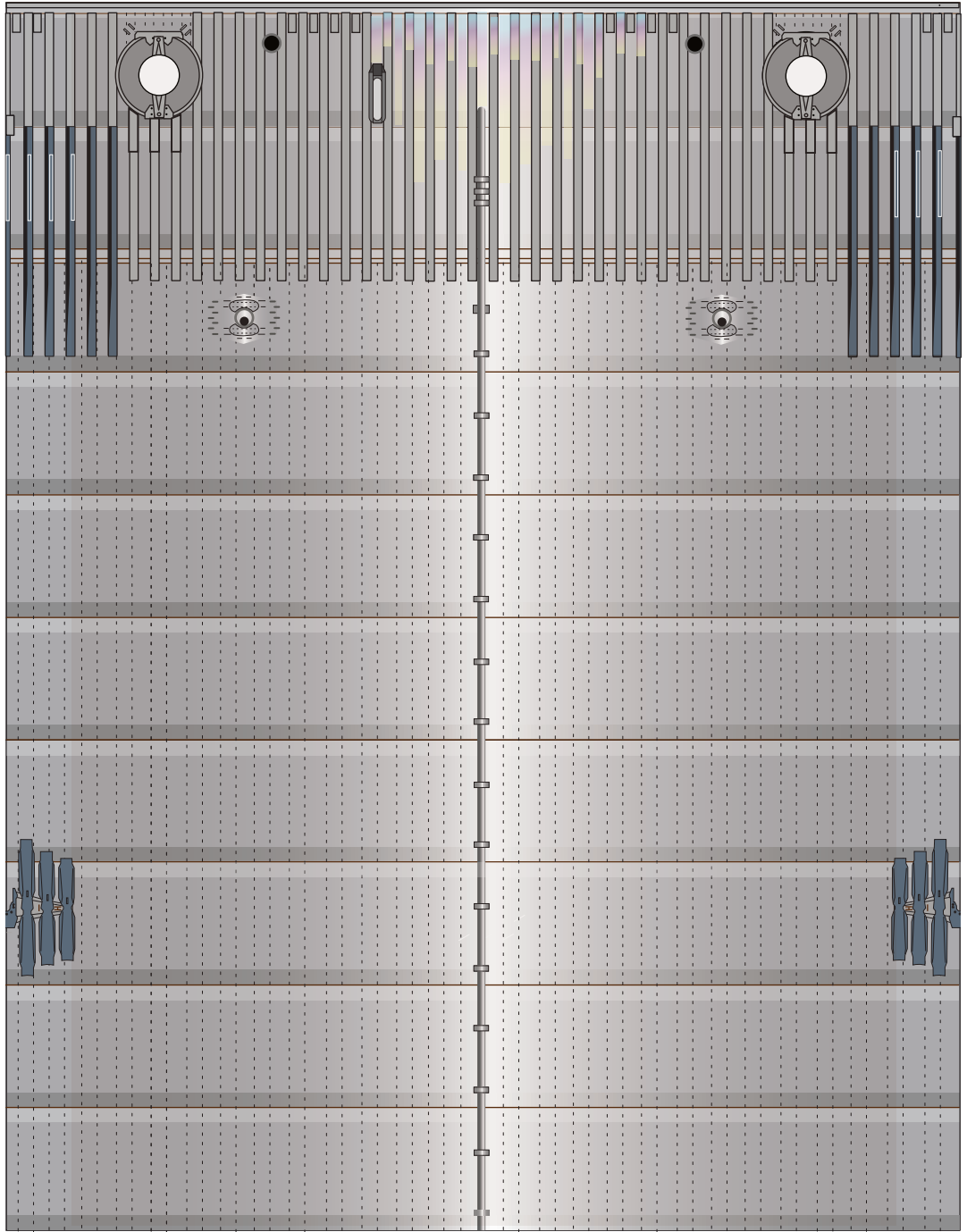
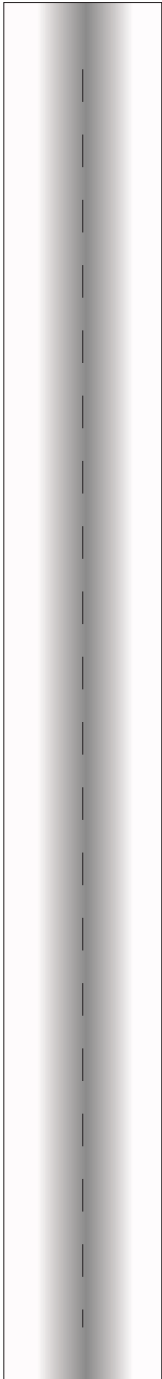
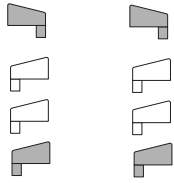



1:100 Scale



Booster 12

Print on Cardstock (110 lbs)

Back side top

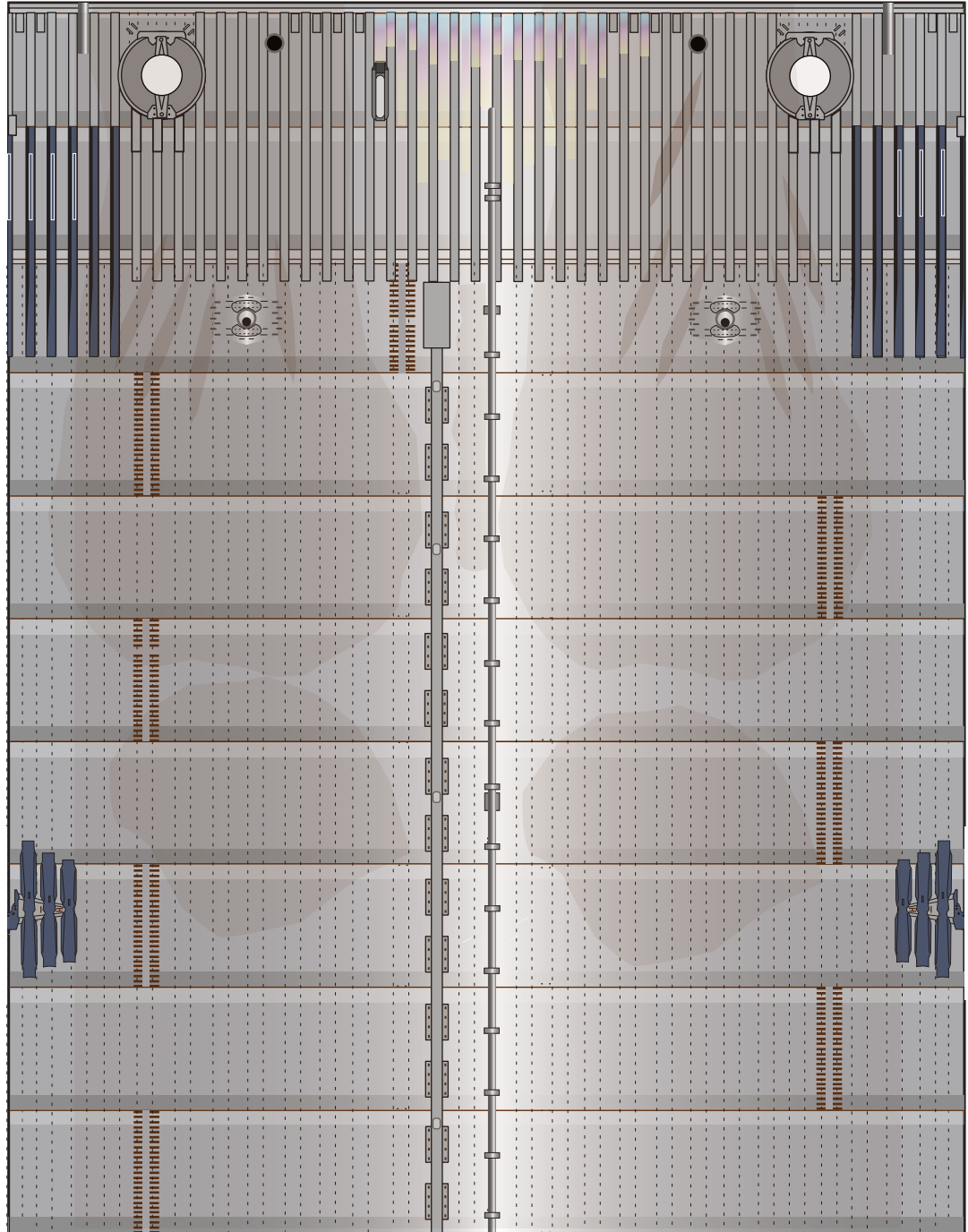
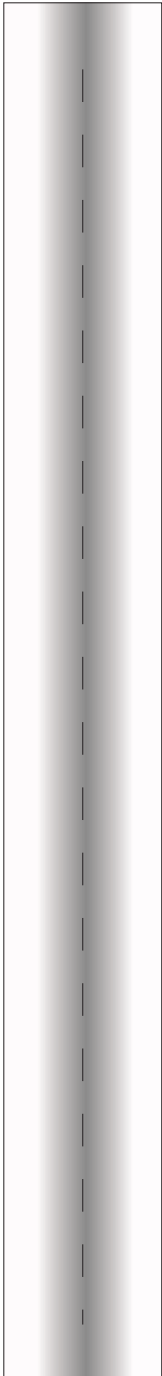



1:100 Scale

Booster 12

Print on Cardstock (110 lbs)
Belly side middle

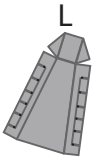
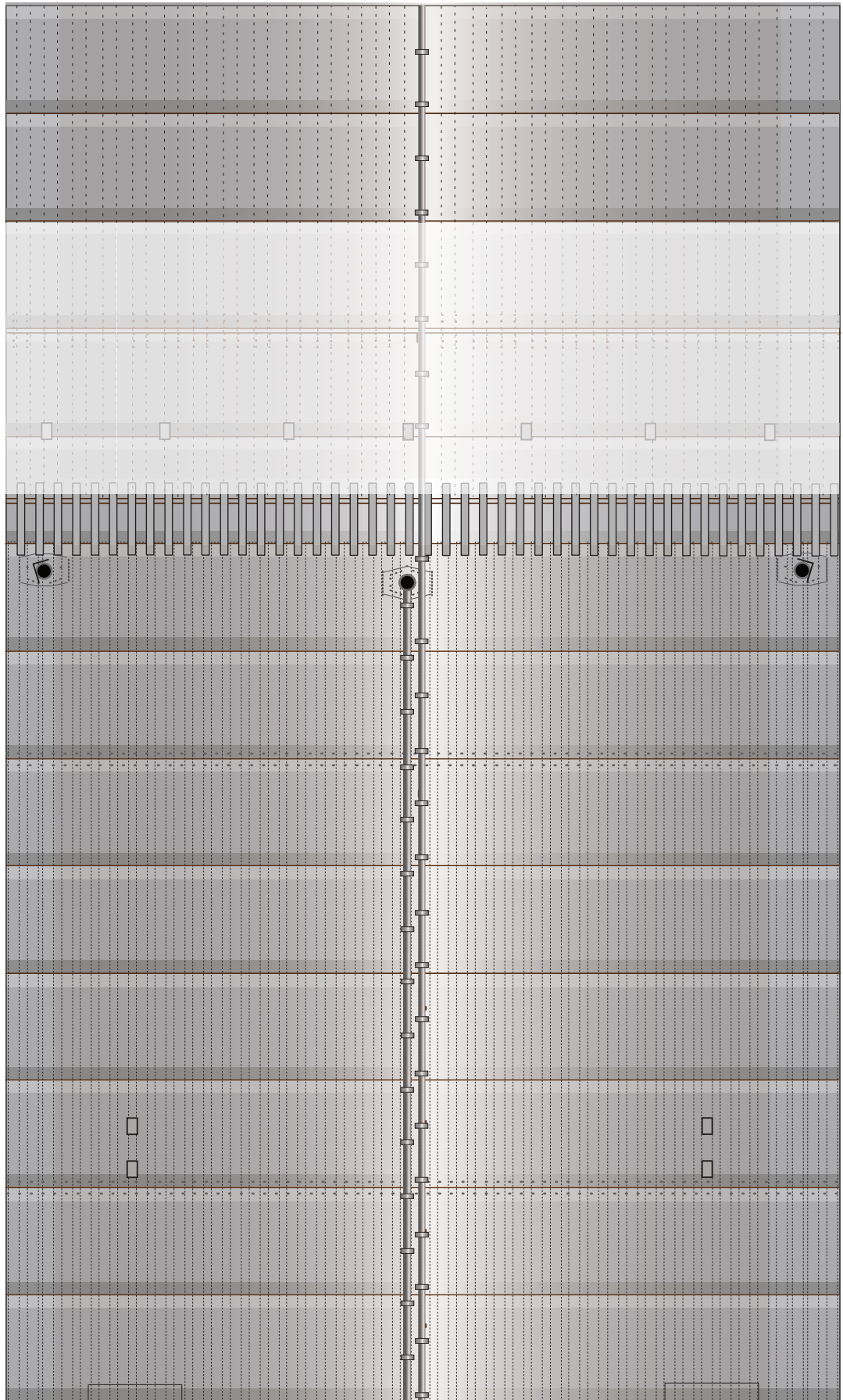
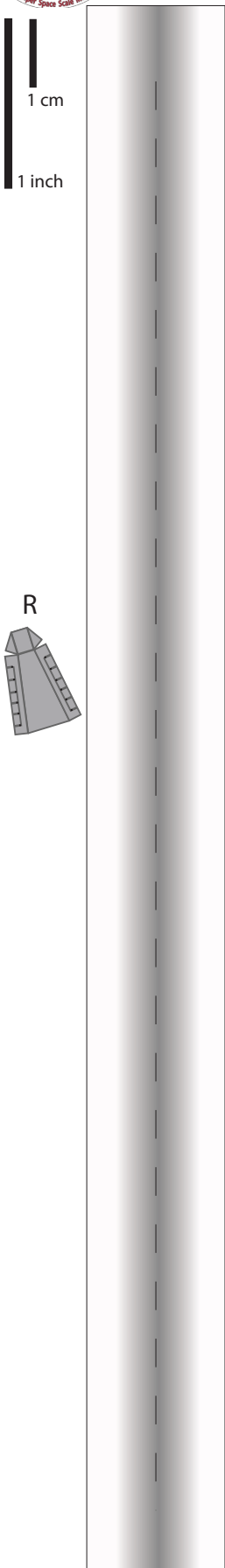



1:100 Scale

Booster 12

Print on Cardstock (110 lbs)
Back side middle

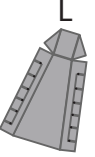
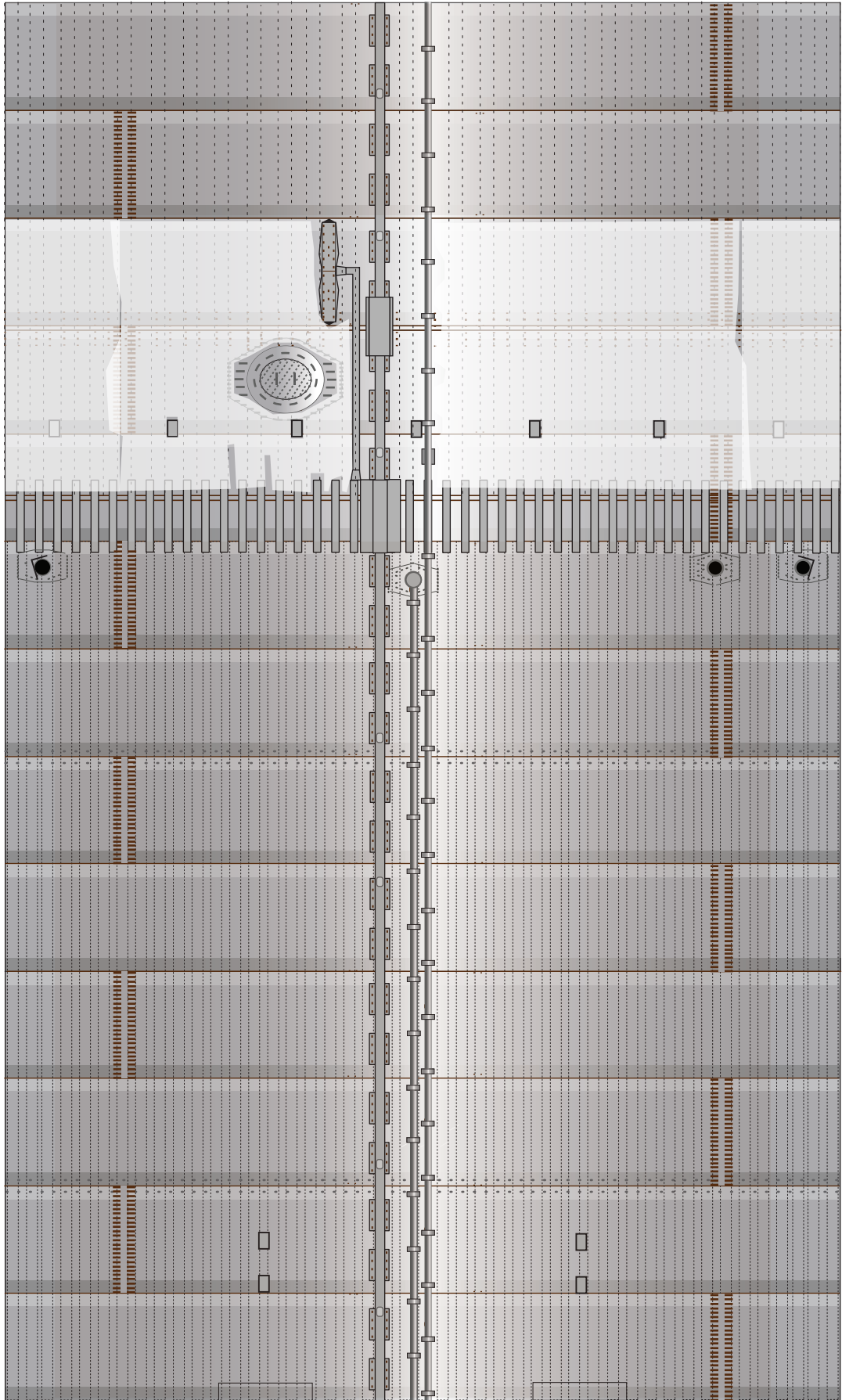
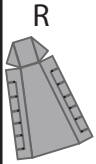



1:100 Scale

Booster 12

Print on Cardstock (110 lbs)
Belly side bottom

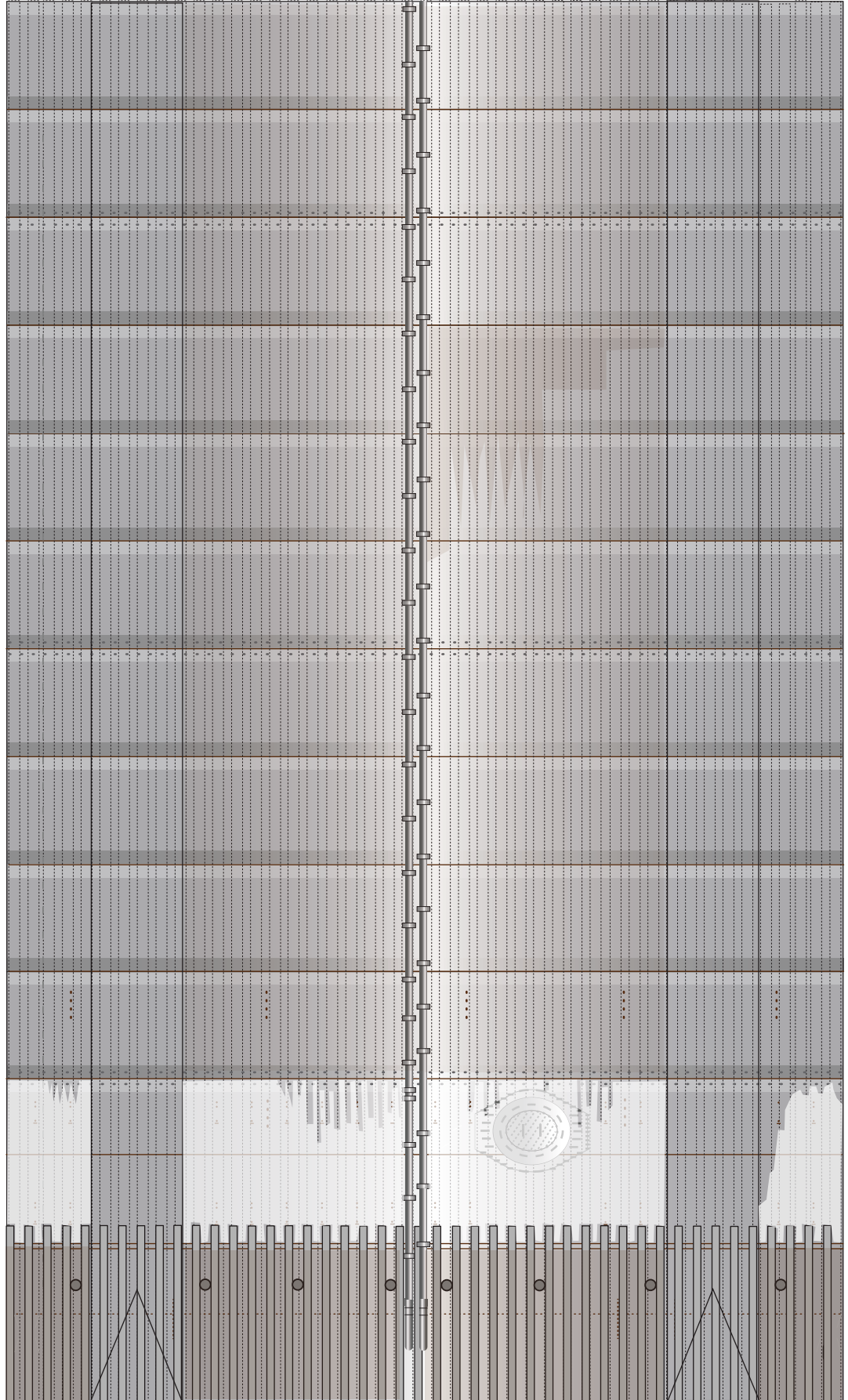
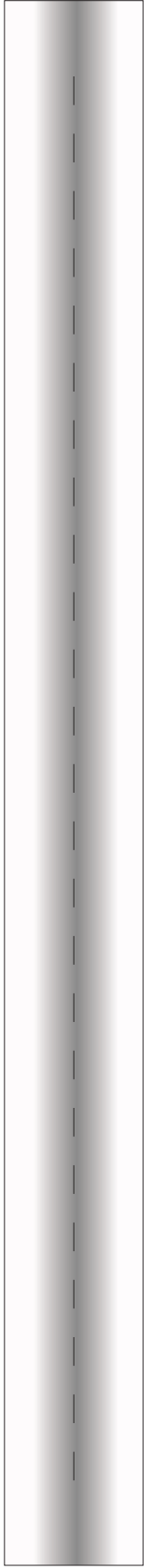



1:100 Scale

Booster 12

Print on Cardstock (110 lbs)
Back side bottom

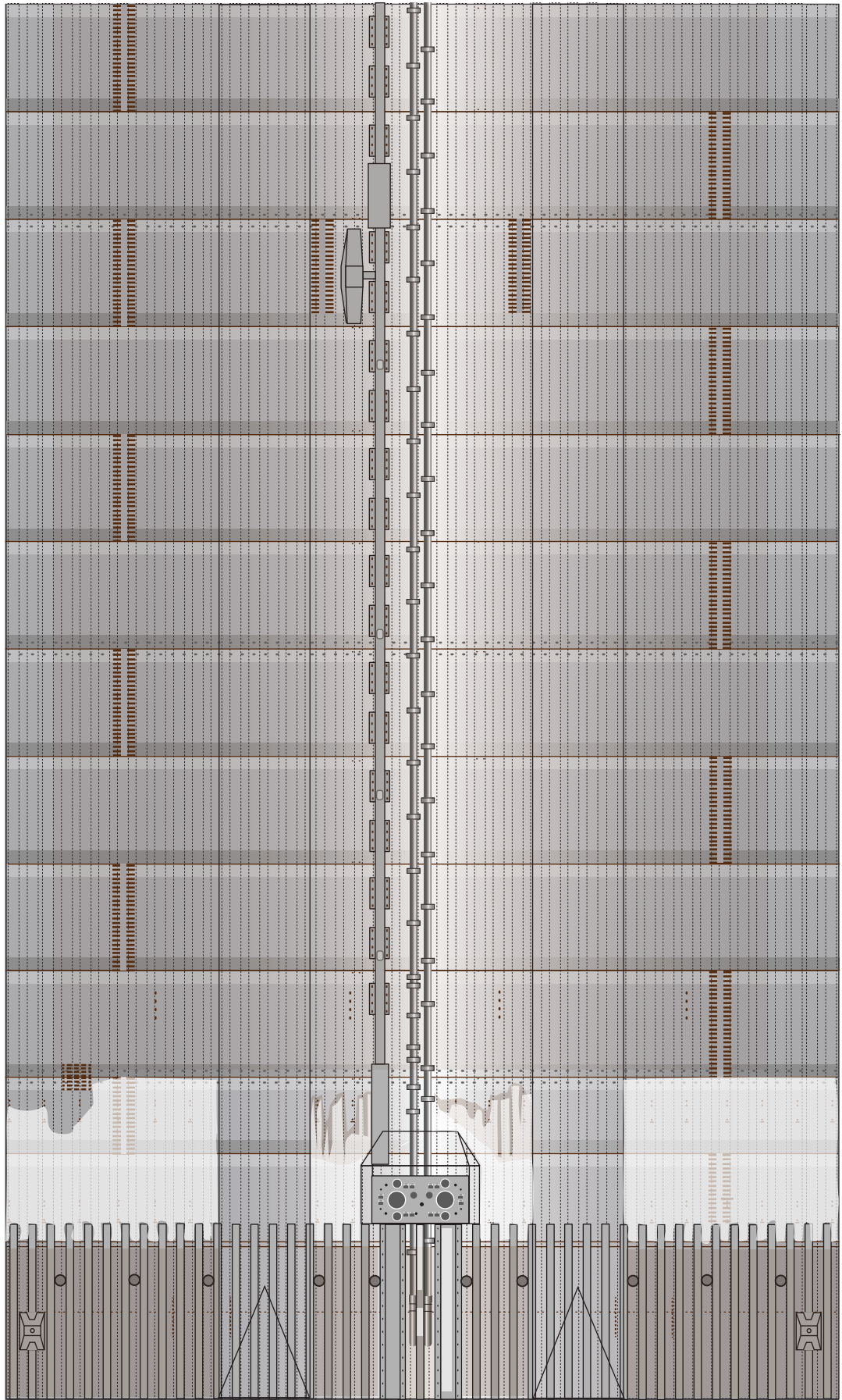
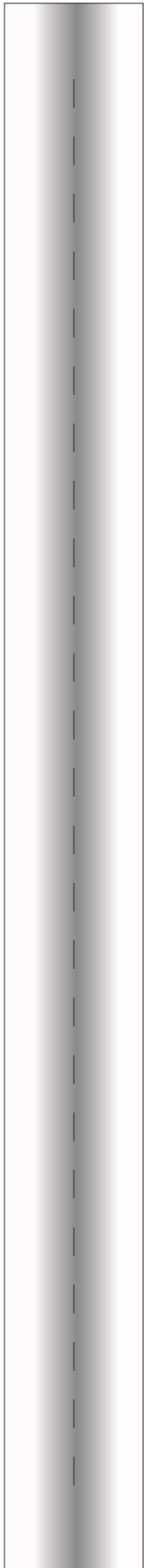



1:100 Scale



SpaceX Heavy booster 12

Print on cardstock (110 lbs)

COPV covers

FRONT

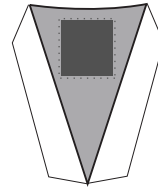
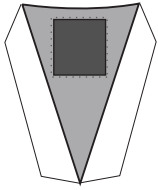
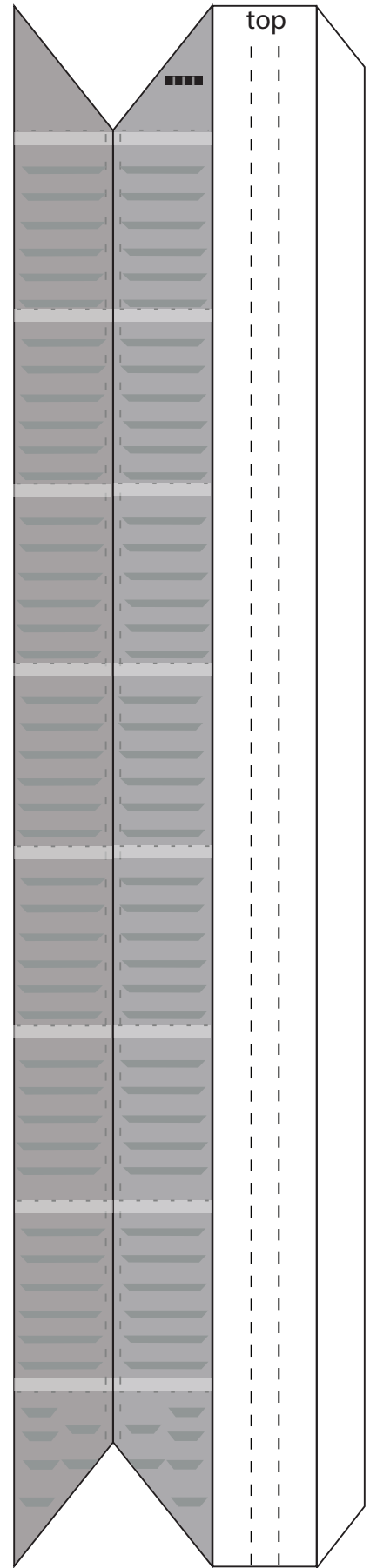
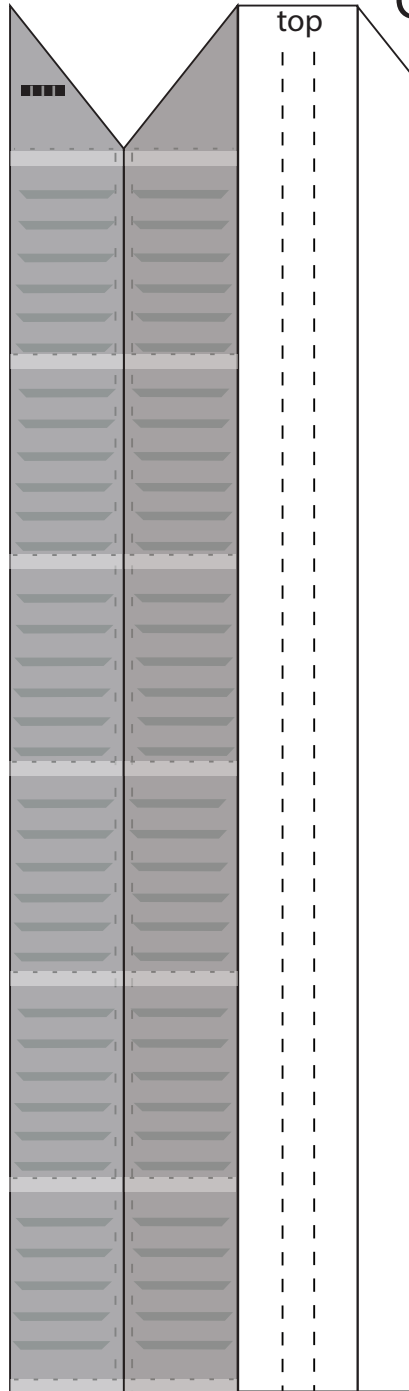

COPV



Glue COPV

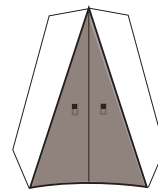
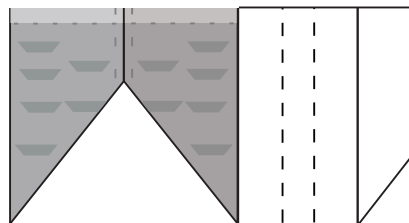
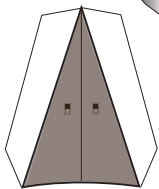
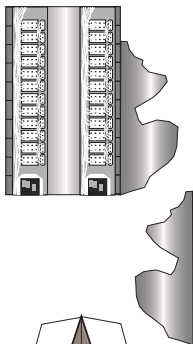



1:100 Scale

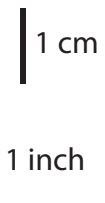

SpaceX Heavy booster 12

Printed on cardstock (110 lbs)

Back print page

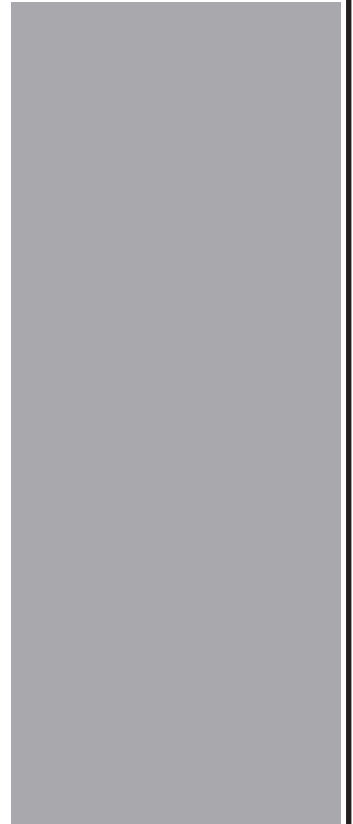



1:100 Scale



SpaceX Heavy booster 12

Print on cardstock (110 lbs)

COPV covers

Umbilical side

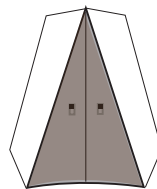
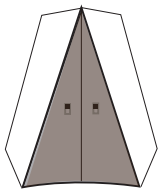
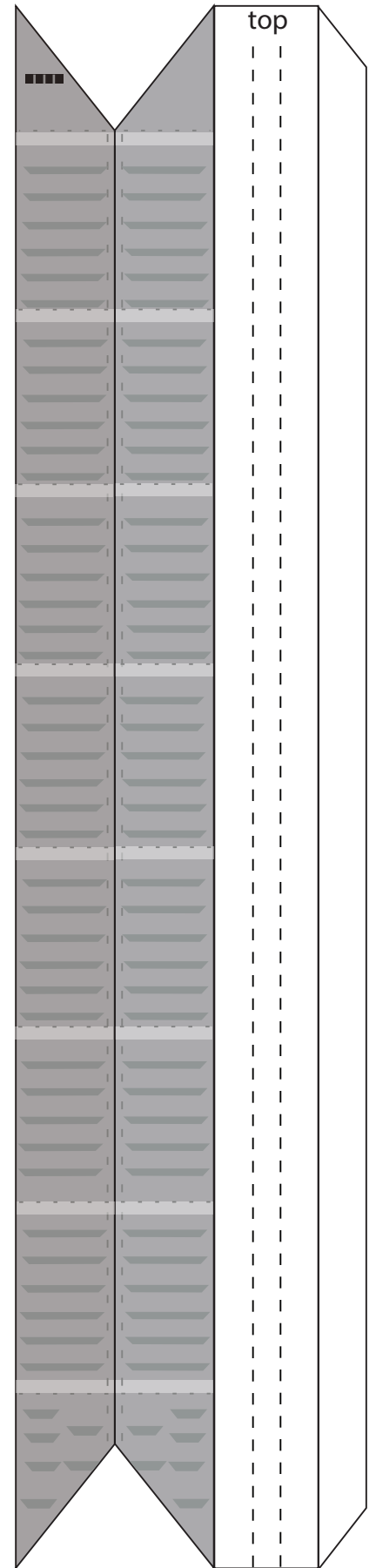
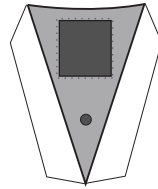
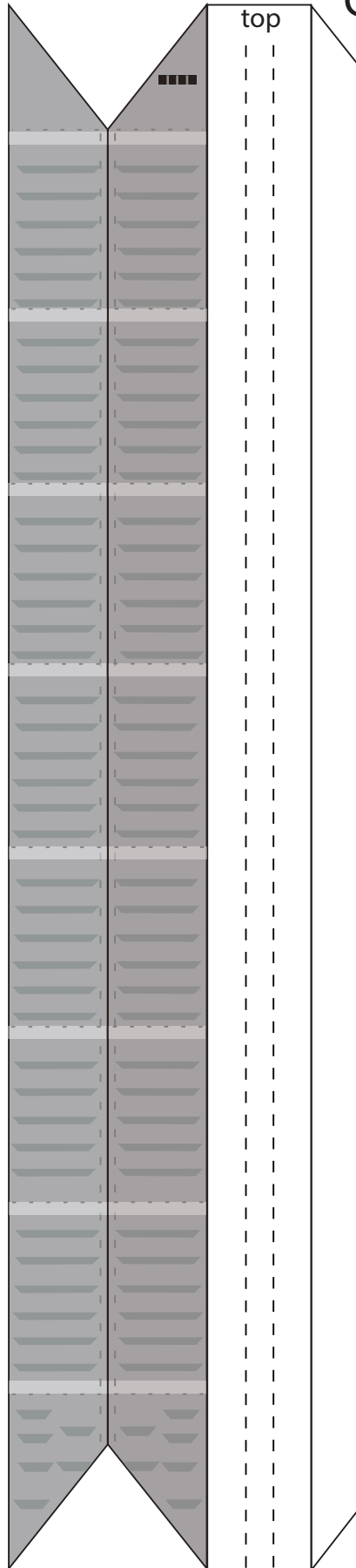
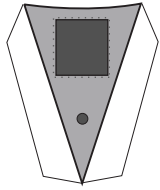



1:100 Scale

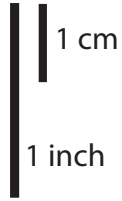

SpaceX Starship B12

Formers for top section

Print on Cardstock (110 lbs)

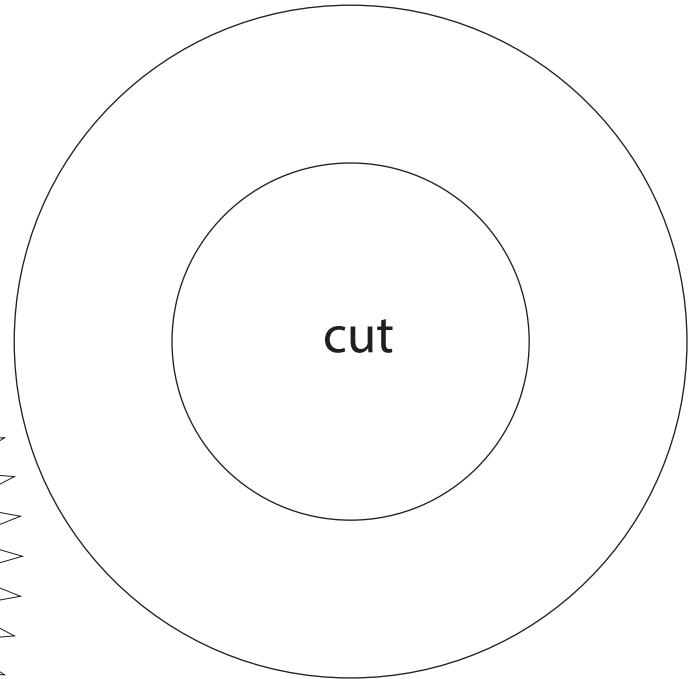
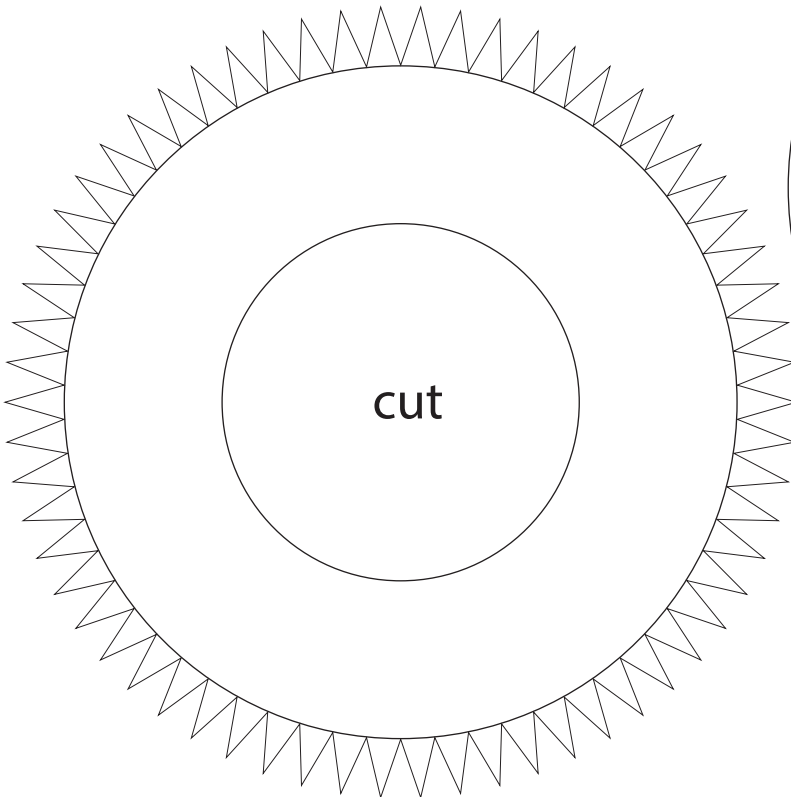
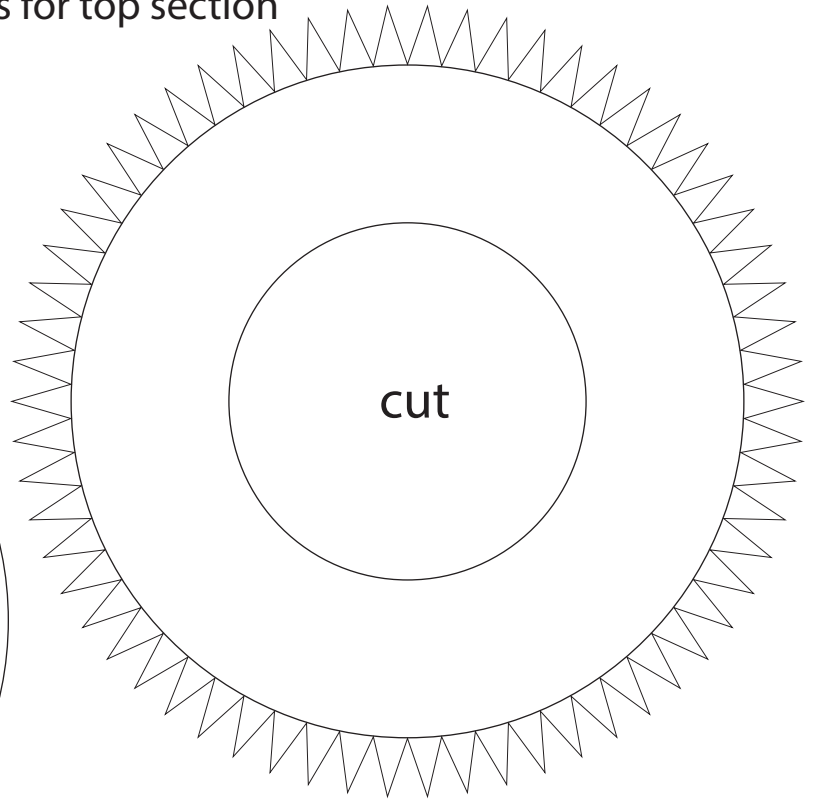
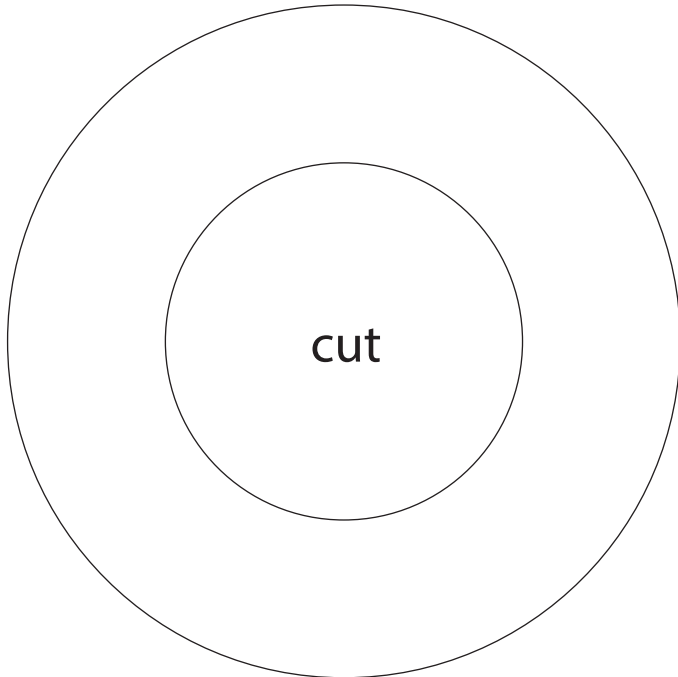

IMPORTANT
Top former is glued 42 mm from top edge of top booster section.
Bottom former is glued 20 mm from bottom edge of top booster section.



1:100 Scale



SpaceX Starship B12

Print on Cardstock (110 lbs)

Formers for middle body

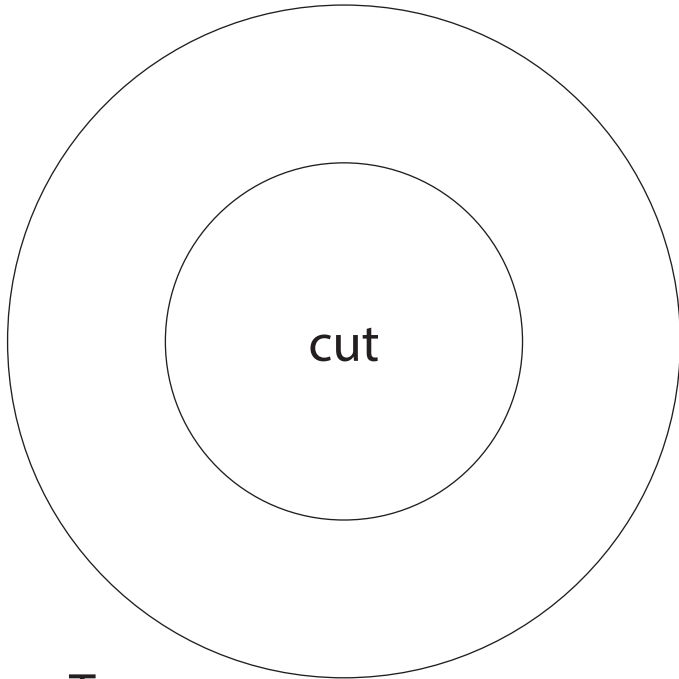

Top

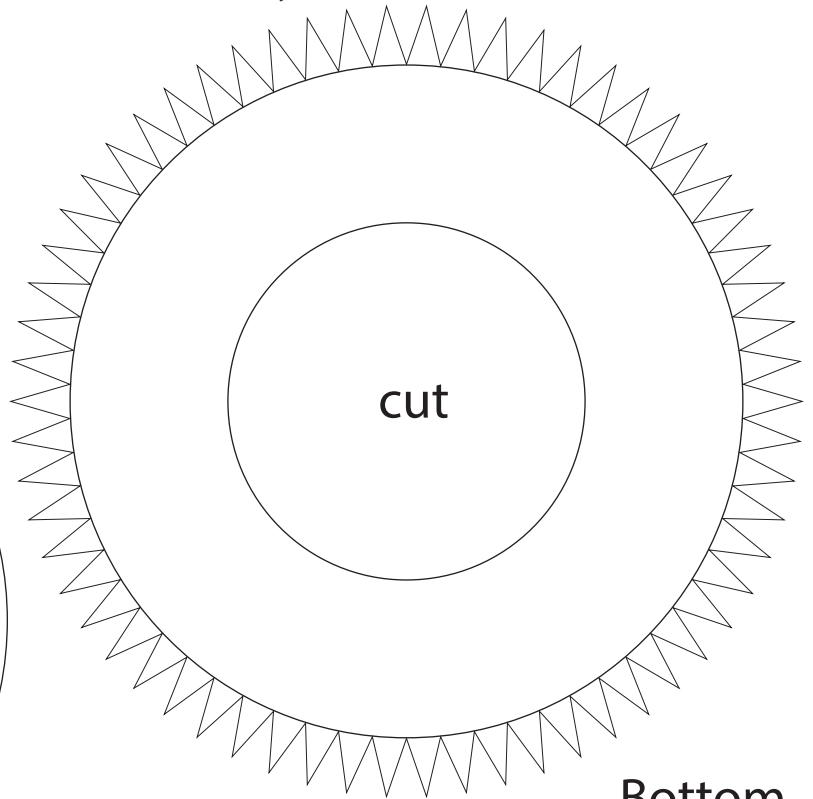

Bottom

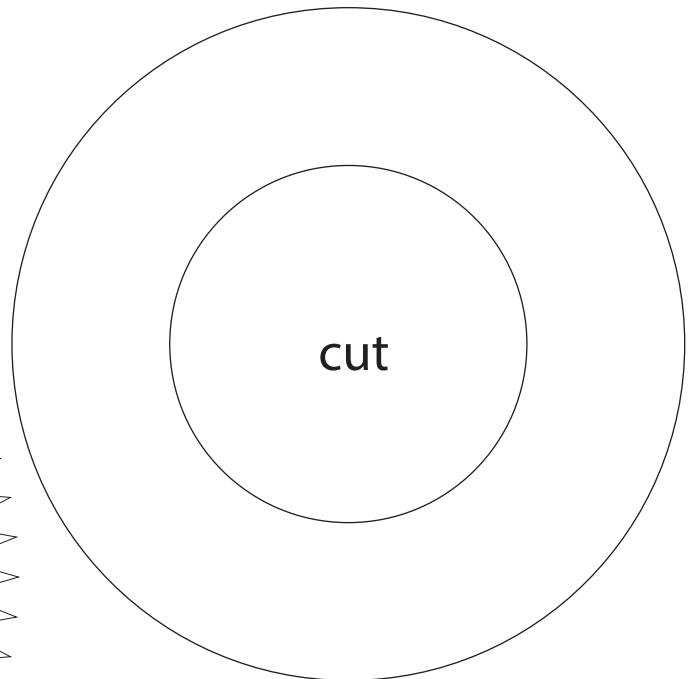
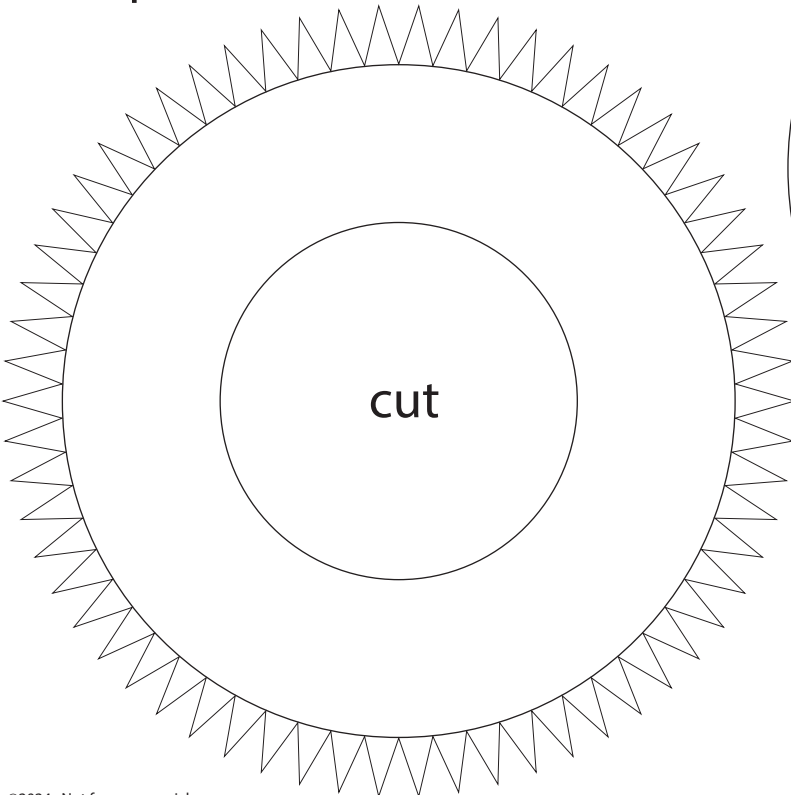

IMPORTANT

Top former is glued 20 mm from top edge of middle booster section. Bottom former is glued 20 mm from bottom edge of middle booster section.



1:100 Scale



SpaceX Starship B12

Print on Cardstock (110 lbs)

Formers for bottom body

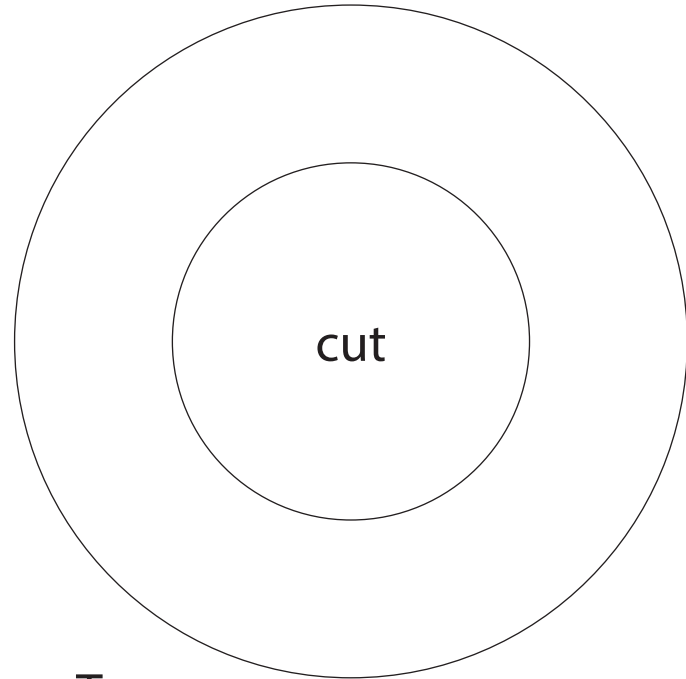

Top

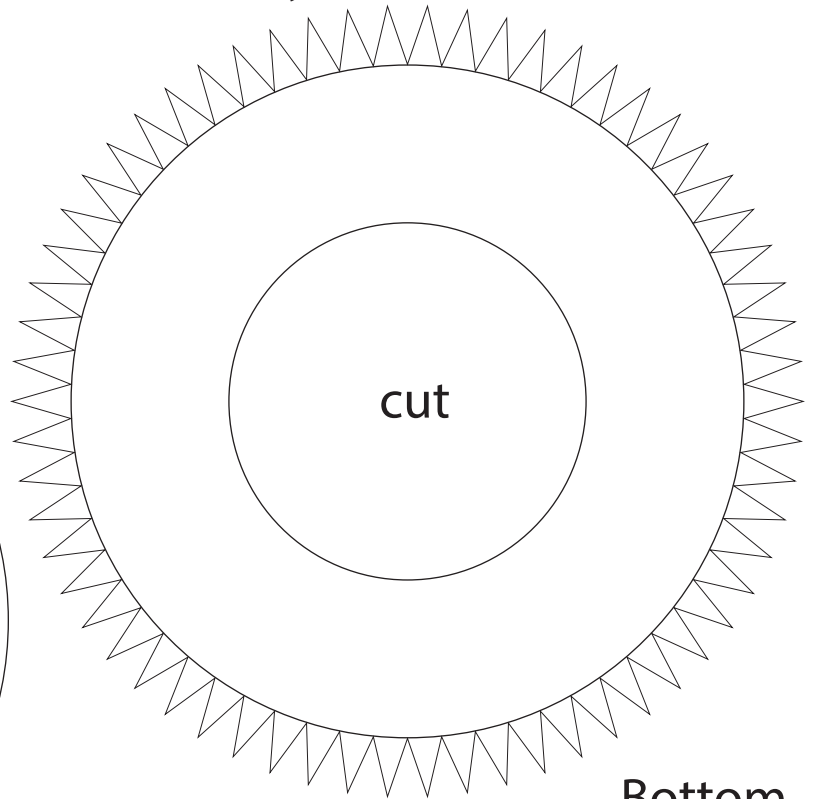

Bottom

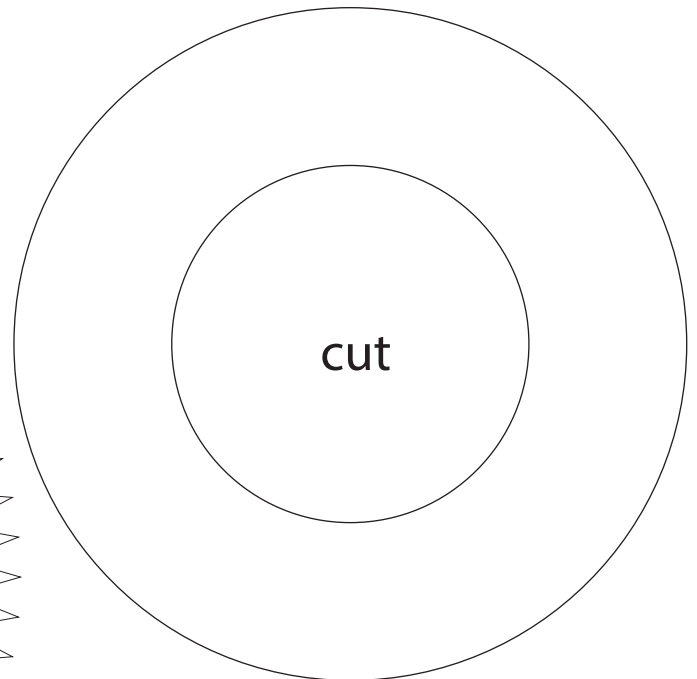
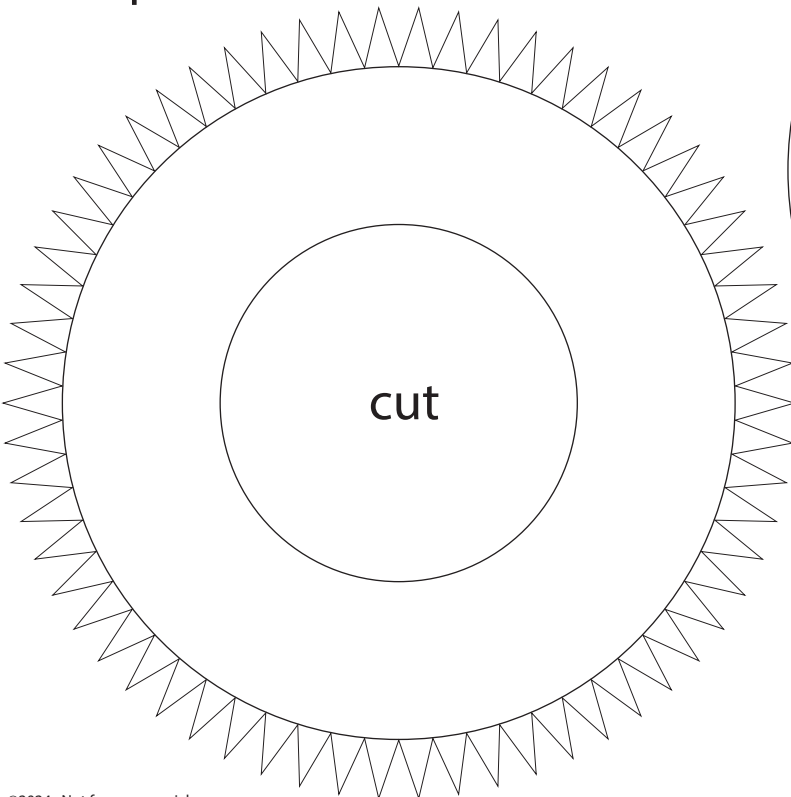

IMPORTANT

Top former is glued 20 mm from top edge of bottom booster section.
Bottom former is glued 19 mm from bottom edge of bottom booster section.



1 cm

1 inch

1:100 Scale

SpaceX SuperHeavy

Print on Cardstock (110 lbs)

Outer Raptor ring

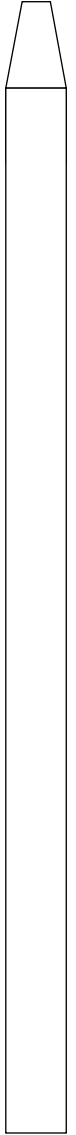
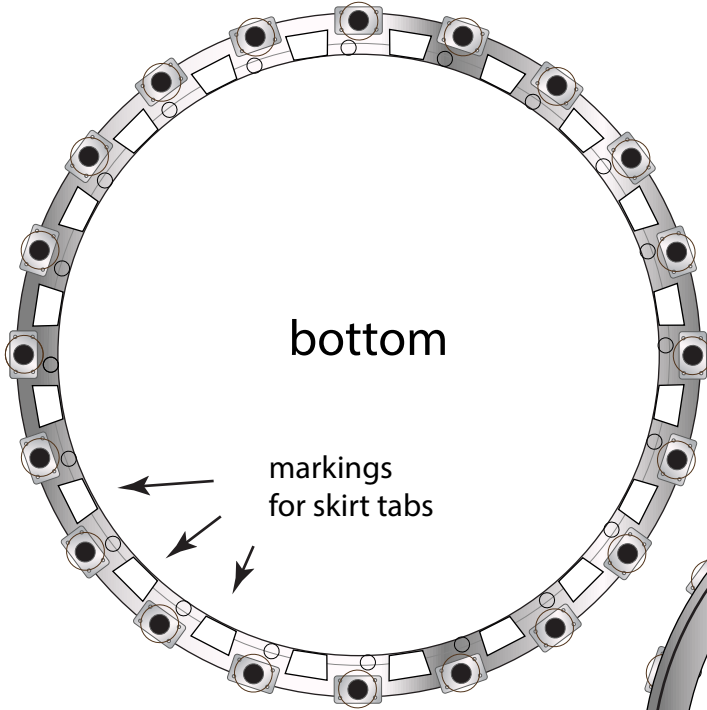

Engine section interior layer





1 cm

1 inch

1:100 Scale

SpaceX Heavy Booster 12

Print on Cardstock (90 lbs)

Skirt for engine section

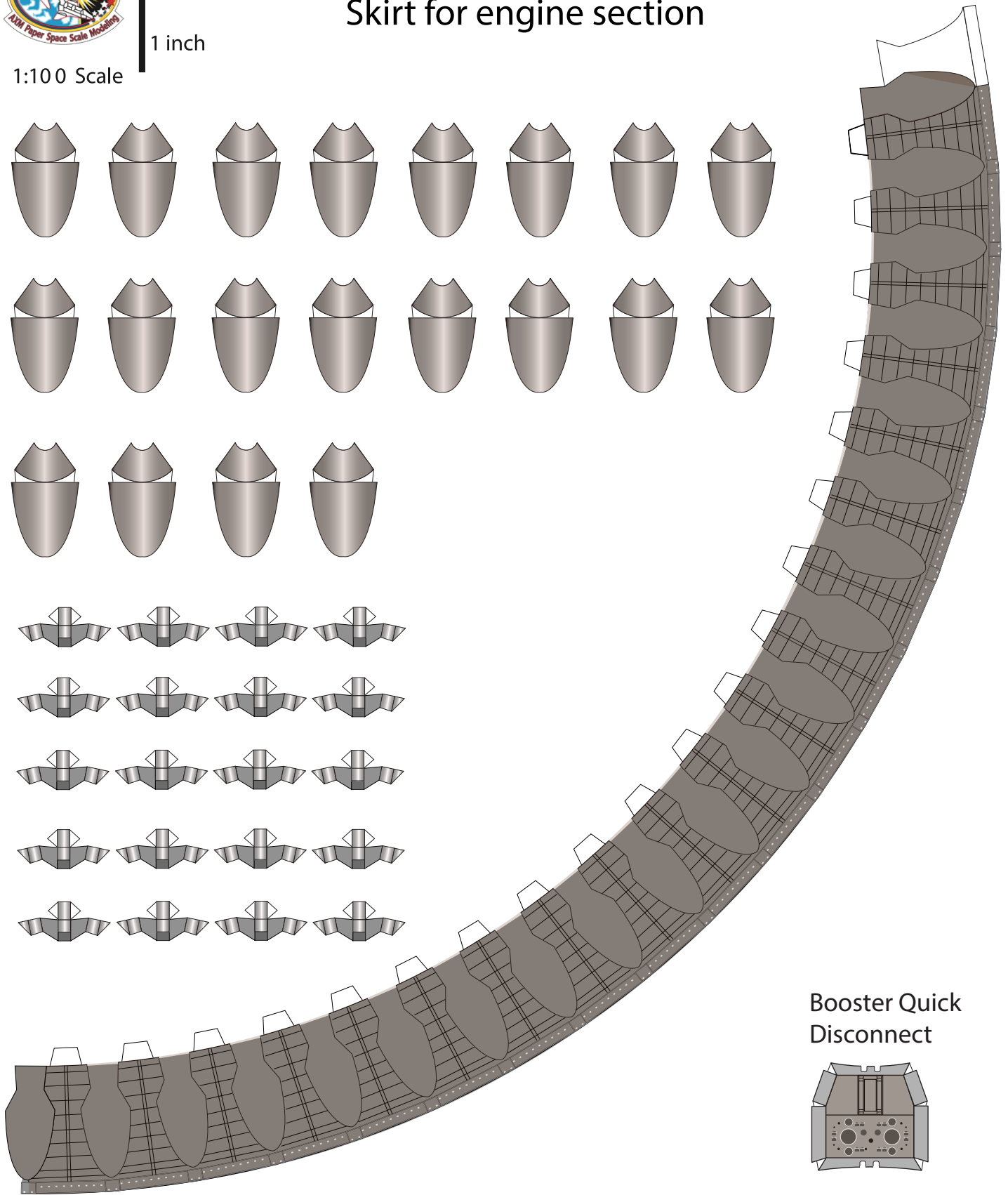
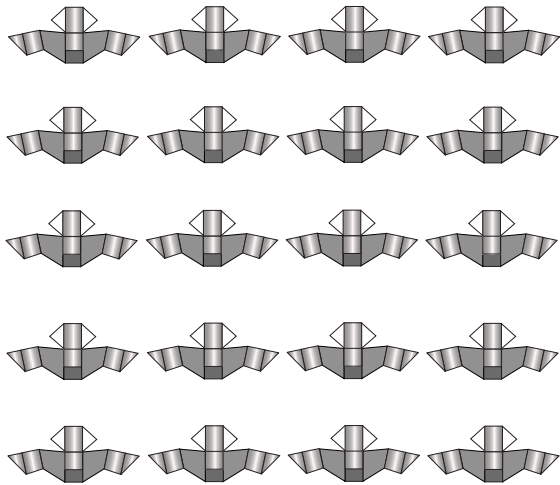
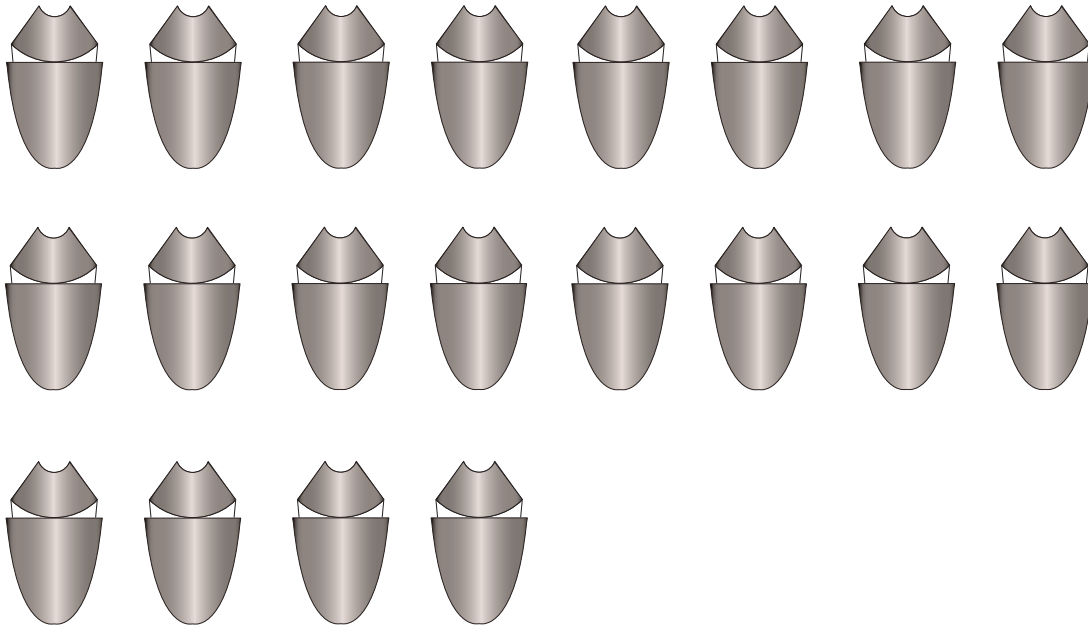

Booster Quick Disconnect

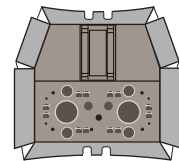

Place 2 magnets on the back to match with magnets from OLM's QD arm



1 cm

1 inch

1:100 Scale

SpaceX Heavy Booster 12

Skirt floor and wall

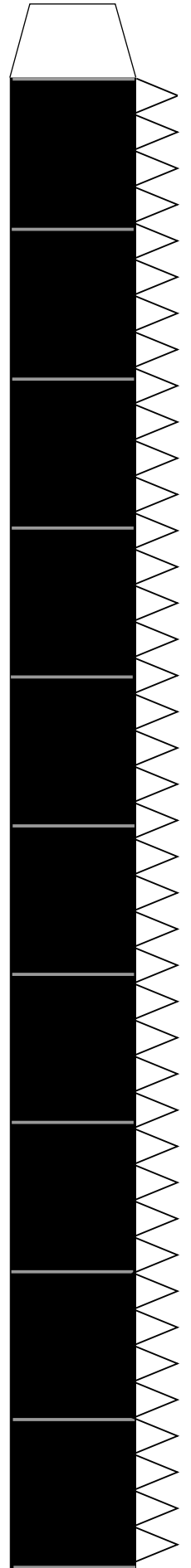
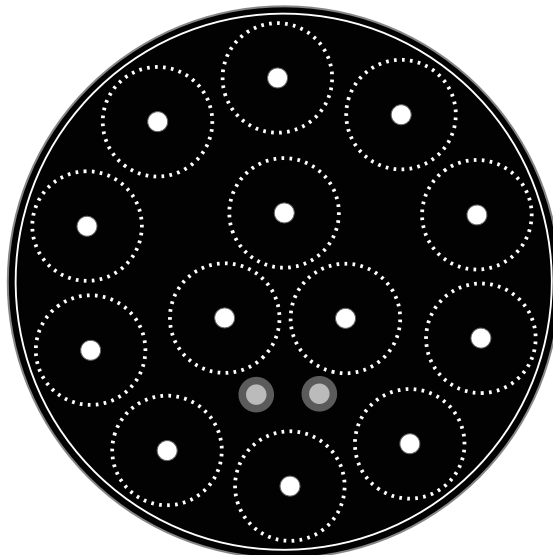
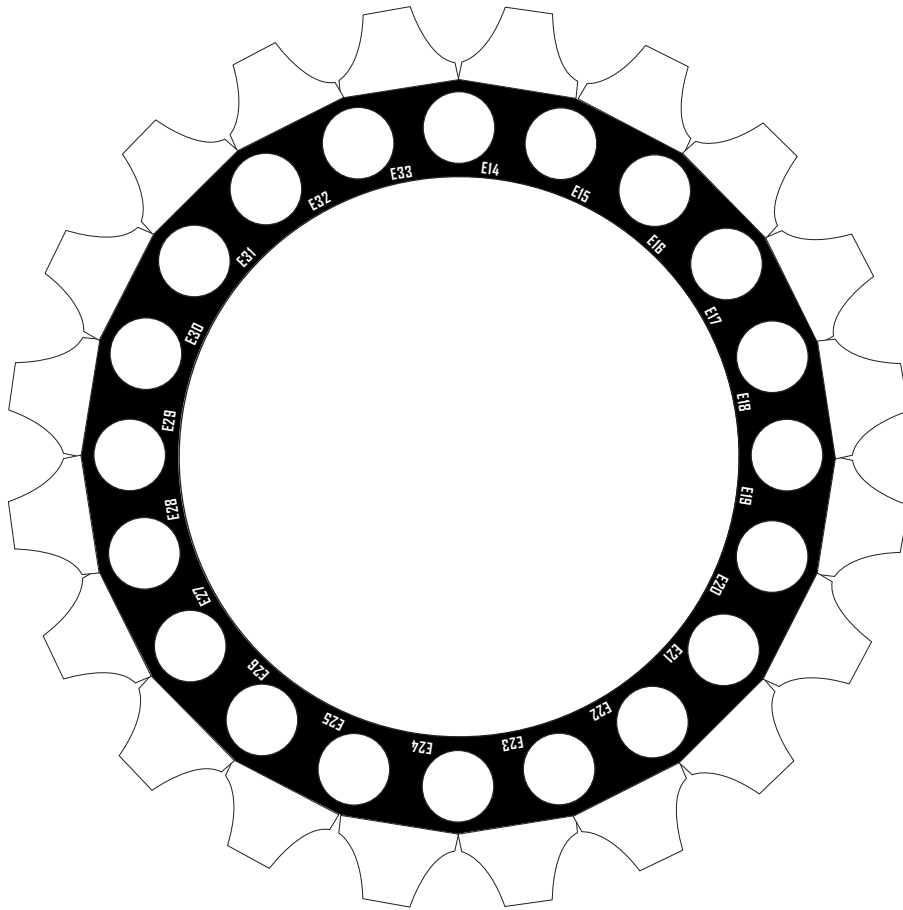

Print on Cardstock (90 lbs)



1 cm

B12 inner Raptor covers

Print on cardstock

1 inch

1:100 Scale

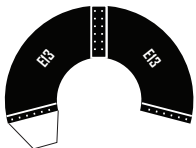
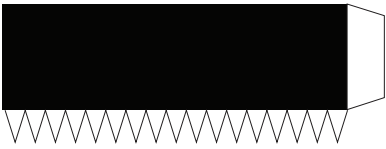
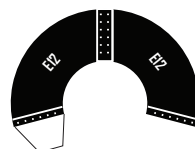
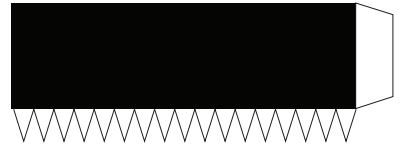
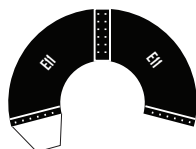
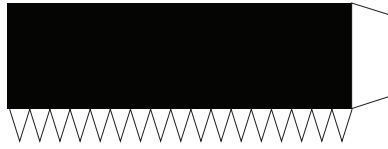
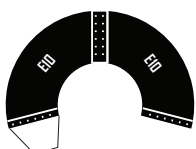
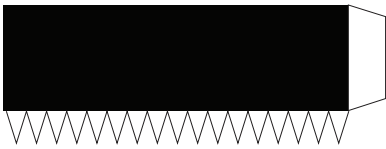
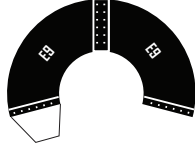
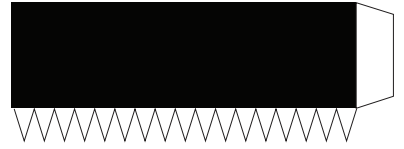
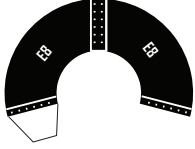
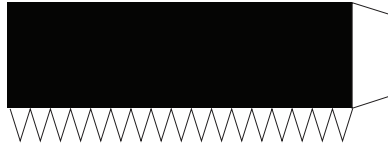
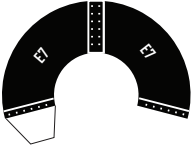
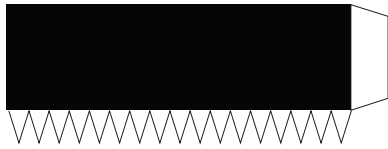
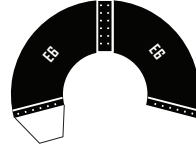
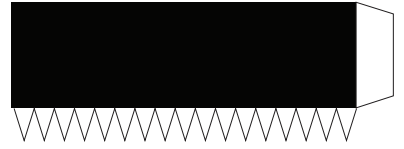
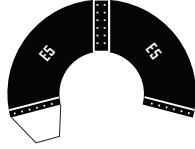
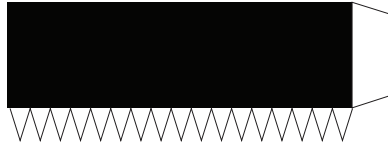
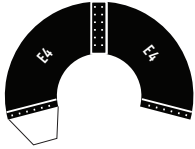
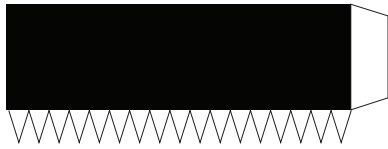
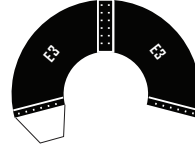
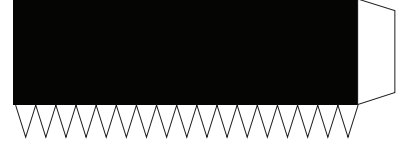
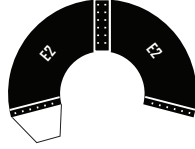
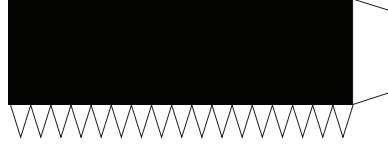
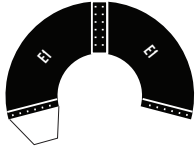



1 cm

SuperHeavy Raptors B12

Print on Cardstock (110 lbs)

1 inch

1:100 Scale

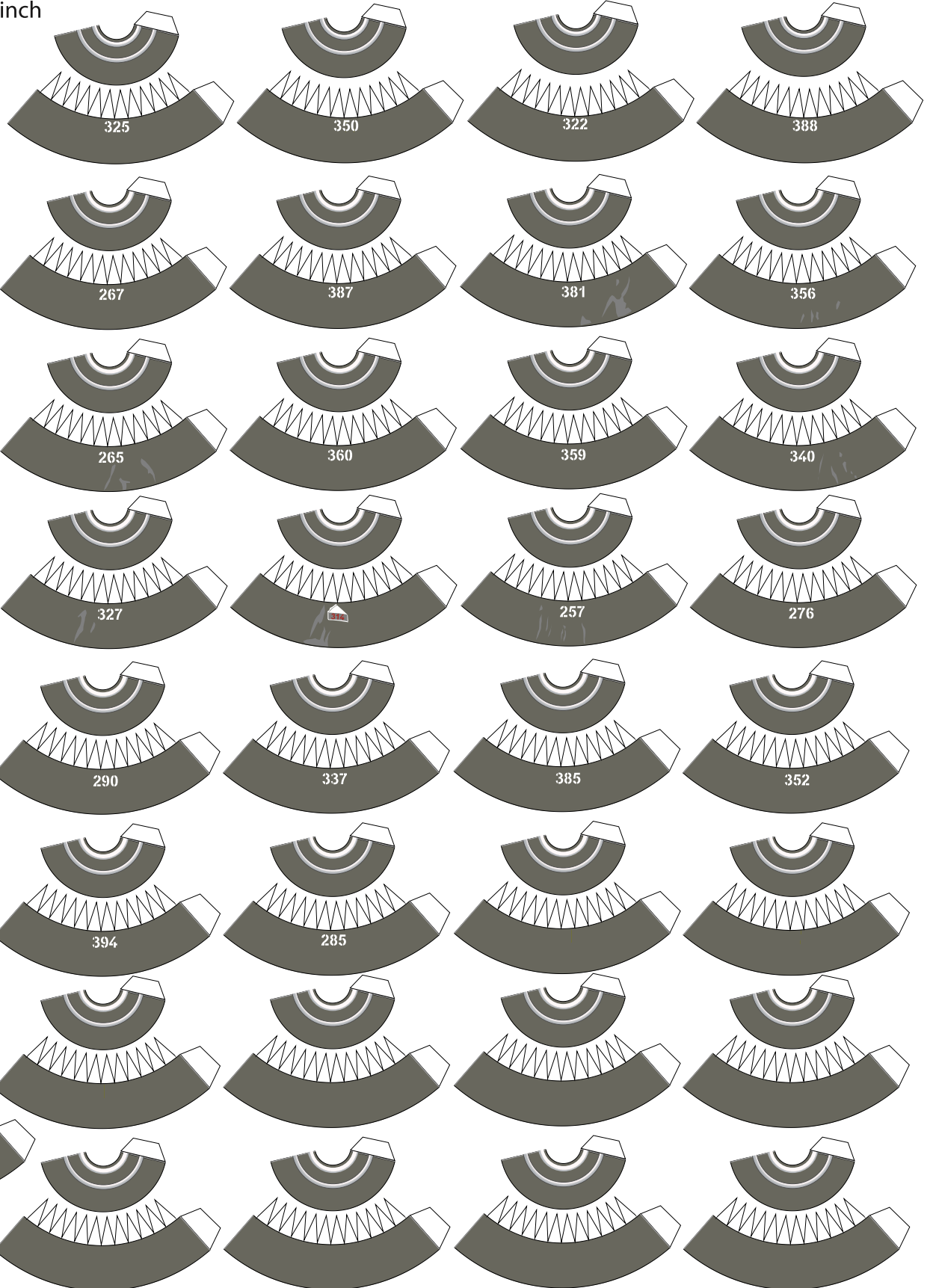



1 cm

1 inch

1:100 Scale

SuperHeavy Raptors B12

Print on white sticker paper

325

350

322

388

267

387

381

356

265

360

359

340

327



257

276

290

337

385

352

394

285



SuperHeavy Raptors BACKPRINT

Print on Cardstock (110 lbs)

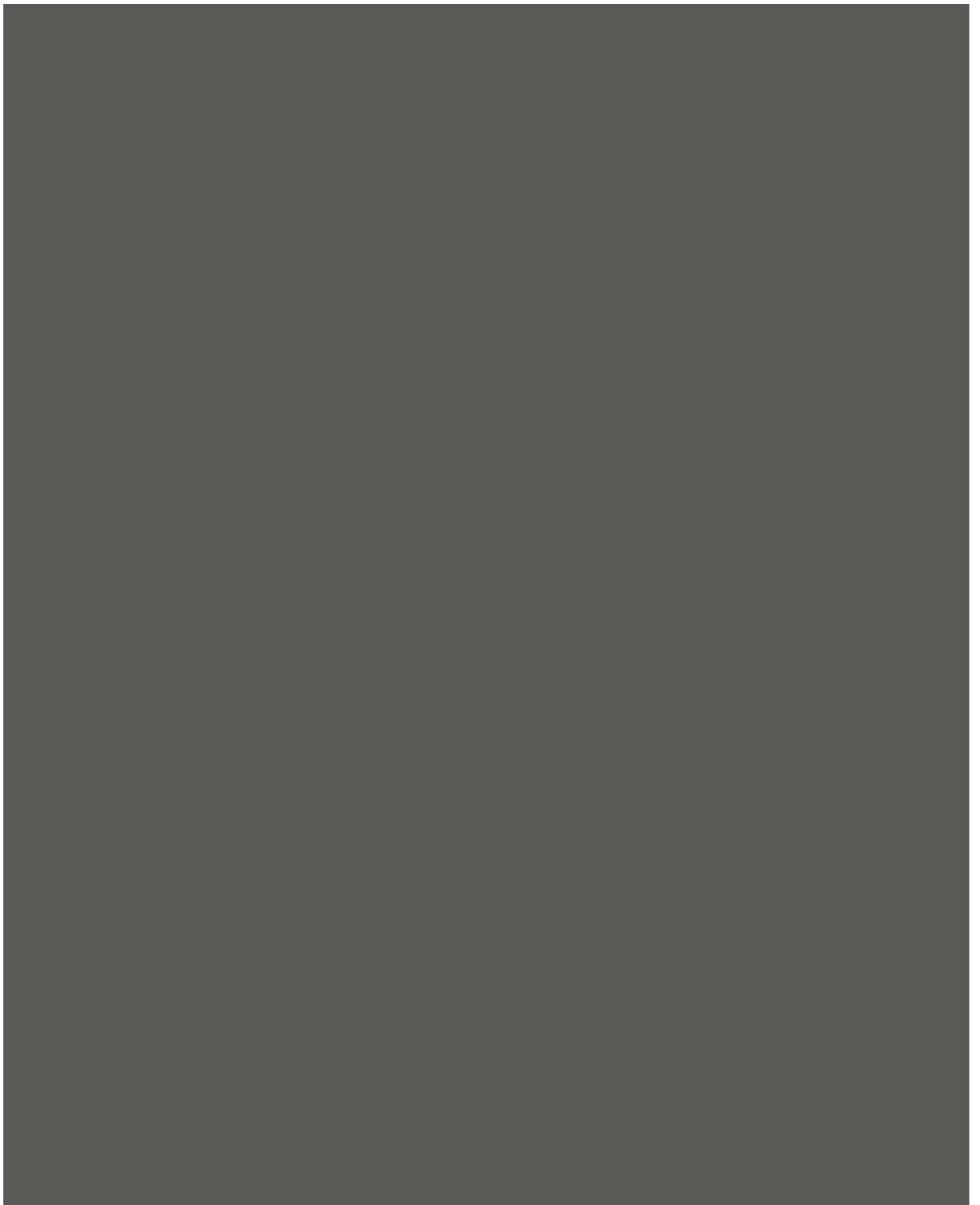



1 cm

1 inch

1:100 Scale

SpaceX Heavy Booster 12

Raptor location

Umbilical side

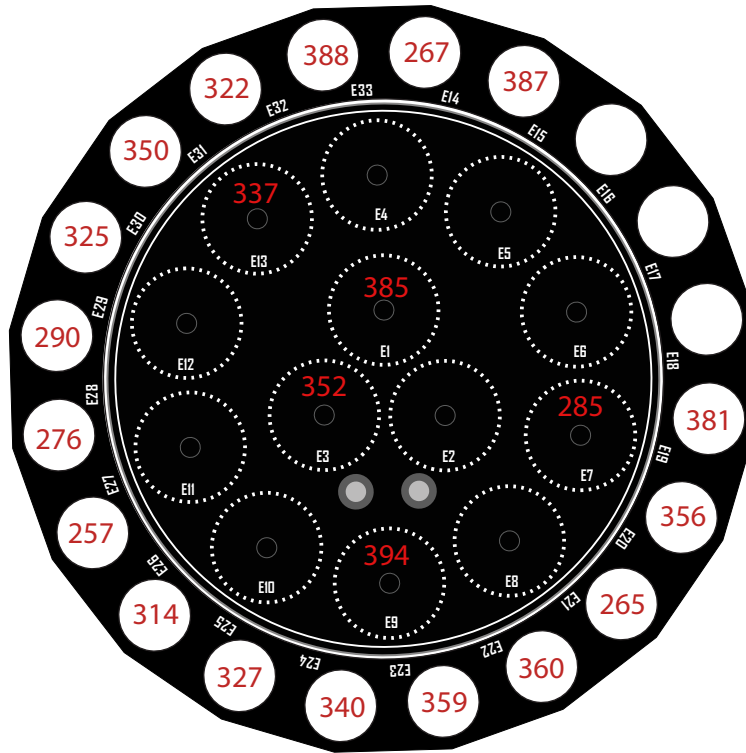

Reference data from Nick (Ring Watchers)



1:100 Scale

Booster 12

Print on Cardstock (110 lbs)
Belly side middle

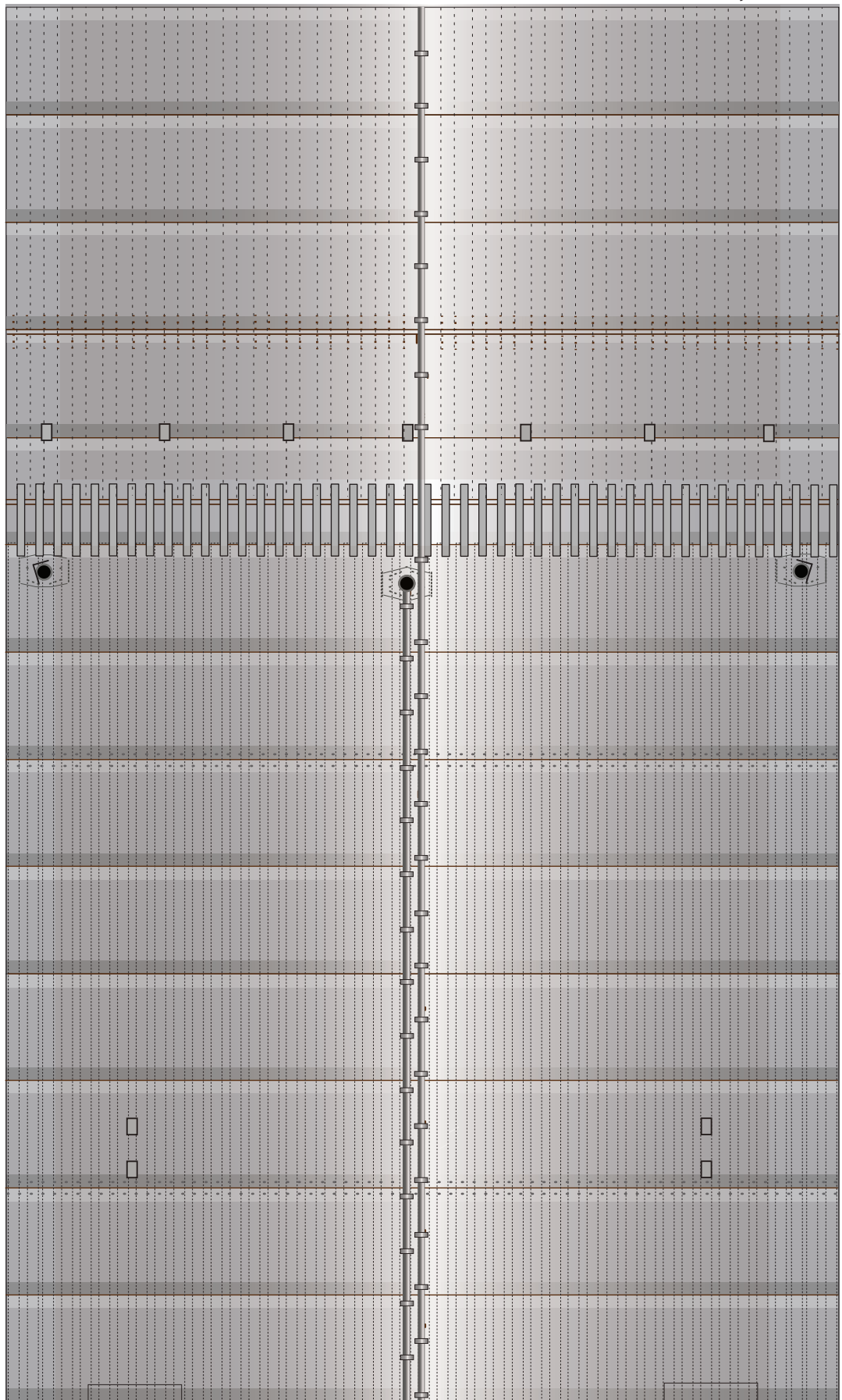
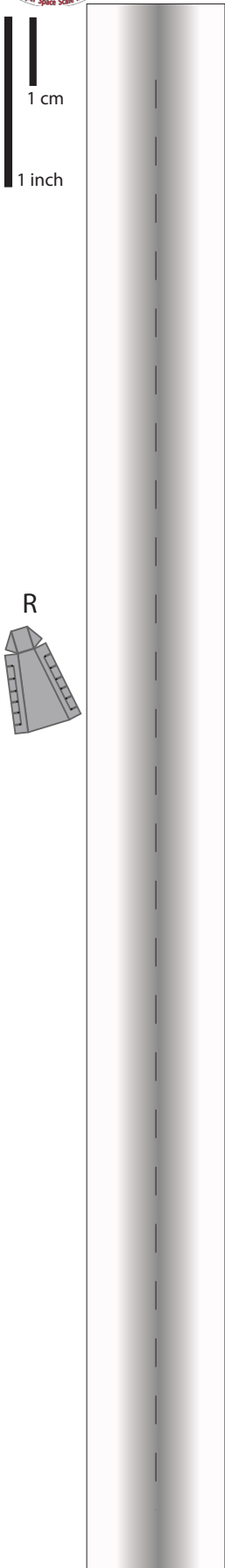



1:100 Scale

Booster 12

Print on Cardstock (110 lbs)
Back side middle

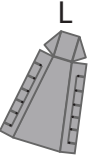
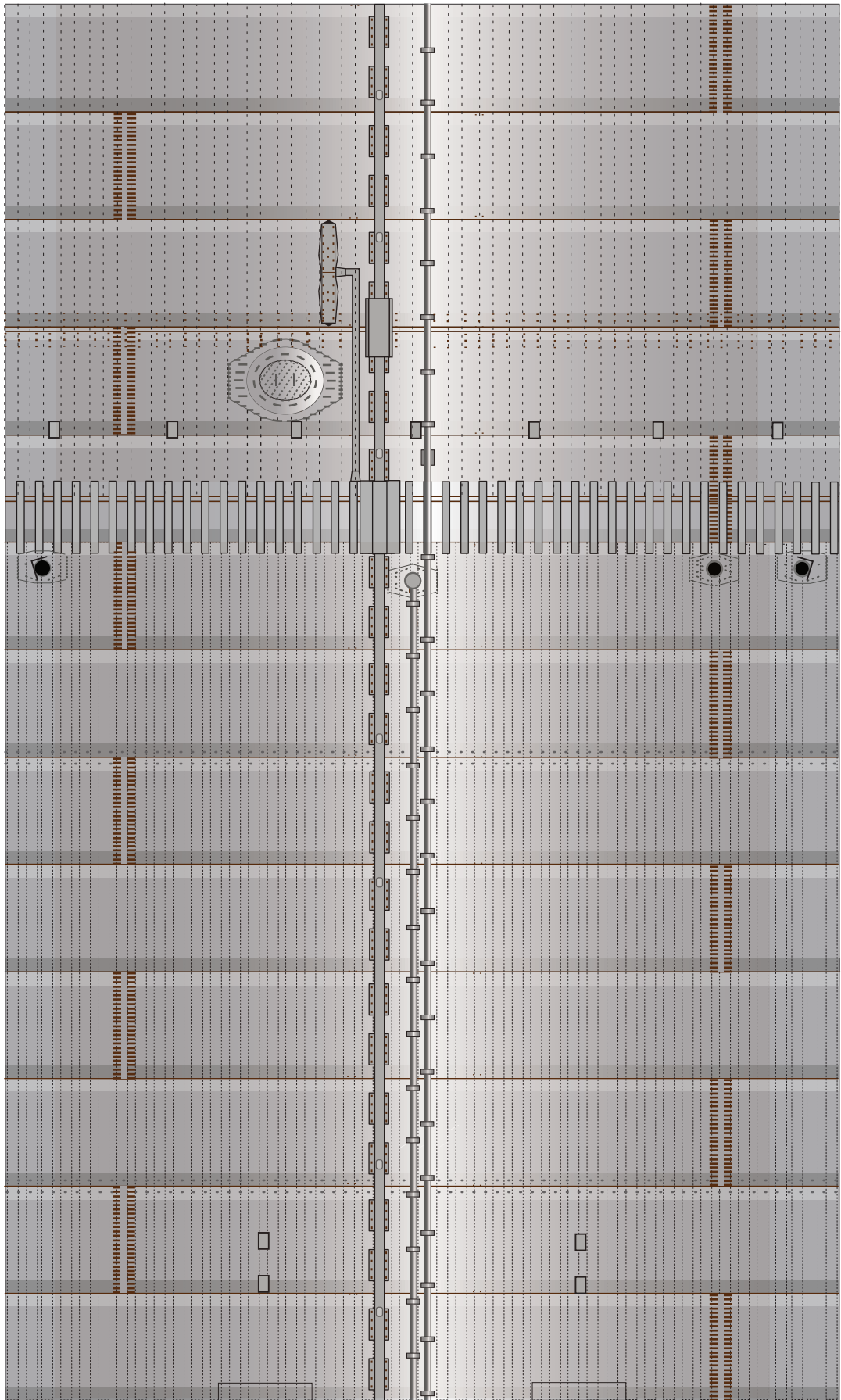
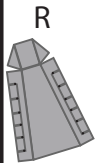



1:100 Scale

Booster 12

Print on Cardstock (110 lbs)
Back side bottom

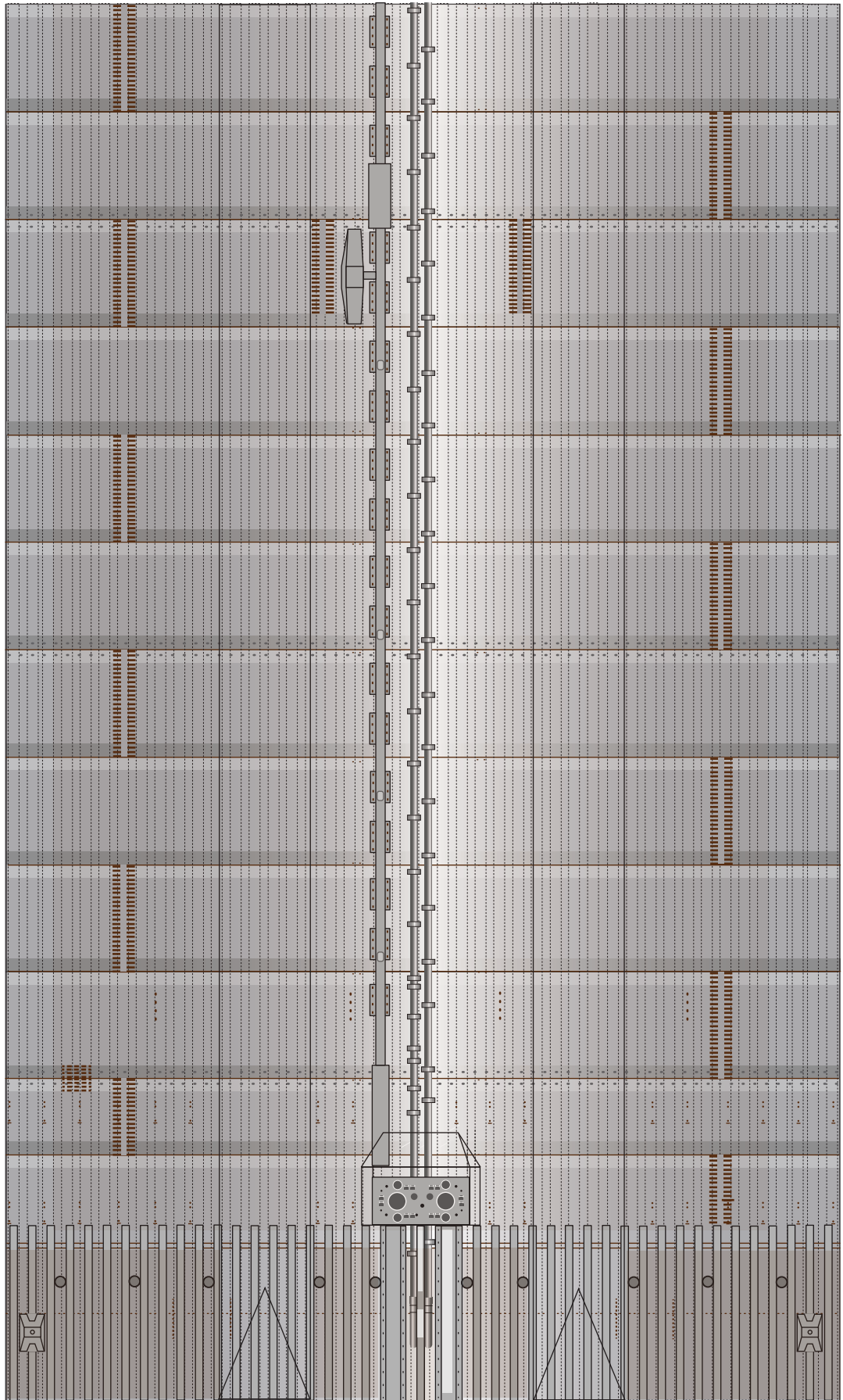
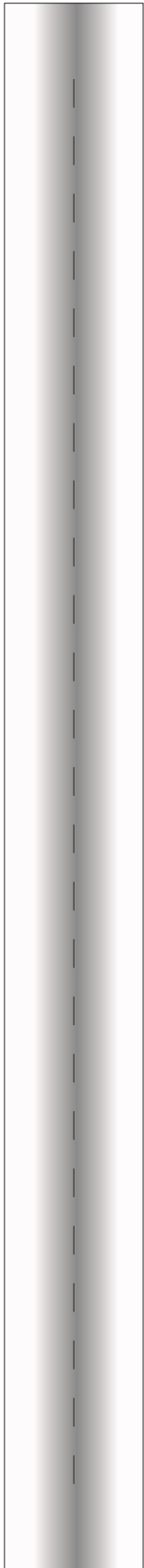



1:100 Scale

Booster 12

Print on Cardstock (110 lbs)
Belly side bottom

