

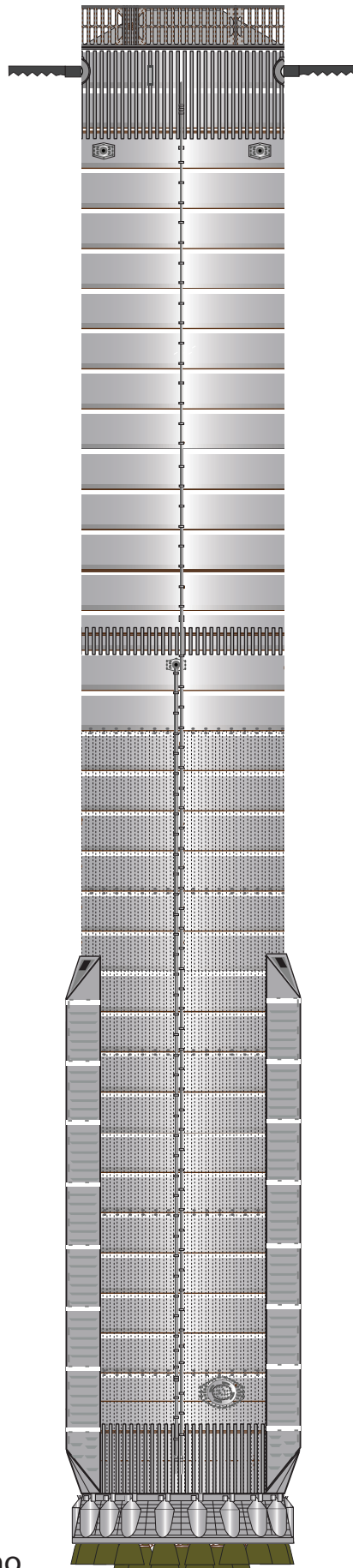

1:100 Scale

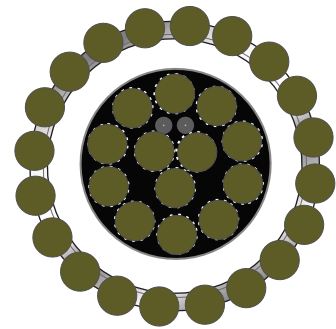

# B13

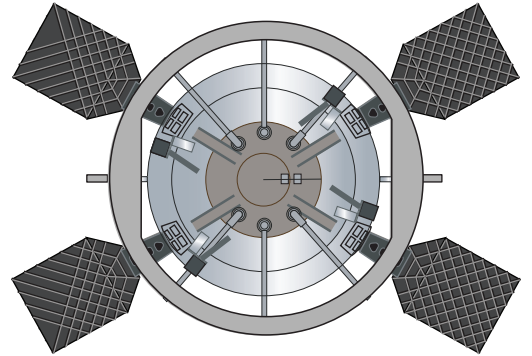
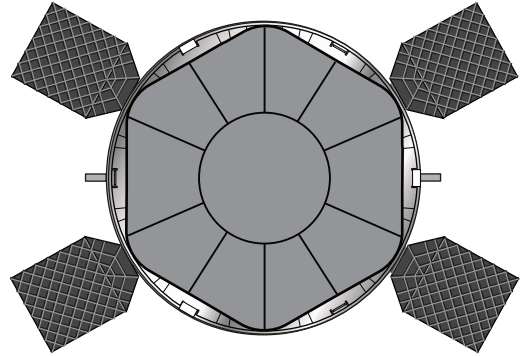

Designed by Alfonso X Moreno

©2024 Not for commercial use



1 cm

1 inch

1:100 Scale

# Hot staging Ring

Print on Cardstock ( 110 lbs)

## Top ring

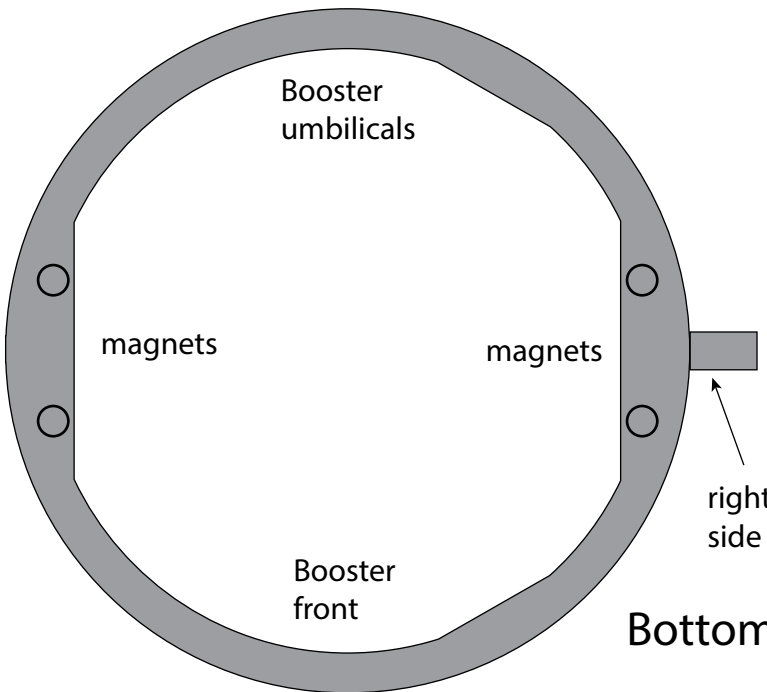
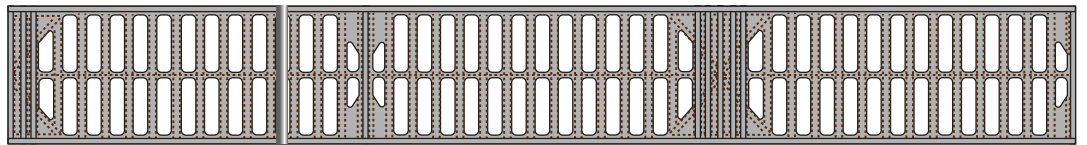
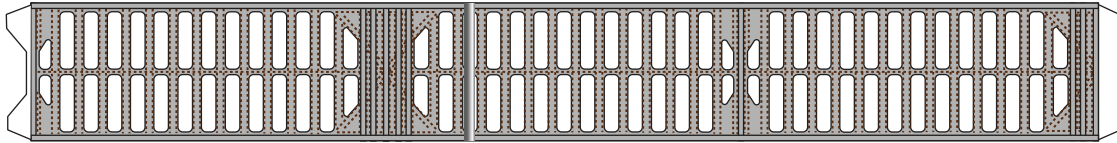
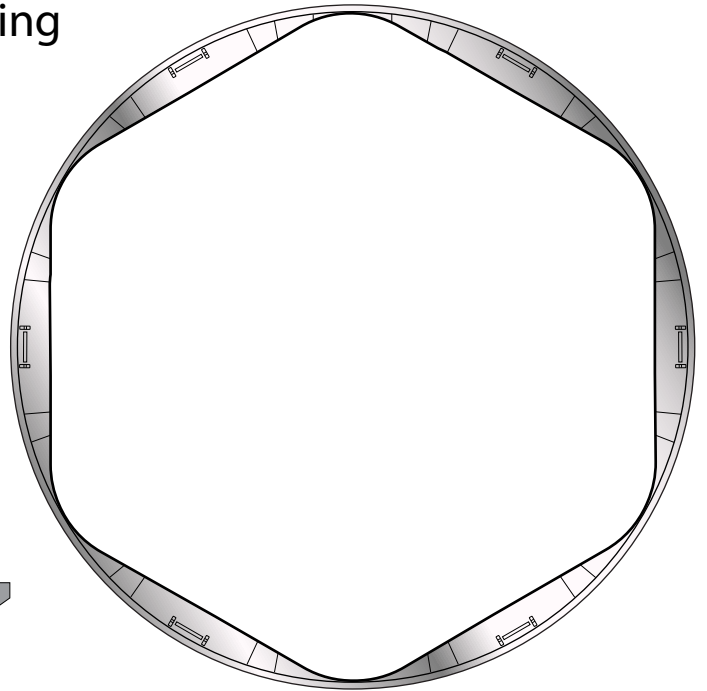
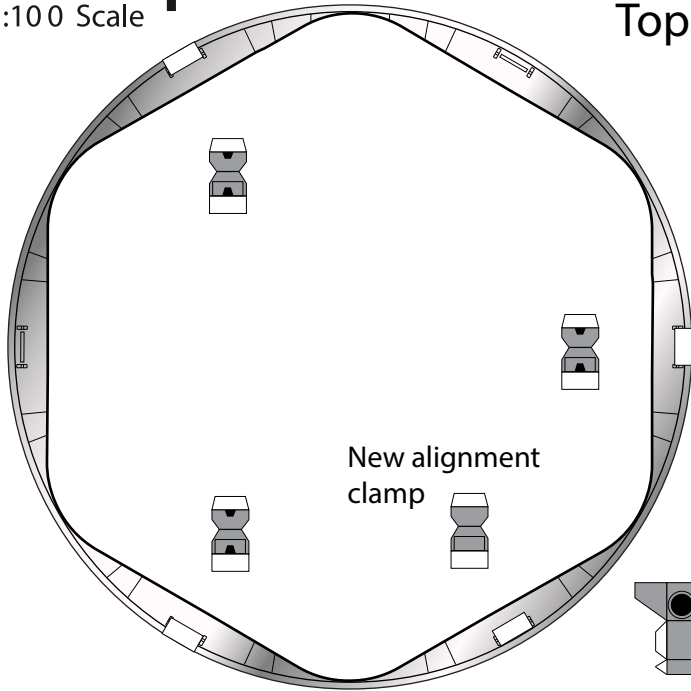

## Bottom ring

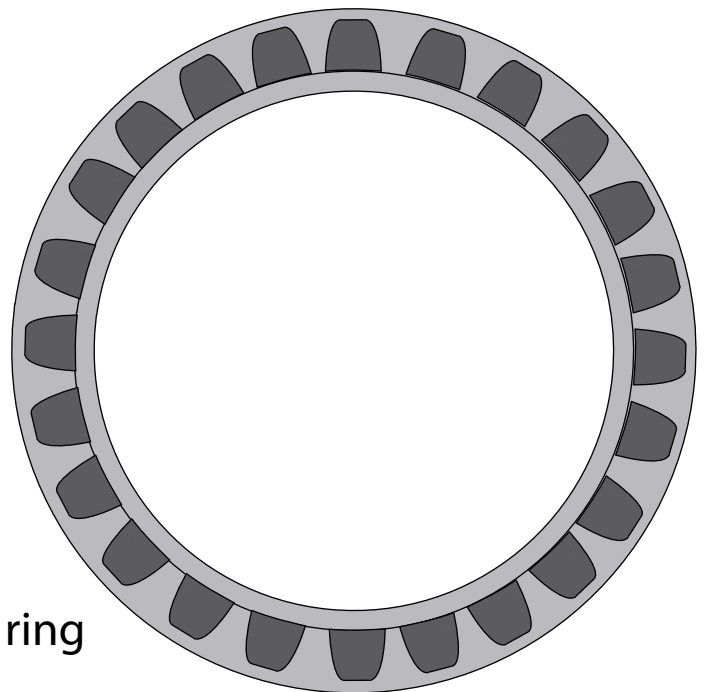



1:100 Scale

# Hot staging Ring

Print on Cardstock ( 110 lbs)

## Back Print

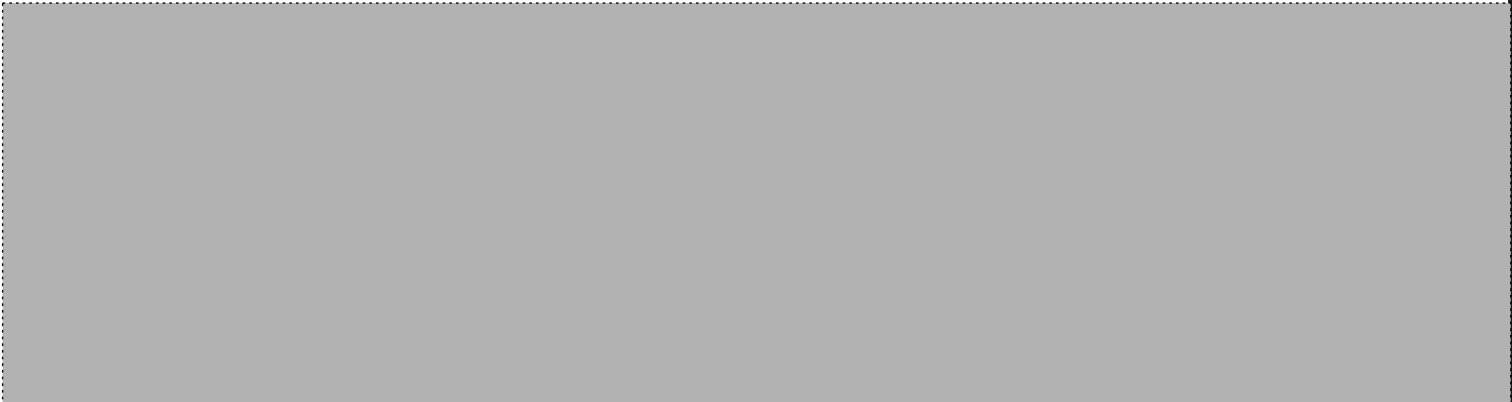



1 cm

1 inch

1:100 Scale

# Hot staging Ring

Print on Cardstock ( 110 lbs)

## Simple version

### Exterior skin

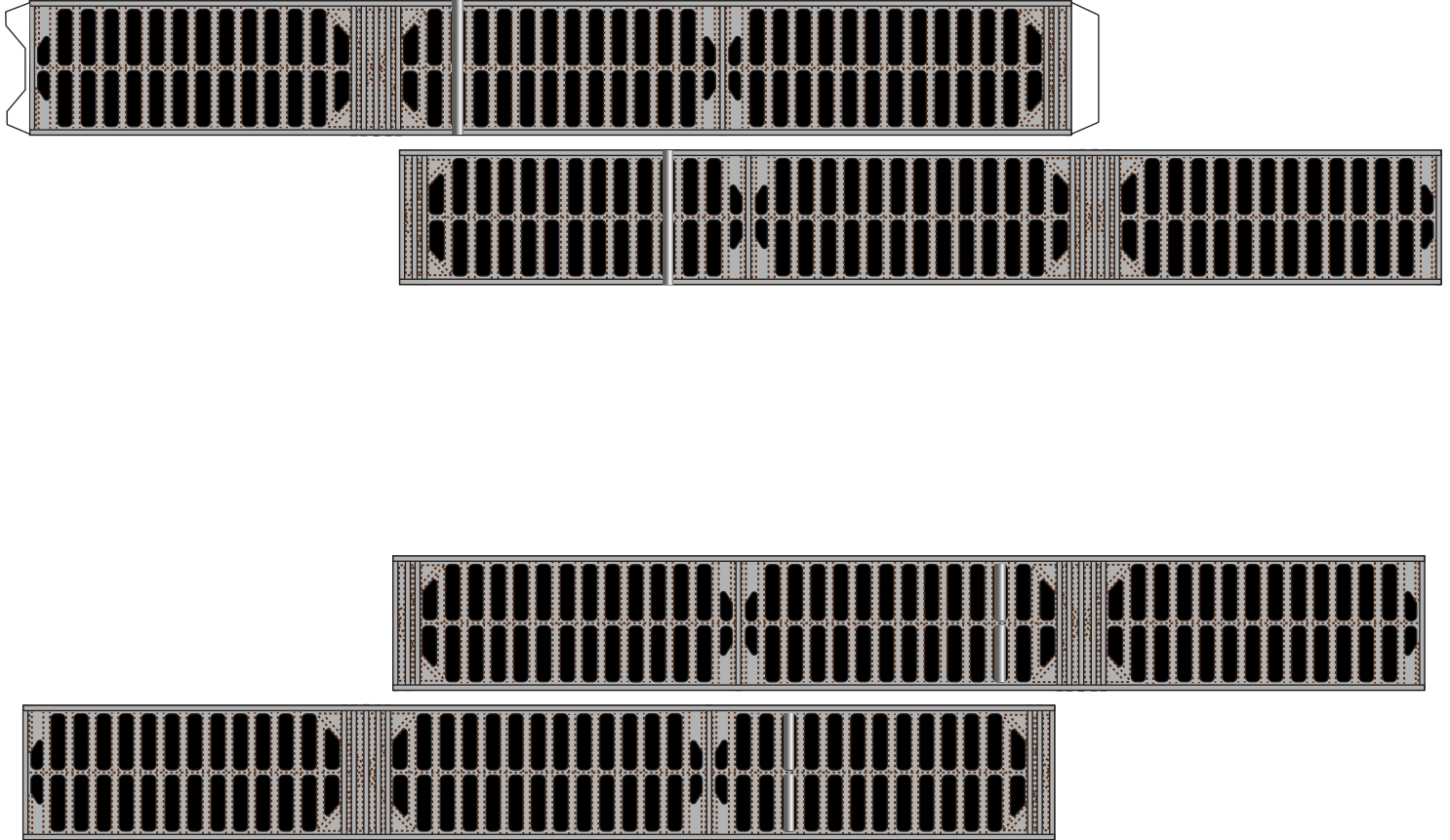

### Interior skin



1 cm

1 inch

1:100 Scale

# Hot staging Ring Dome

Print on Cardstock ( 110 lbs)

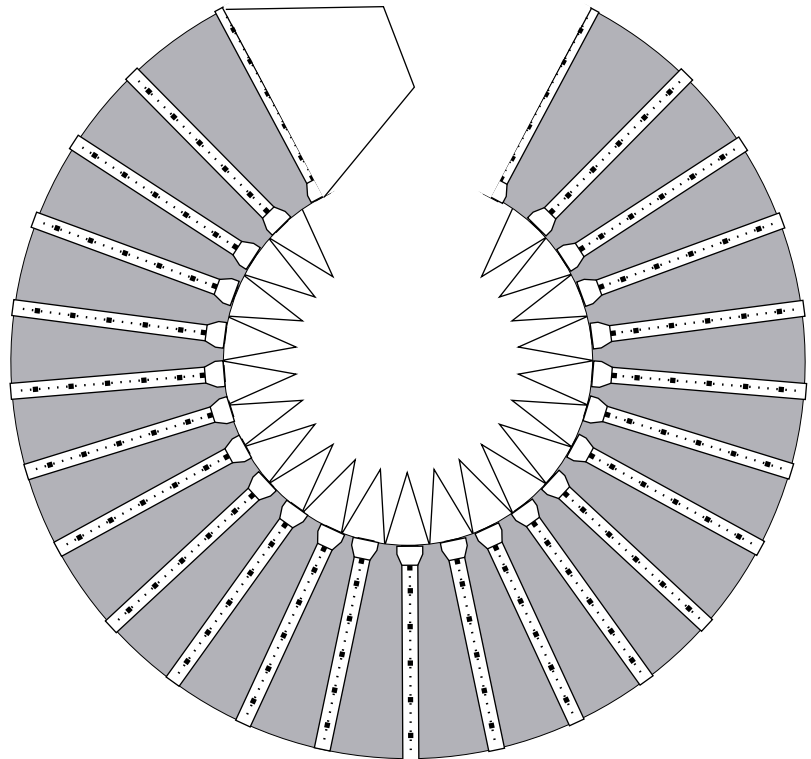
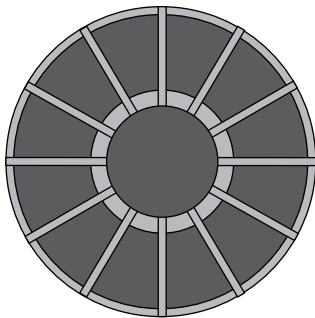
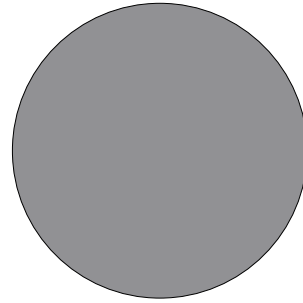
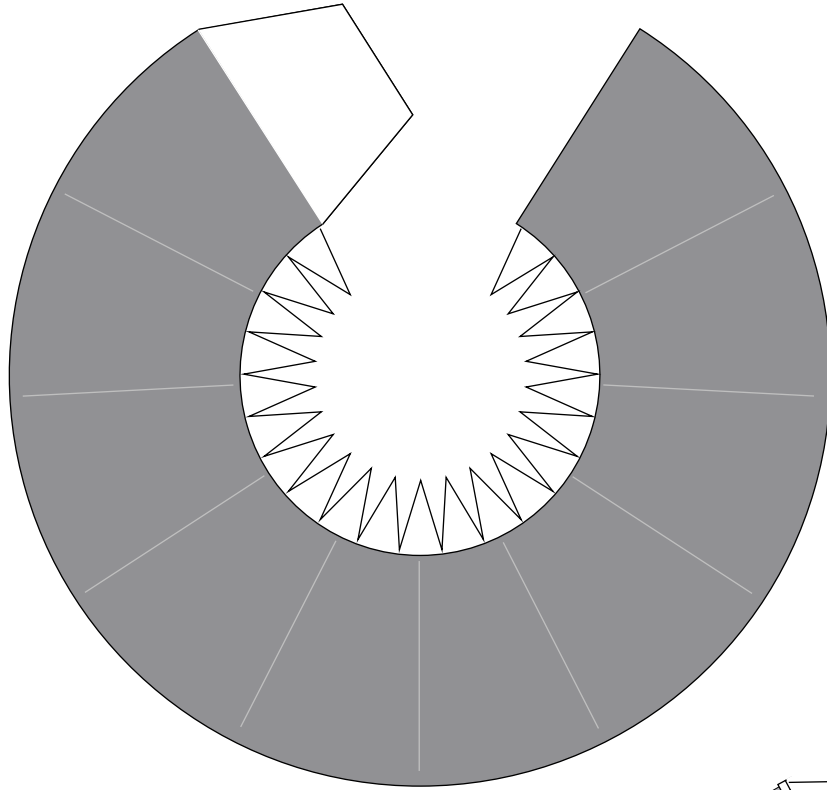



# SpaceX SuperHeavy

Print on Cardstock ( 110 lbs)

1:100 Scale

## Top ring

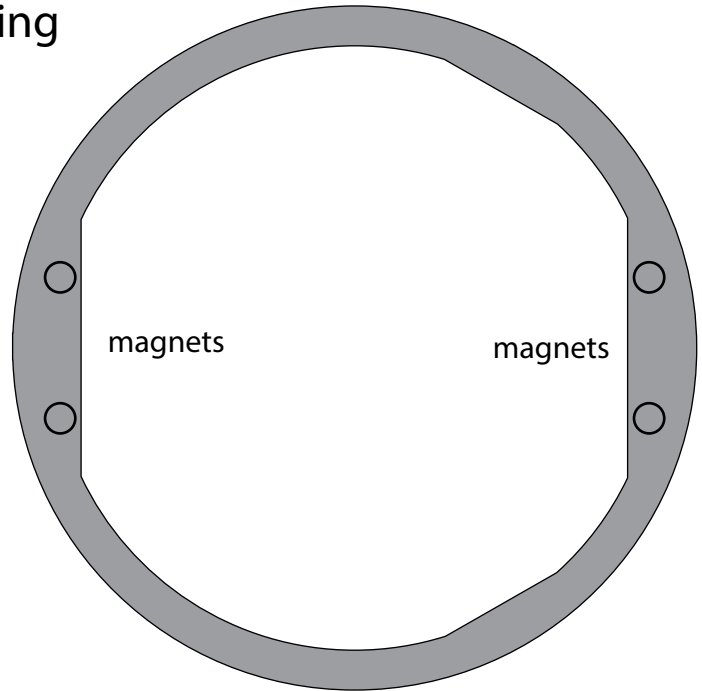
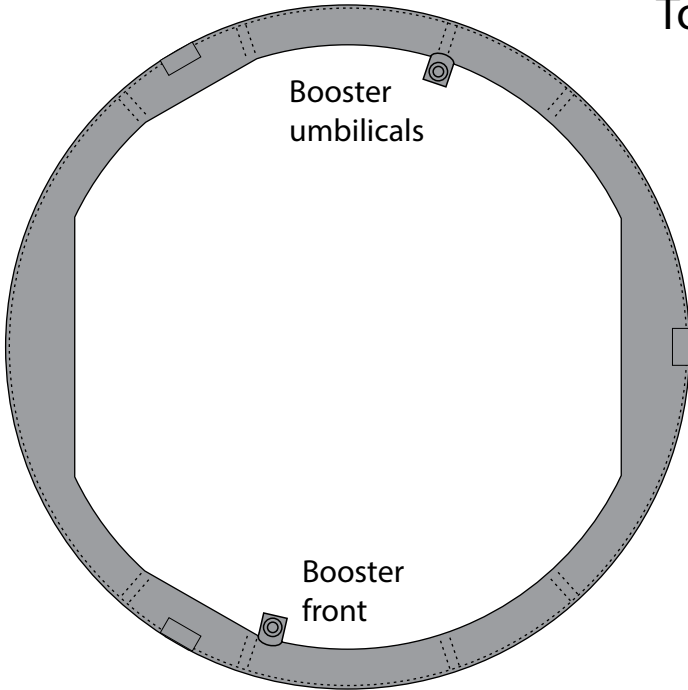

right side

## Bottom ring

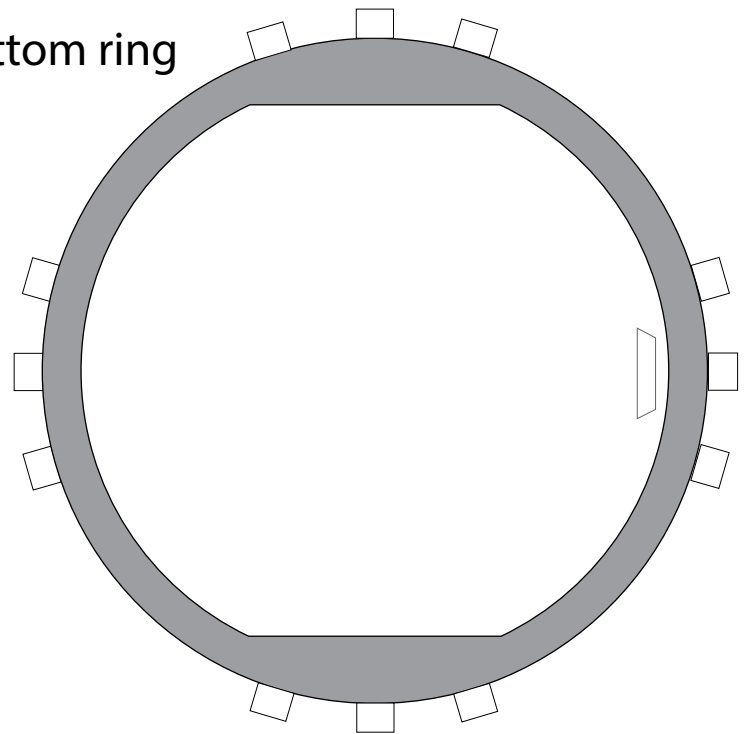
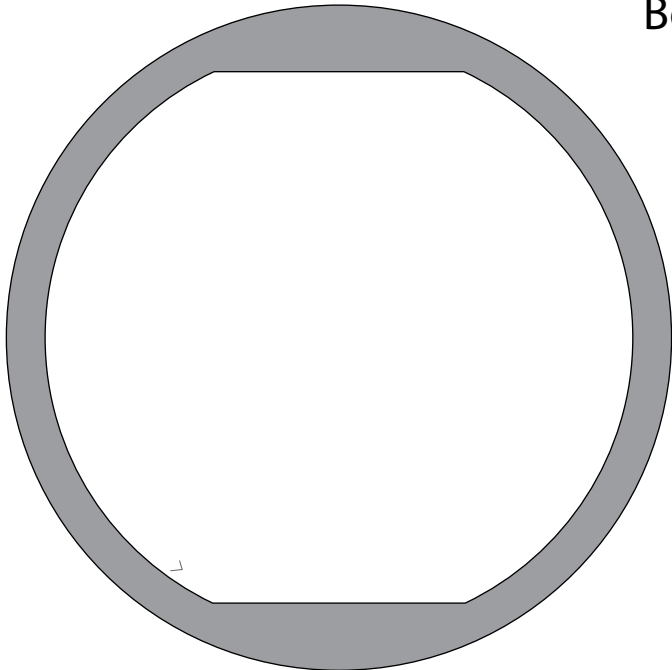



1 cm

1 inch

1:100 Scale

# SuperHeavy B13 Upper Dome

Print on Cardstock (110 lbs)

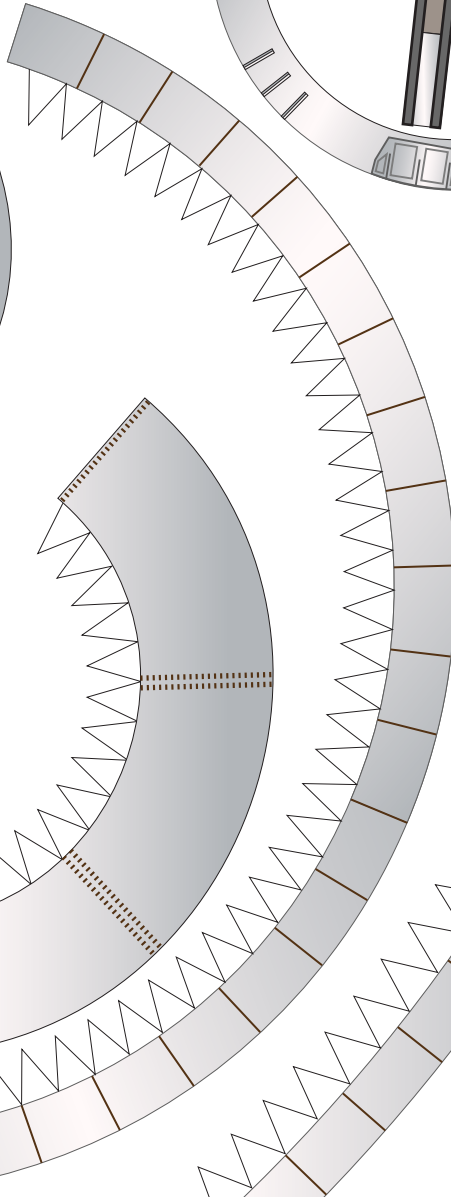
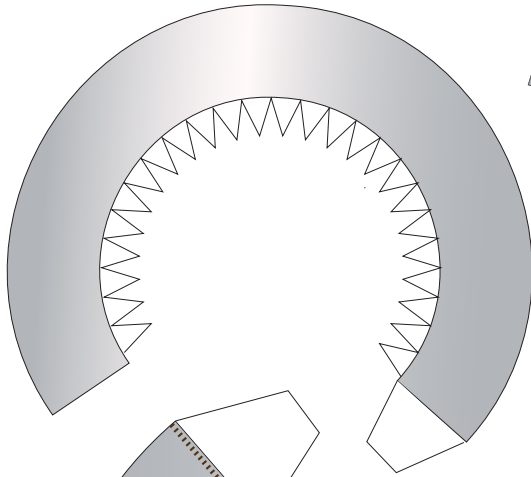
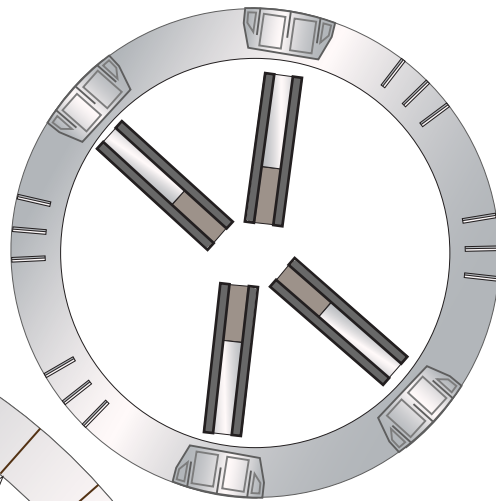
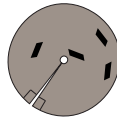
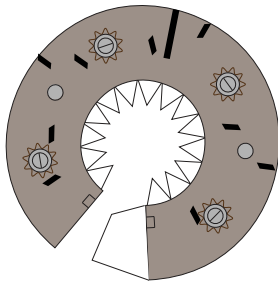

Ch4 vent pipes

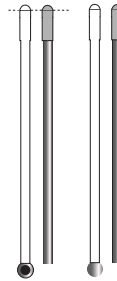

Ch4 vent pipes

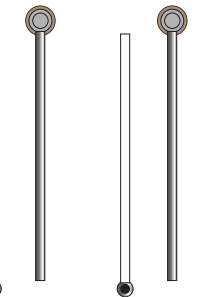
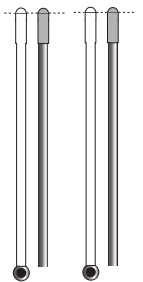

Ch4 press lines

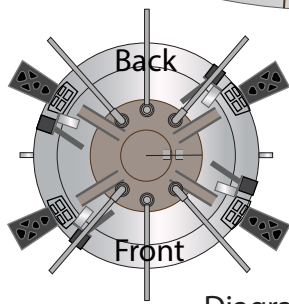
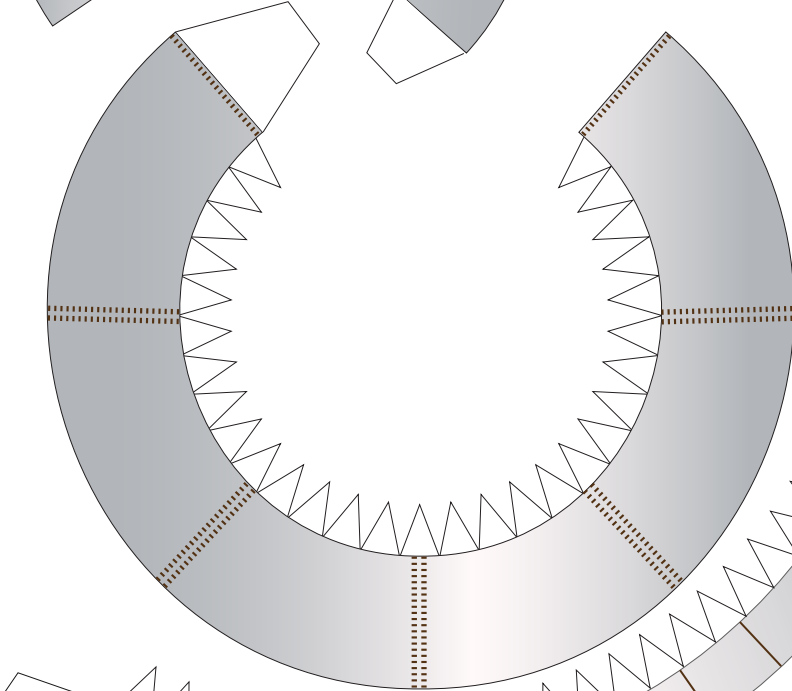

Diagram

Diagram

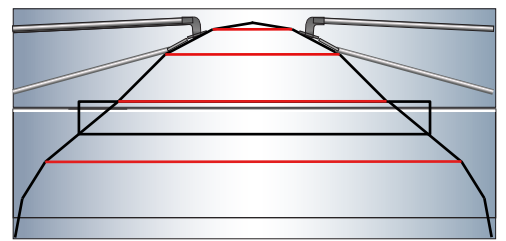



1 cm

1 inch

1:100 Scale

# SpaceX Starship B13

Print on Cardstock (110 lbs)

## Grid Fins servo motors and Connectors

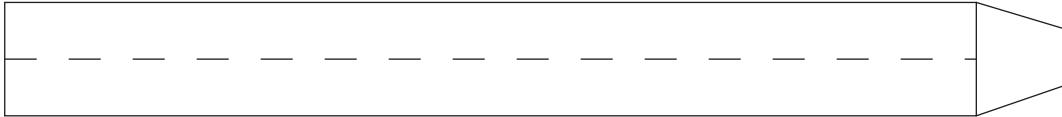
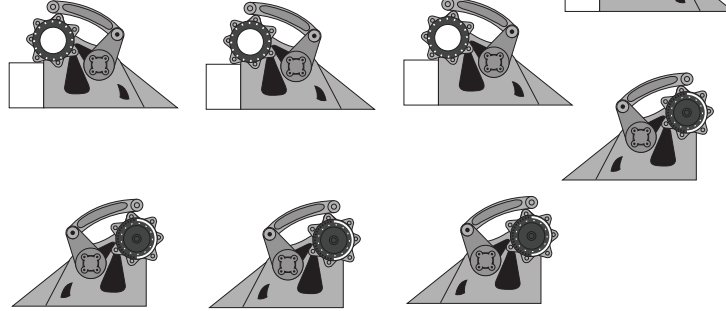
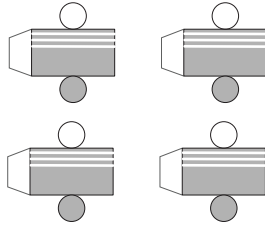
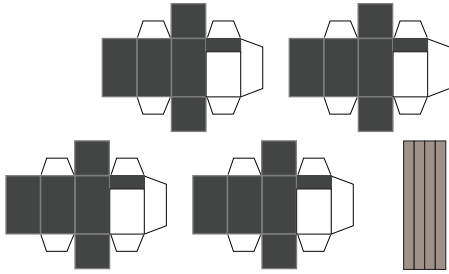

top/middle

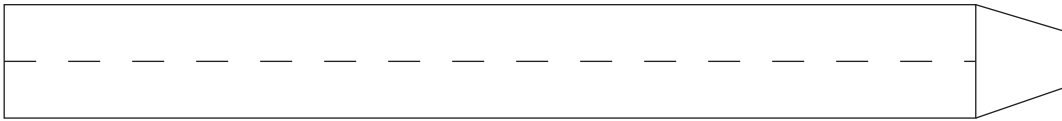
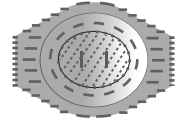
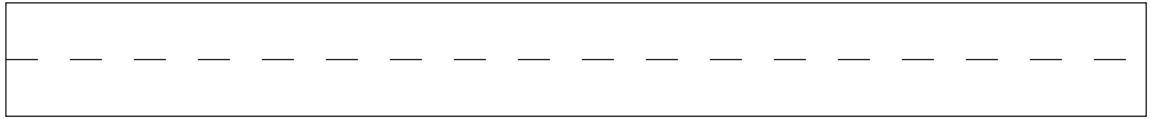

middle/bottom

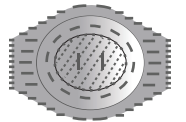

Glue tip of the  
Ch4 press line to  
cover the black circles

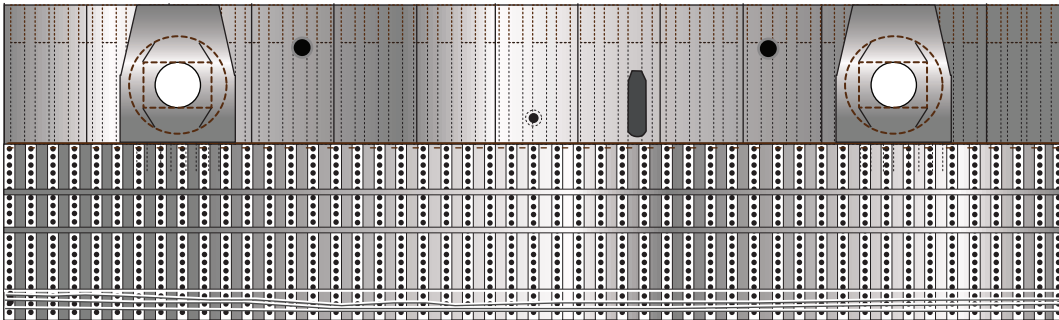
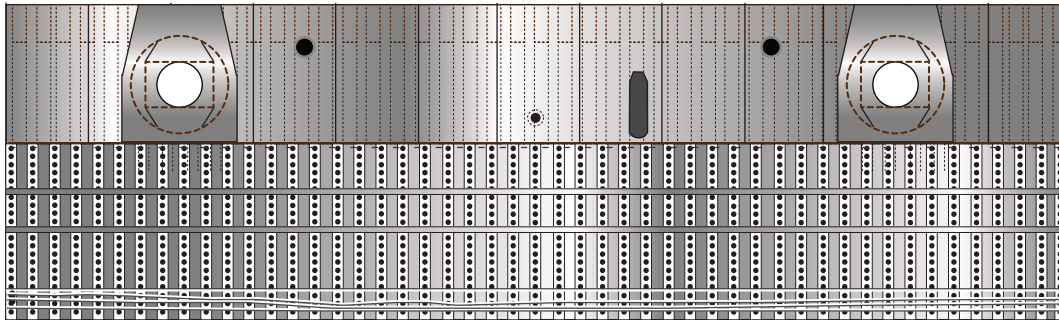

Interior wall  
for upper dome  
section





1 cm

1 inch

1:100 Scale

# SuperHeavy **B13** Grid Fins

Print on Cardstock ( 110 lbs)

## Simple version

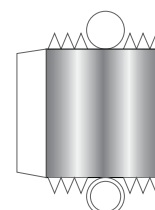
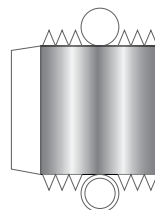
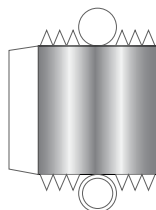
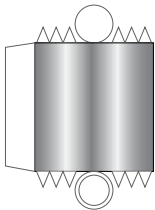
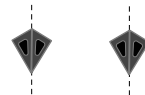
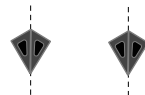
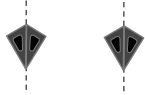
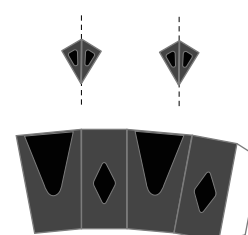
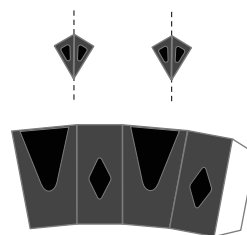
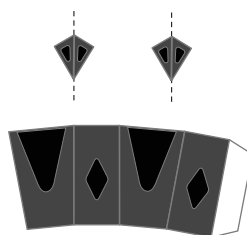
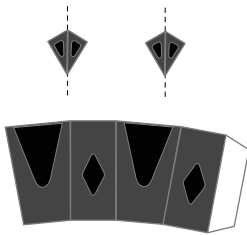
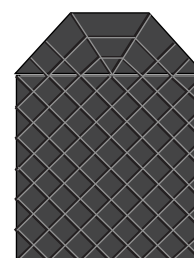
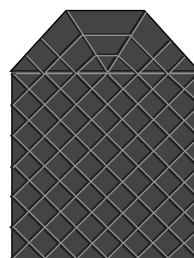
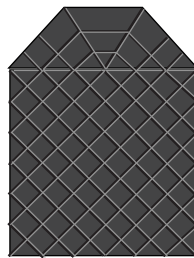
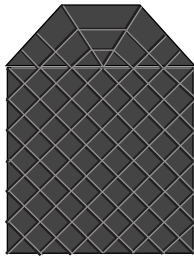
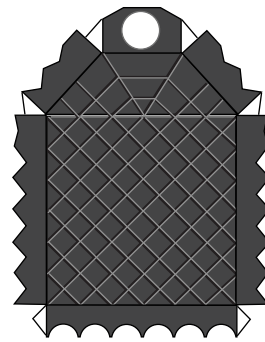
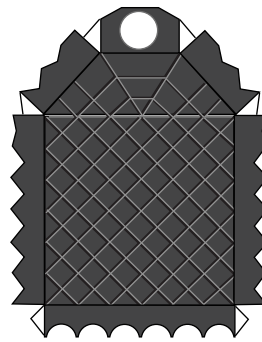
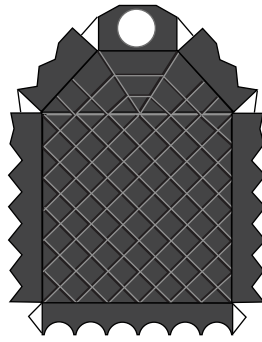
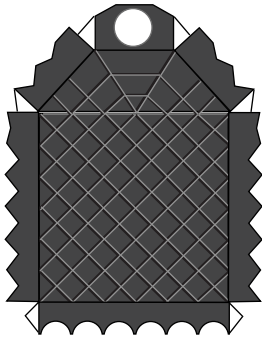



# B13 Grid Fins

Print on Cardstock ( 110 lbs)

## Back Print

1:100 Scale





1 cm

1 inch

1:100 Scale

# SuperHeavy B13 Grid Fins

Print on Cardstock ( 110 lbs)

## Detailed version

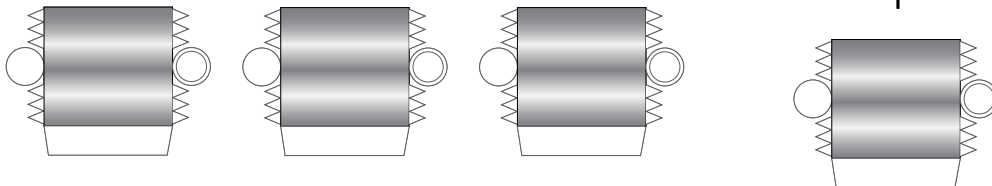
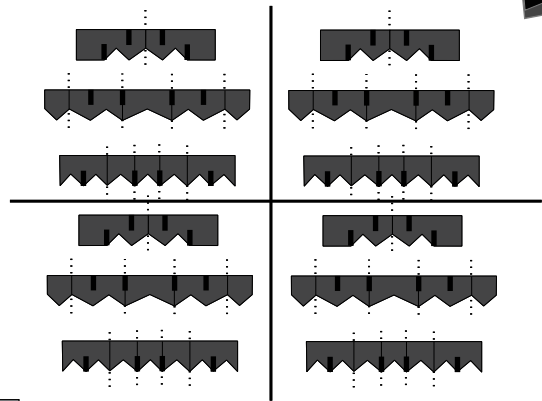
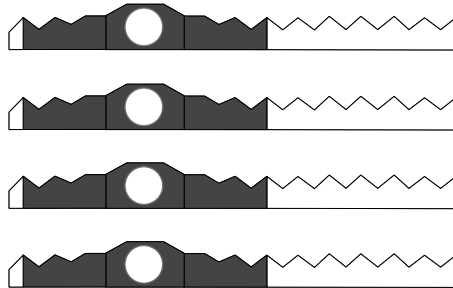
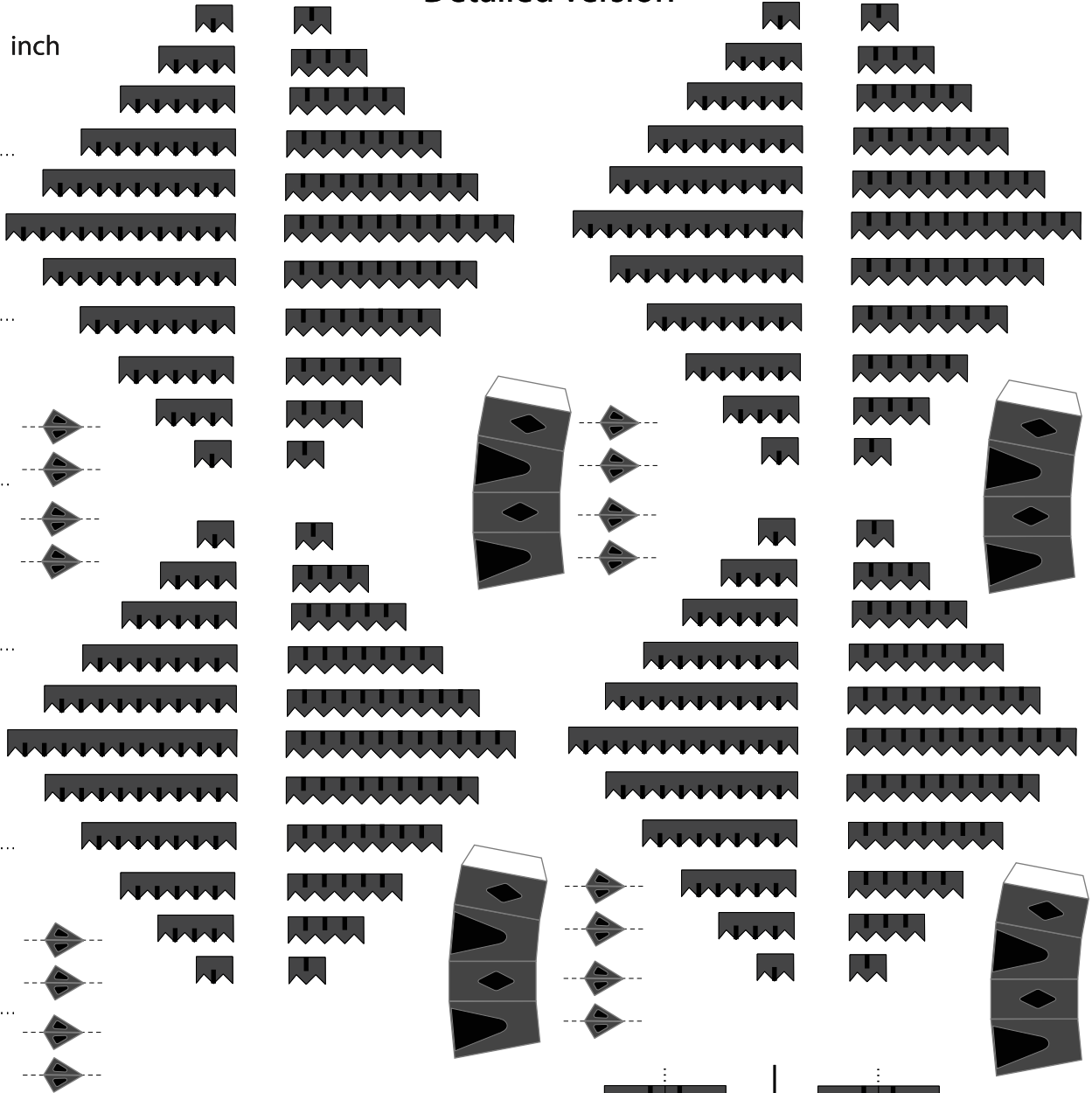
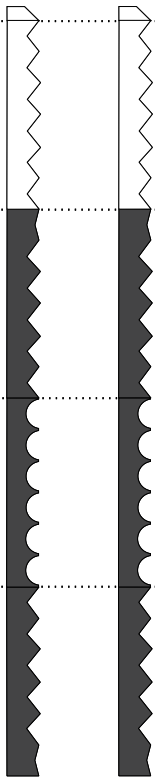



# **B13** Grid Fins back print

Print on Cardstock ( 110 lbs)

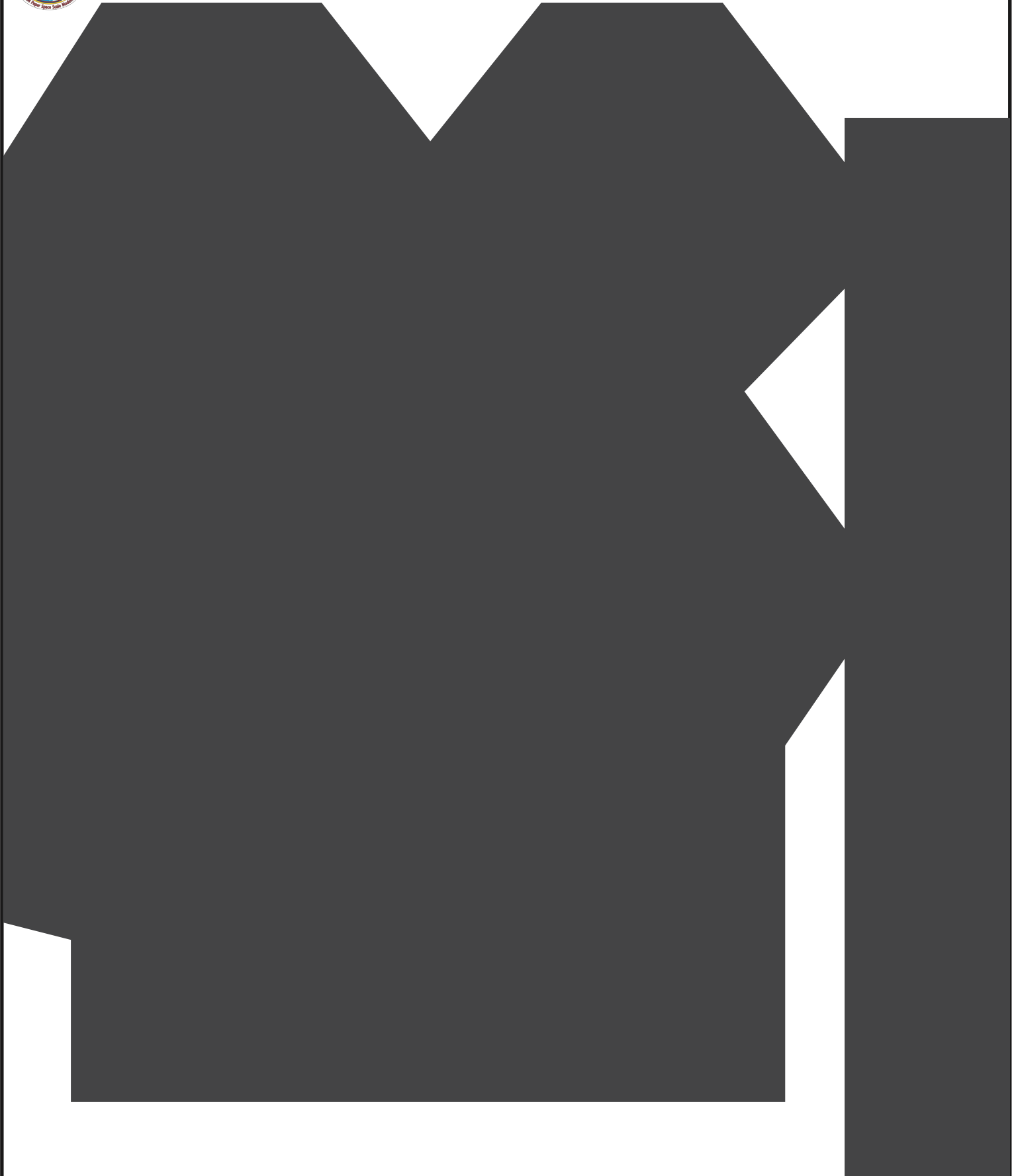



1:100 Scale



# Booster 13

Print on Cardstock (110 lbs)

Belly side top

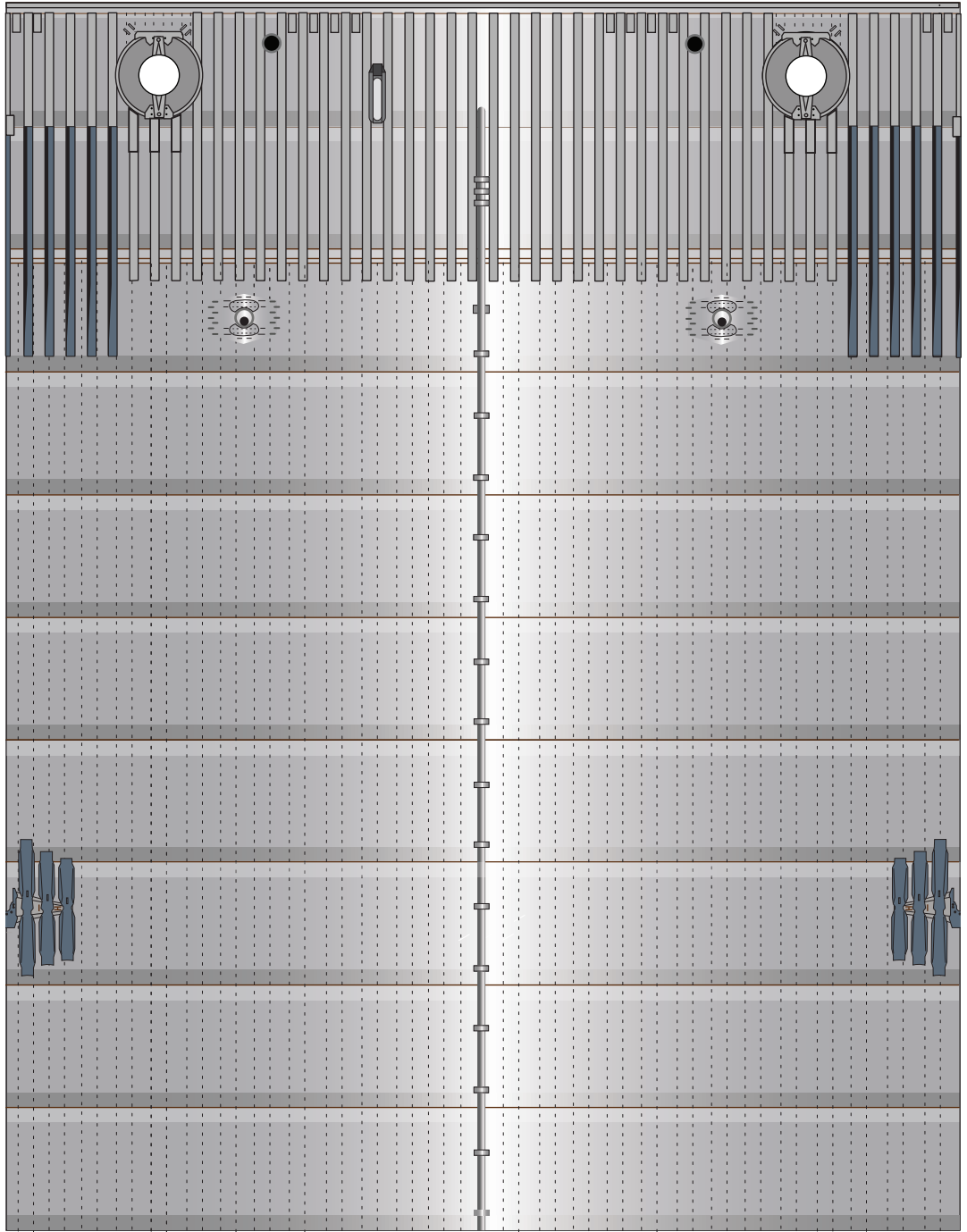
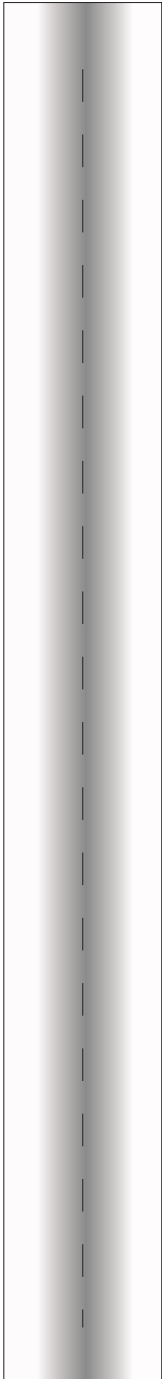
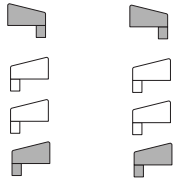



1:100 Scale



# Booster 13

Print on Cardstock (110 lbs)

Back side top

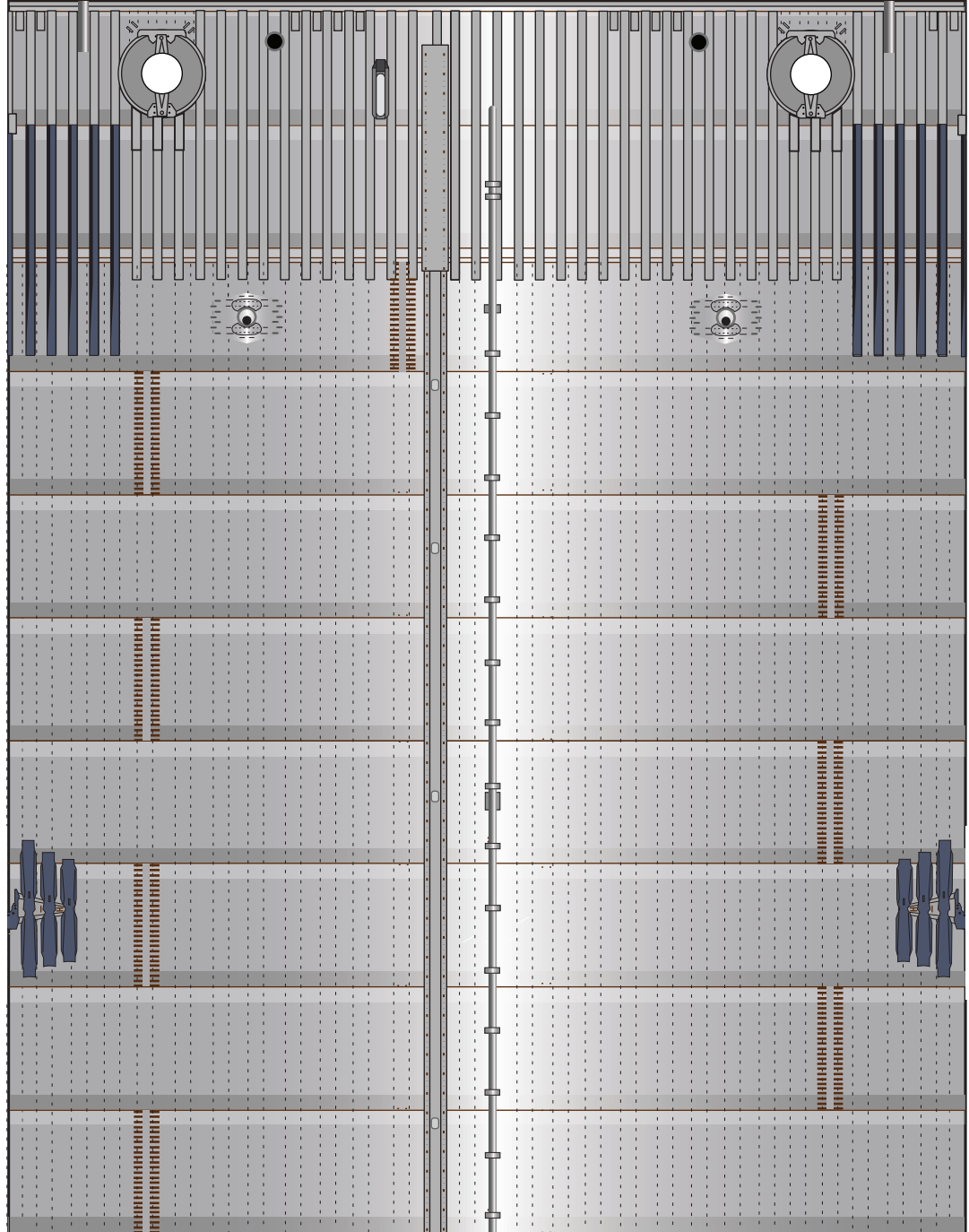
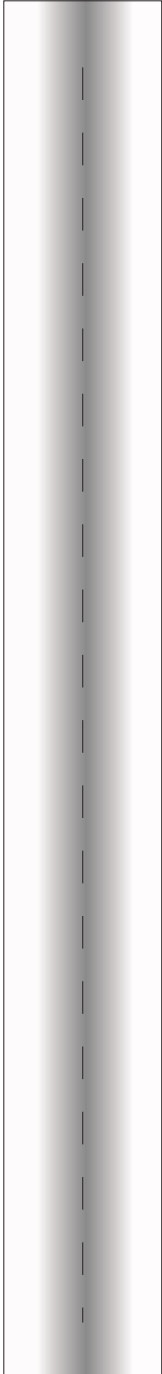



1:100 Scale

# Booster 13

Print on Cardstock (110 lbs)  
Belly side middle

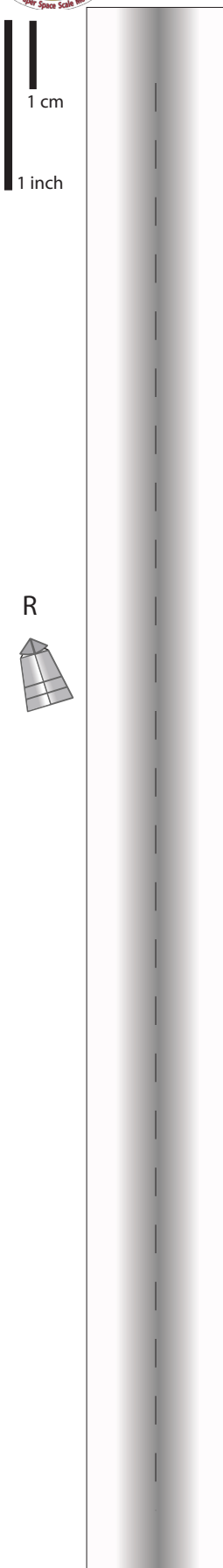

1 cm

1 inch

R

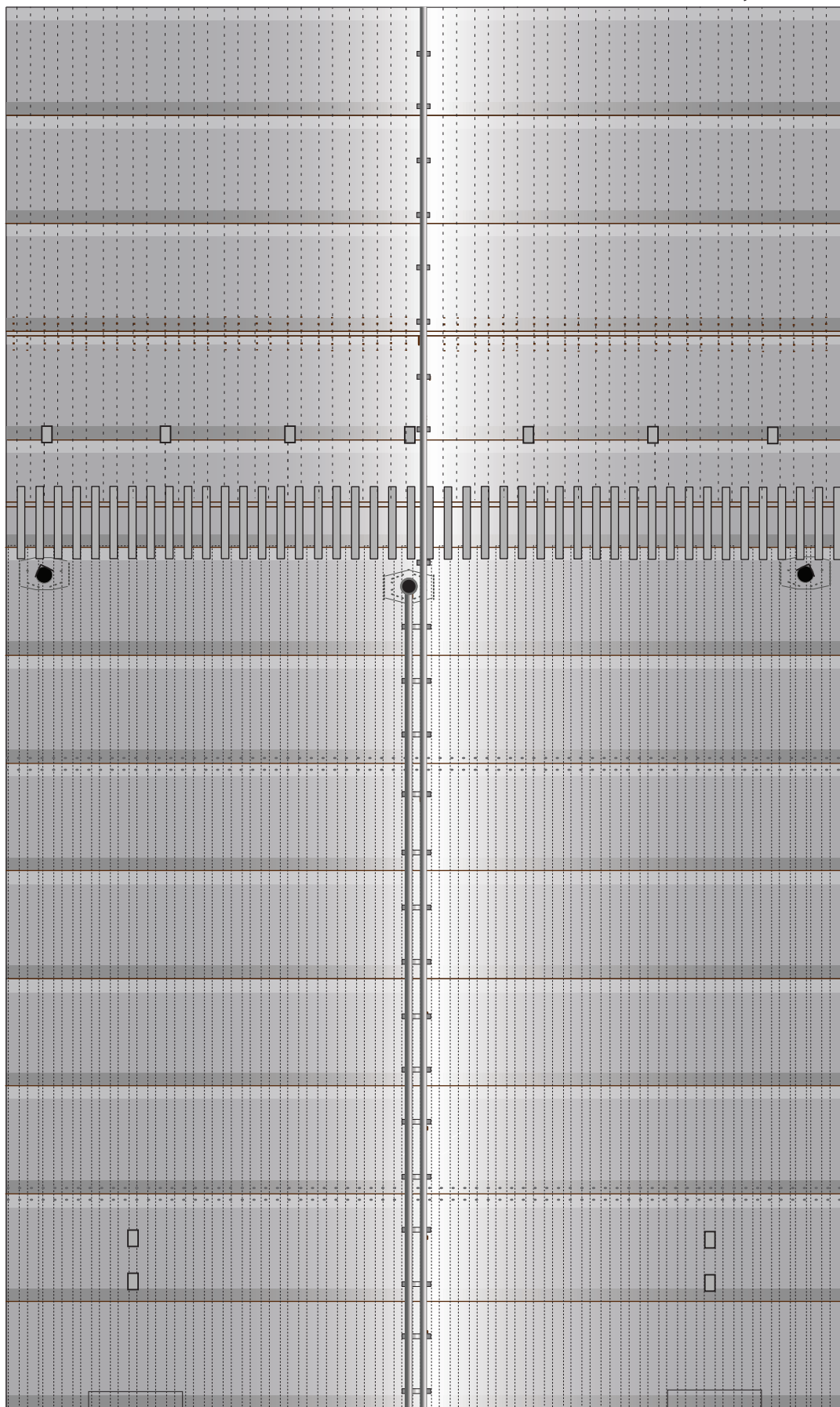

L





1:100 Scale

# Booster 13

Print on Cardstock (110 lbs)  
Back side middle



R



L

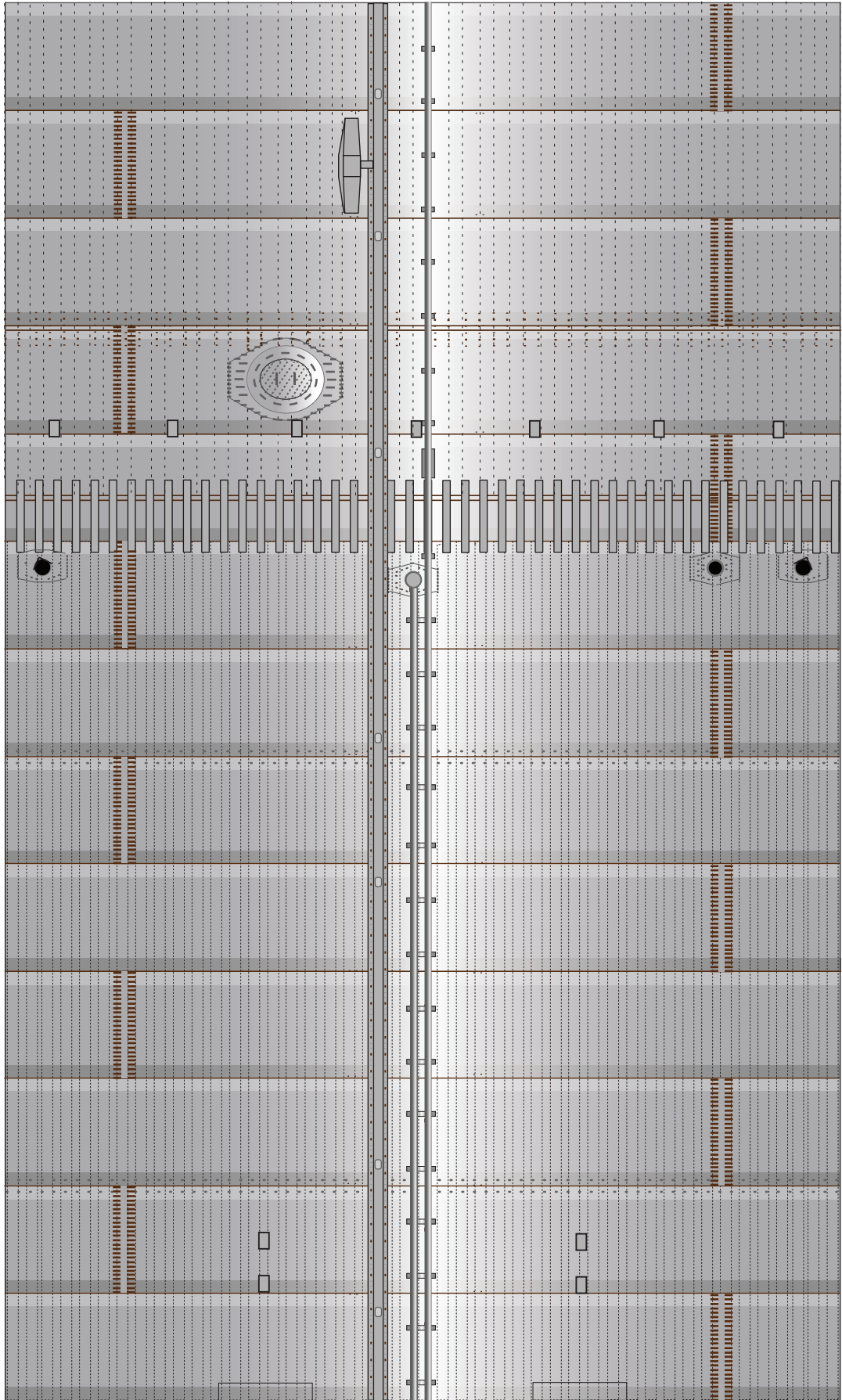





1:100 Scale

# Booster 13

Print on Cardstock (110 lbs)

Belly side bottom

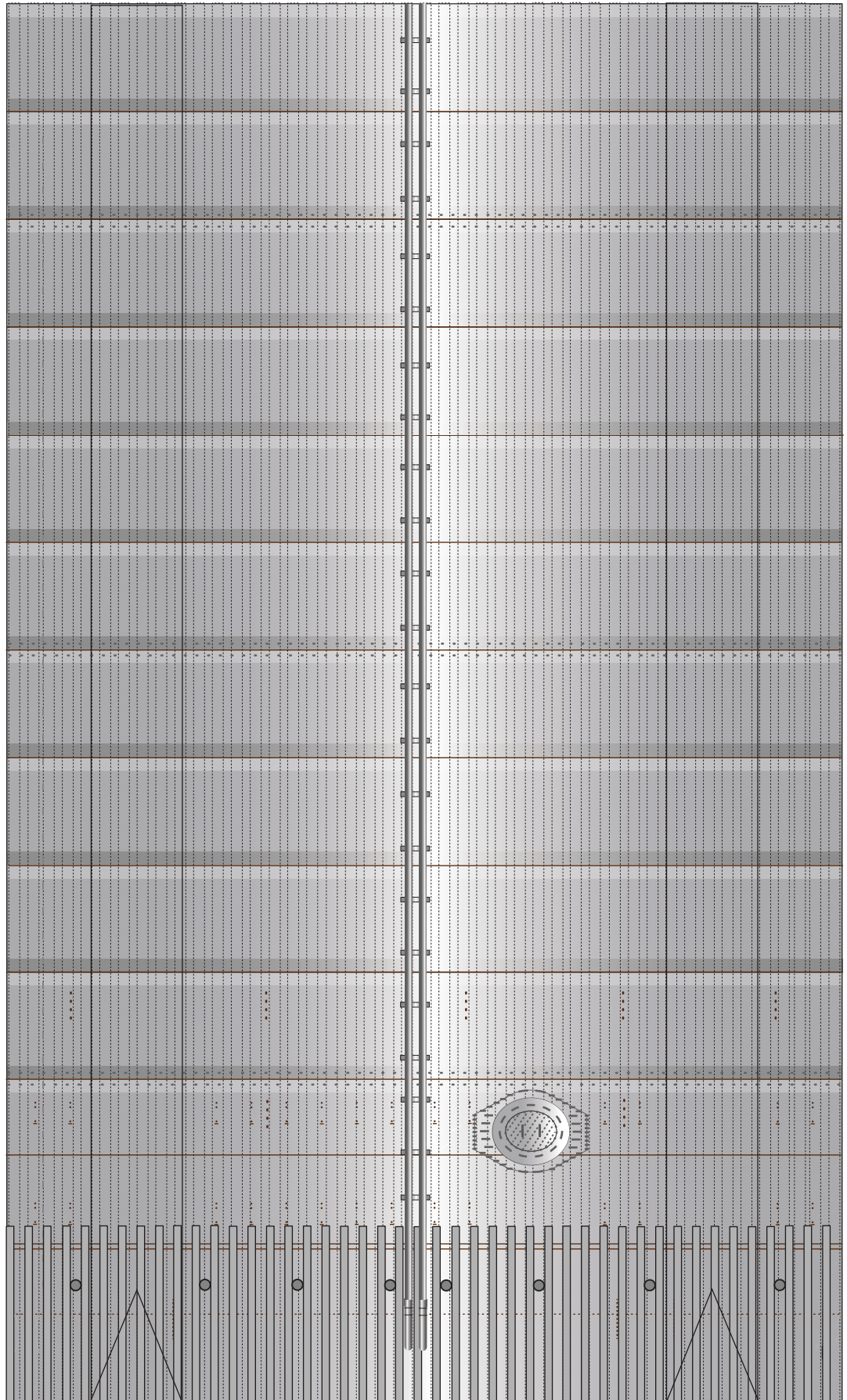
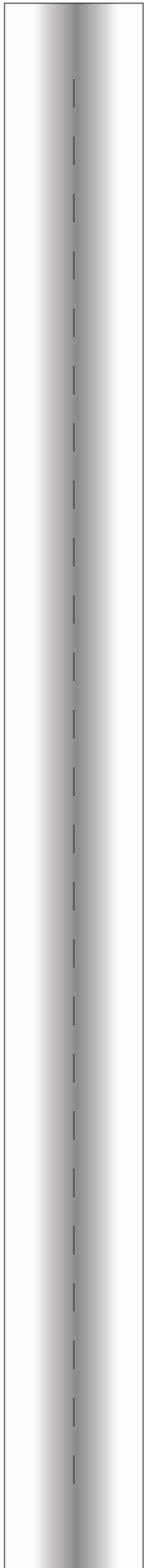



1:100 Scale

# Booster 13

Print on Cardstock (110 lbs)  
Back side bottom

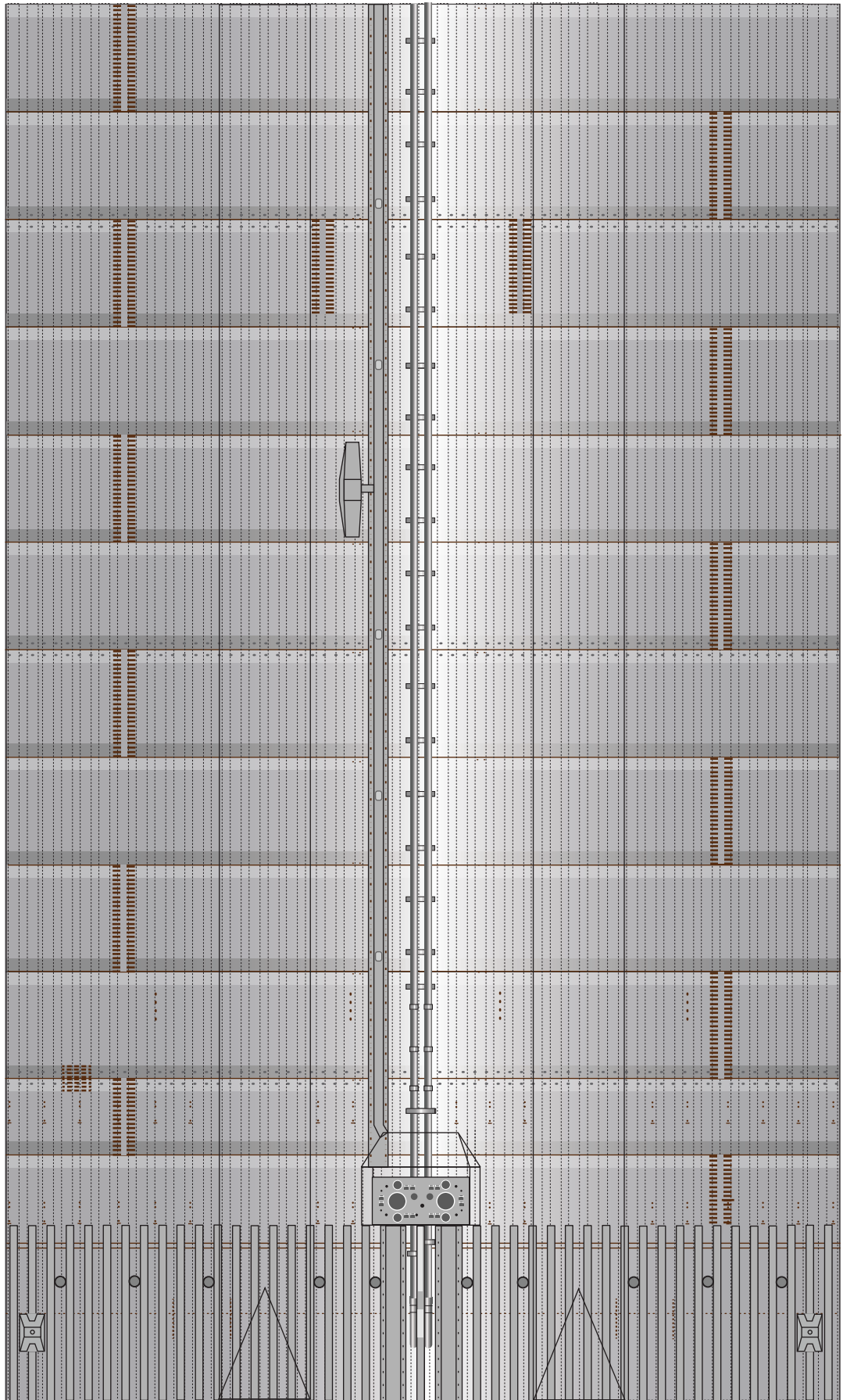
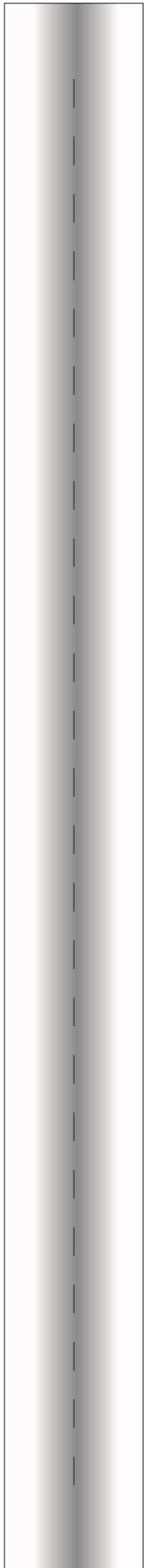



1:100 Scale



# COPV covers

FRONT

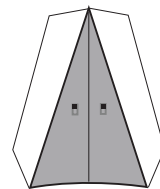
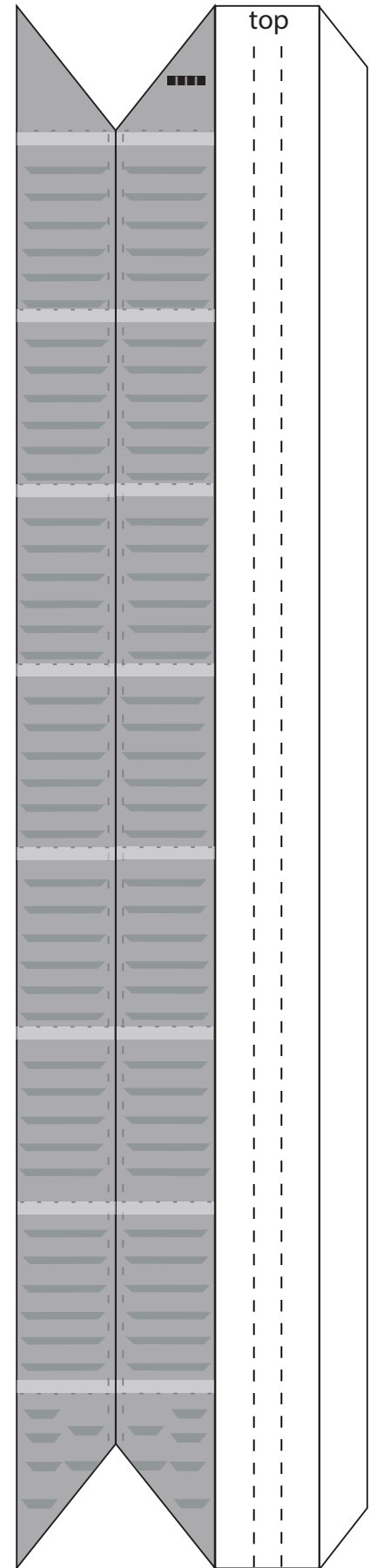
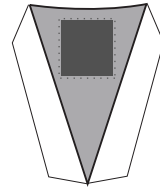
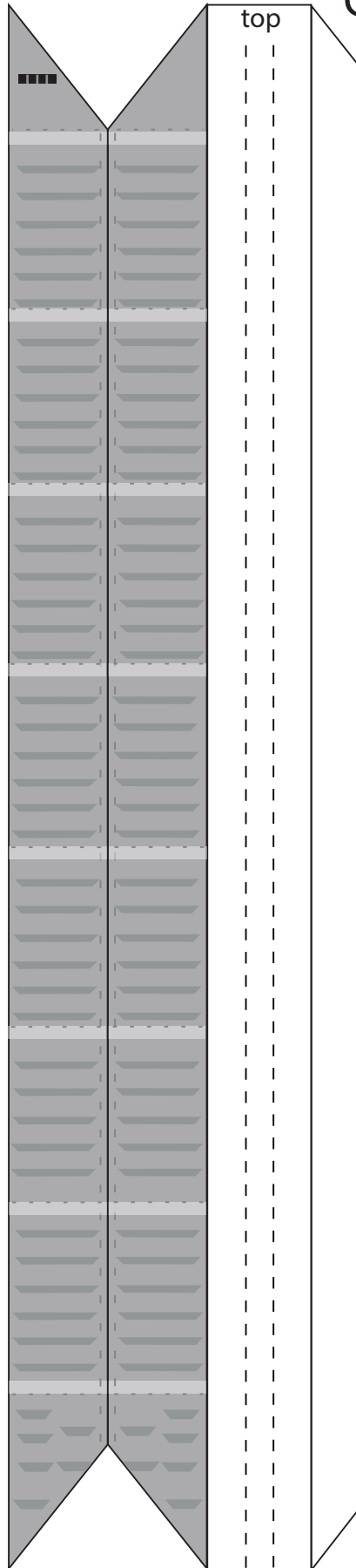
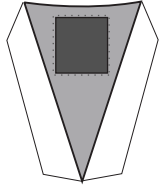



1:100 Scale



# COPV covers

Umbilical side

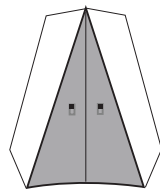
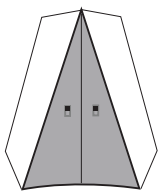
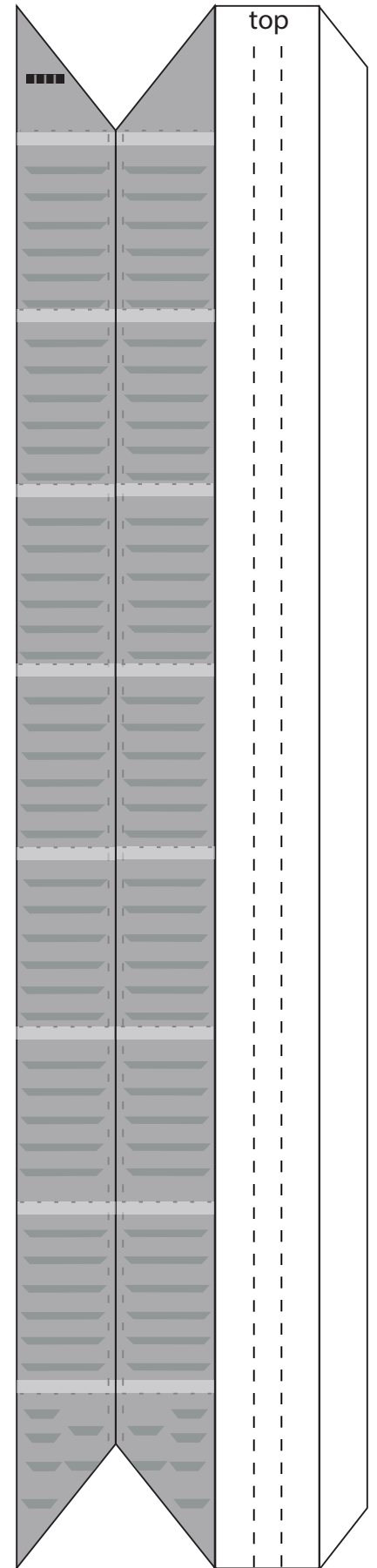
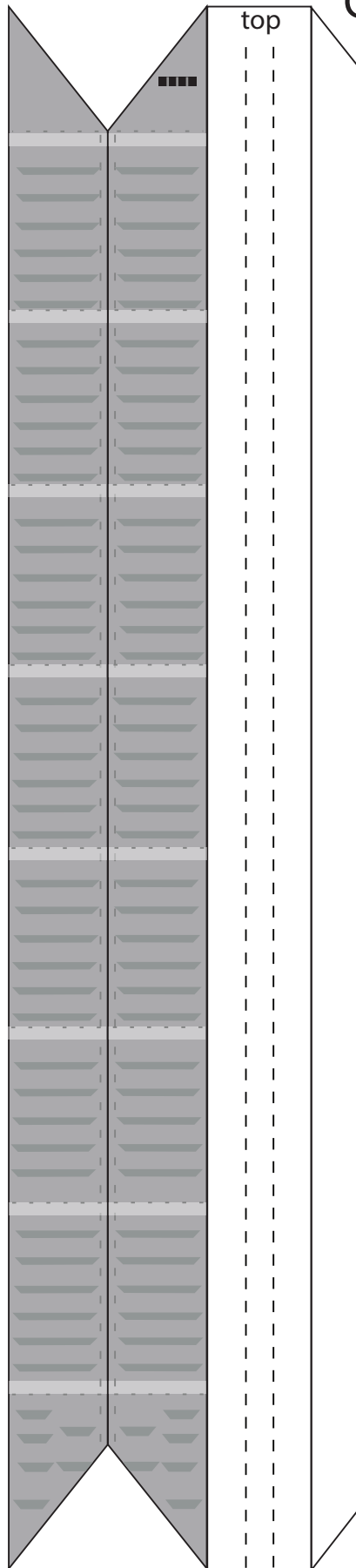
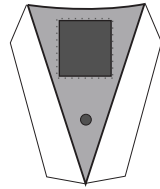
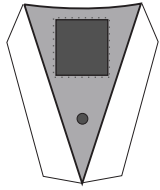



1:100 Scale



# SpaceX Starship **B13**

Print on Cardstock (110 lbs)

## Formers for top section

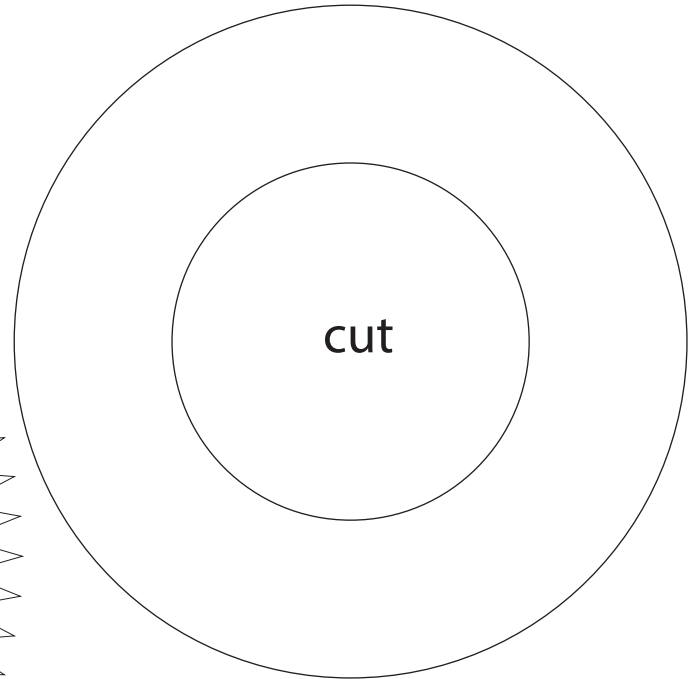
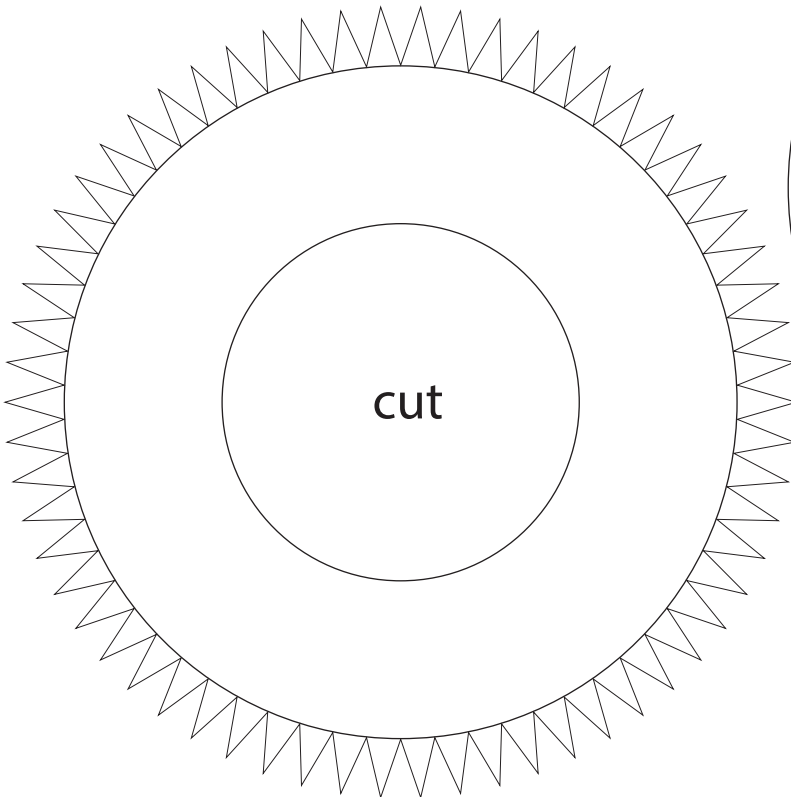
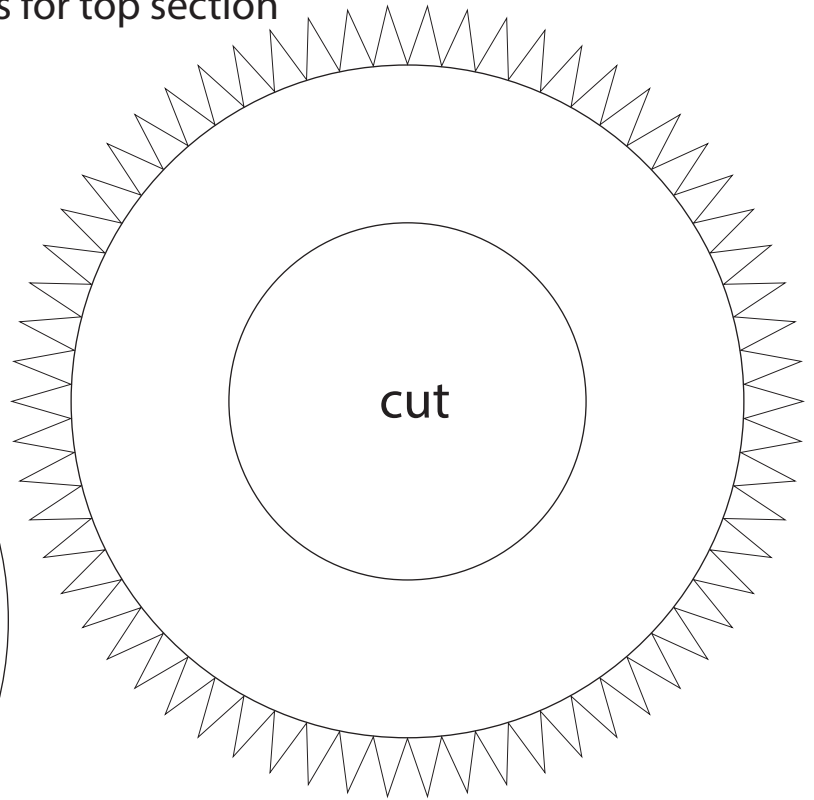
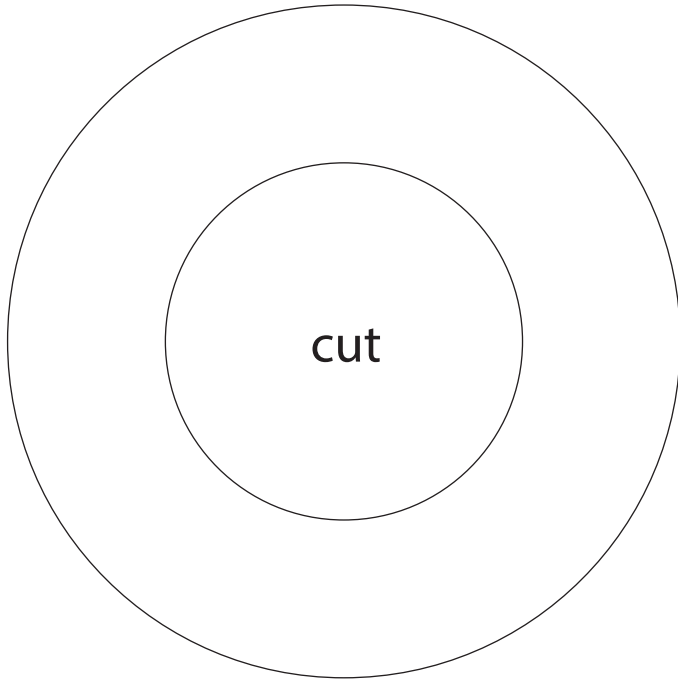

### IMPORTANT

Top former is glued 42 mm from top edge of top booster section.  
Bottom former is glued 20 mm from bottom edge of top booster section.



1:100 Scale



# SpaceX Starship **B13**

Print on Cardstock (110 lbs)

## Formers for middle body

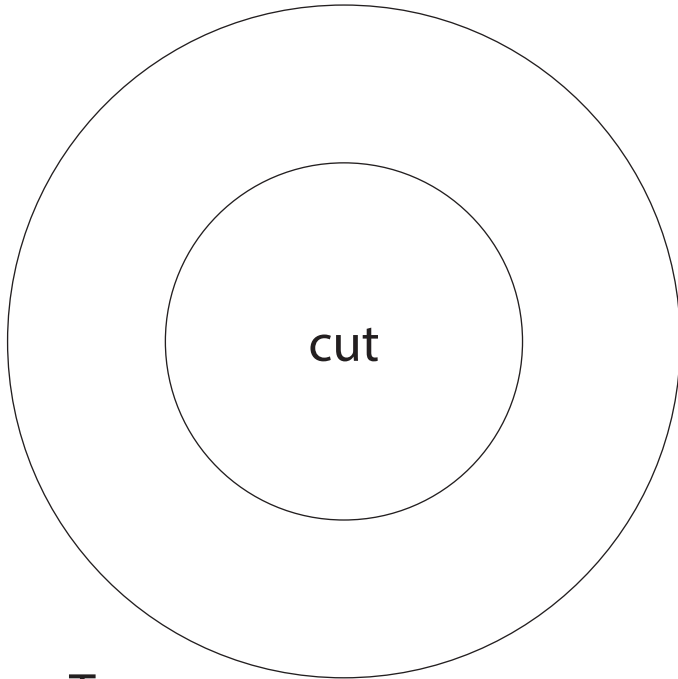

Top

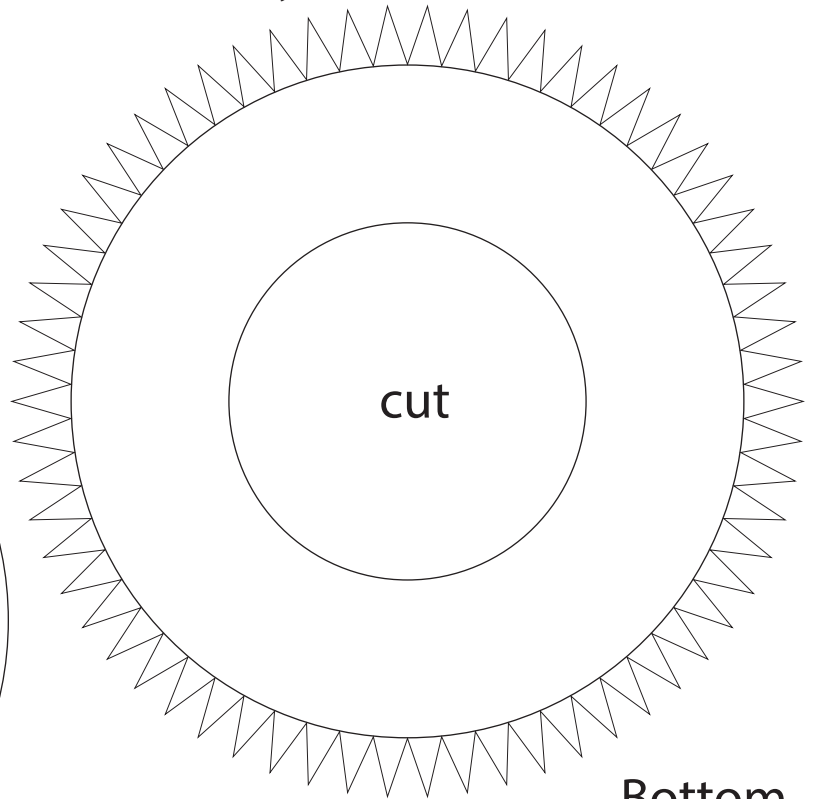

Bottom

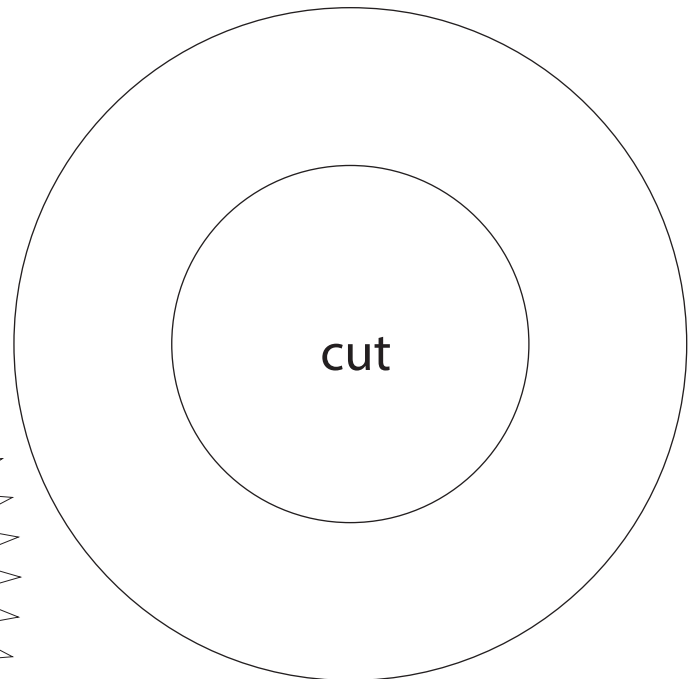
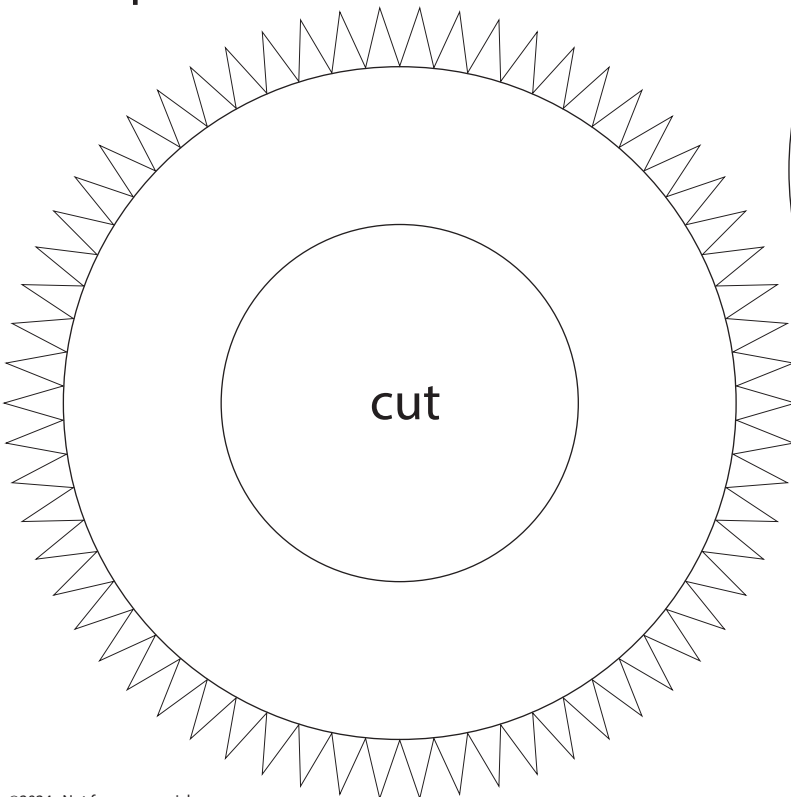

### IMPORTANT

Top former is glued 20 mm from top edge of middle booster section. Bottom former is glued 20 mm from bottom edge of middle booster section.



1:100 Scale

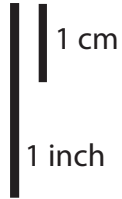

# SpaceX Starship **B13**

Print on Cardstock (110 lbs)

## Formers for bottom body

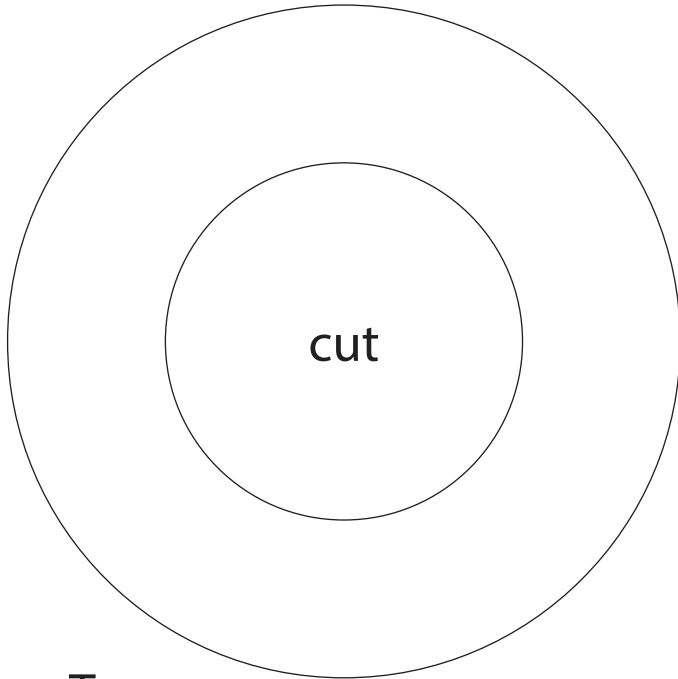

Top

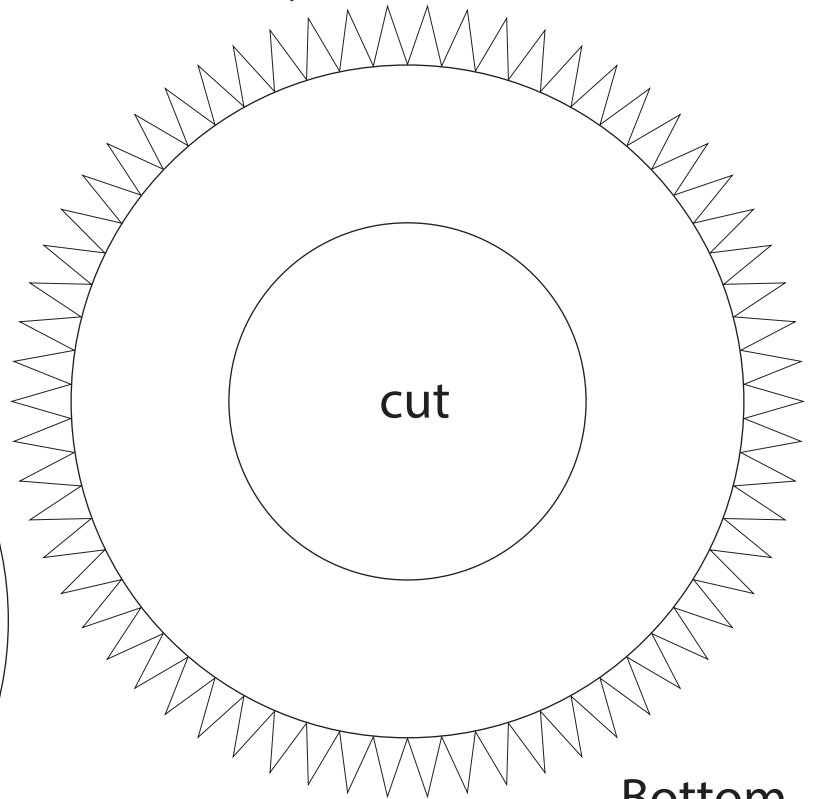

Bottom

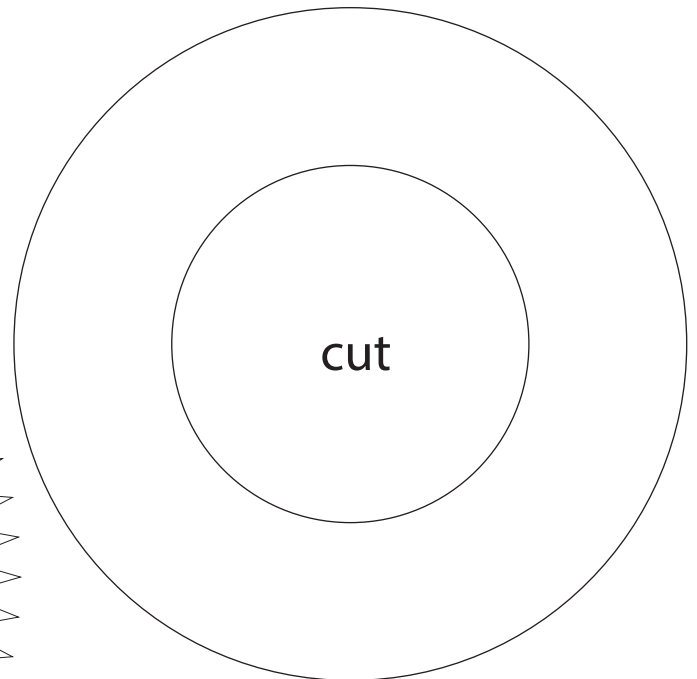
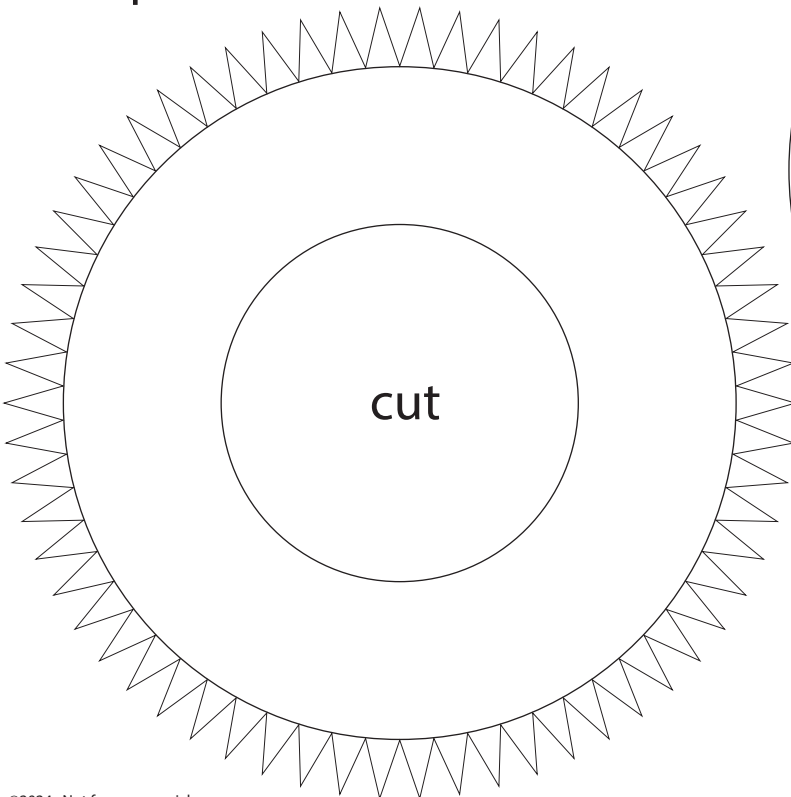

### IMPORTANT

Top former is glued 20 mm from top edge of bottom booster section. Bottom former is glued 19 mm from bottom edge of bottom booster section.



1 cm

1 inch

1:100 Scale

# SpaceX SuperHeavy

Print on Cardstock ( 110 lbs)

## Outer Raptor ring

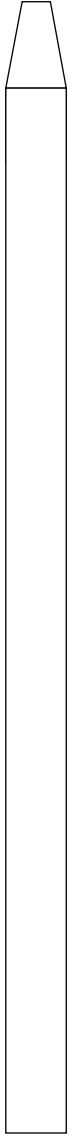
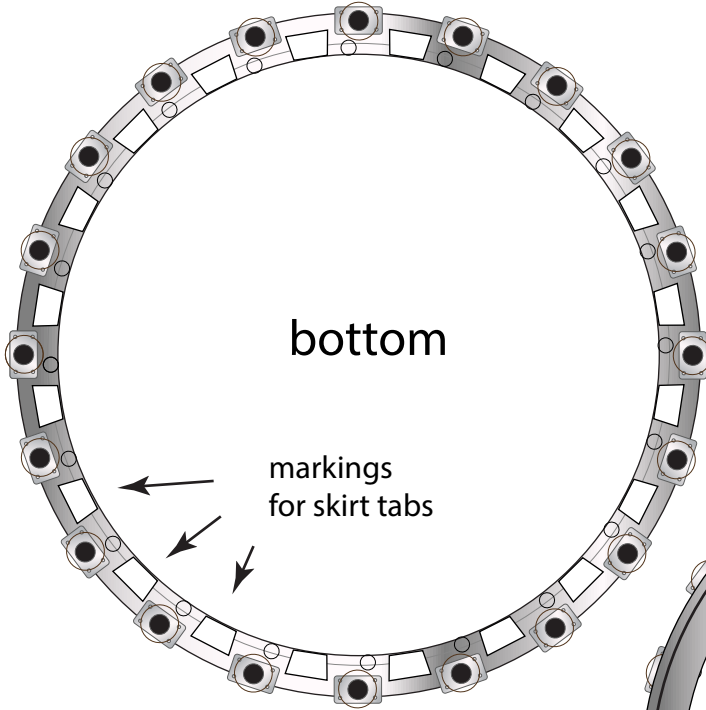

## Engine section interior layer







1 cm

1 inch

1:100 Scale

# SpaceX Heavy Booster 13

Print on Cardstock (90 lbs)

## Skirt for engine section

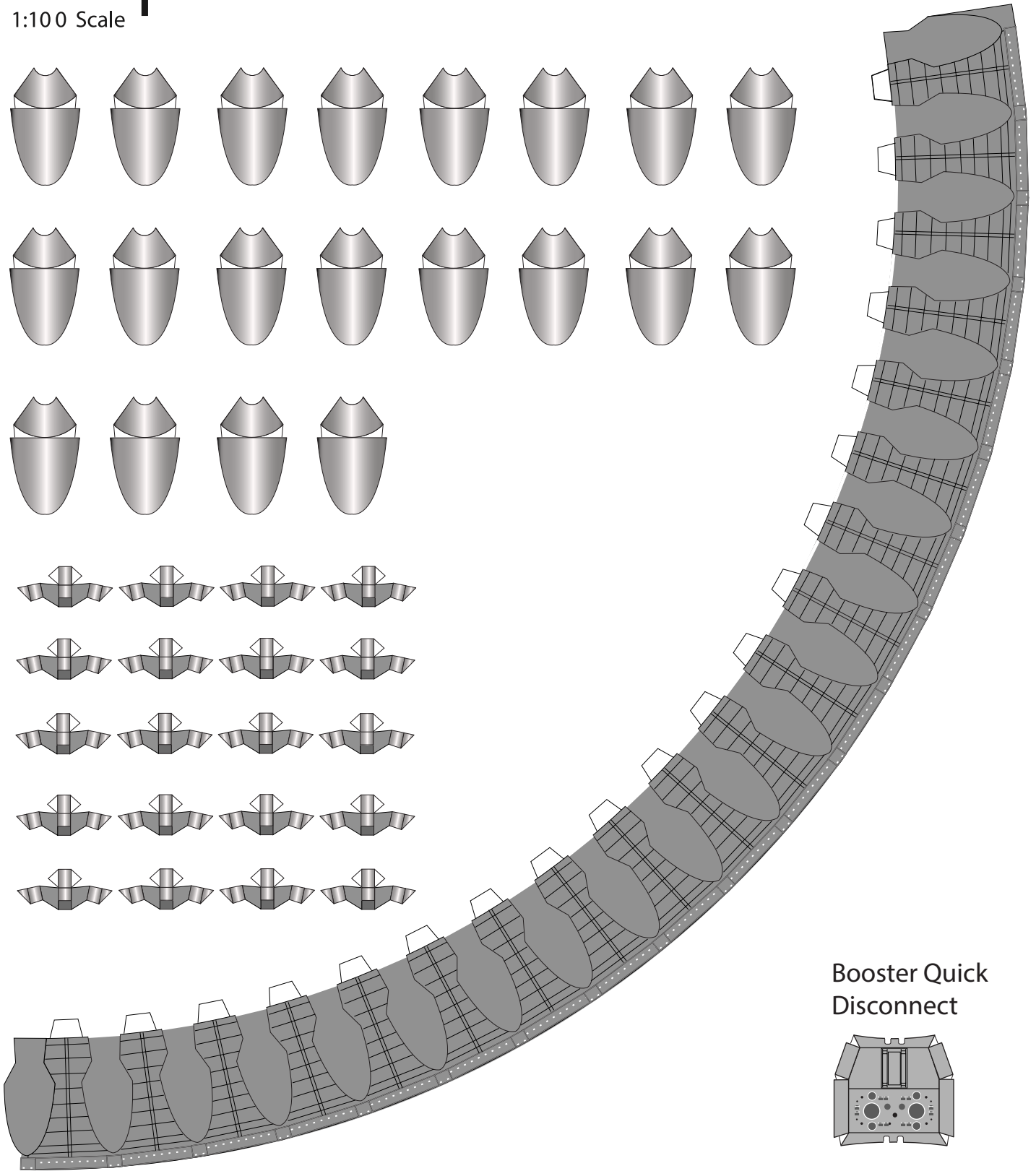
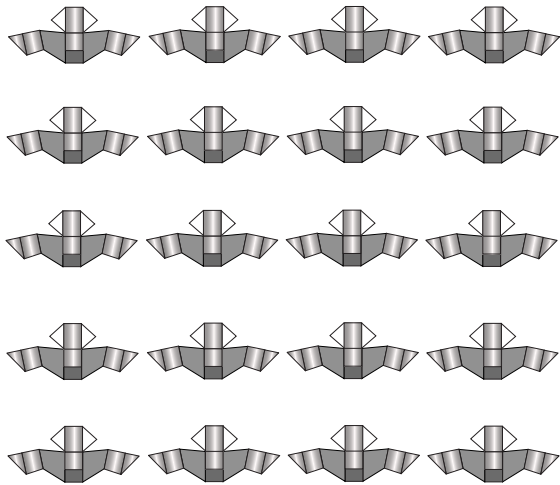
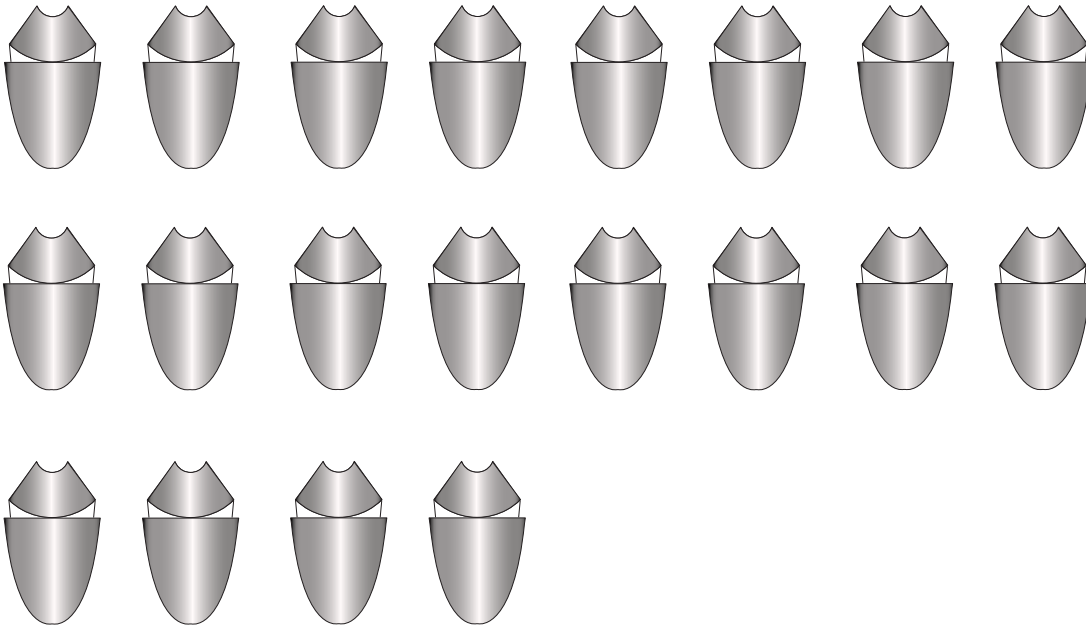

**Booster Quick Disconnect**

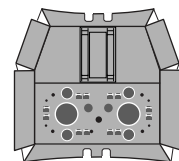

Place 2 magnets on the back to match with magnets from OLM's QD arm



1:100 Scale

# SpaceX Heavy Booster 13

## Skirt floor and wall

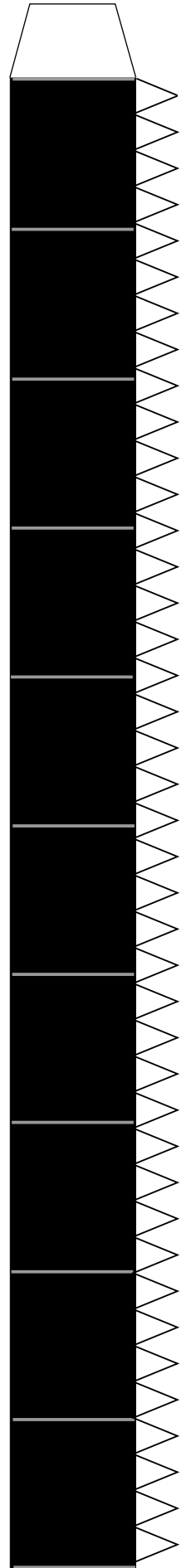
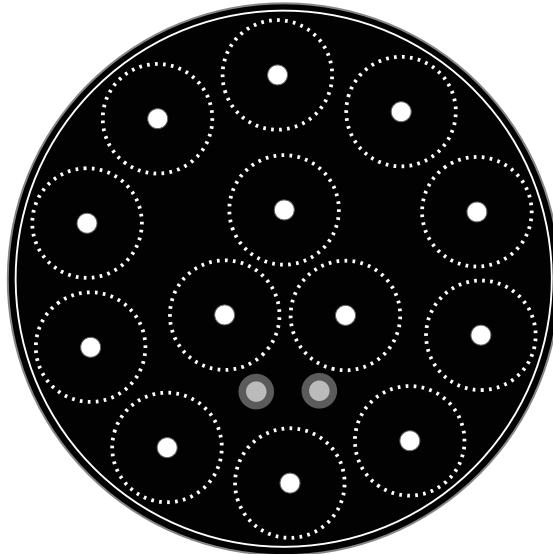
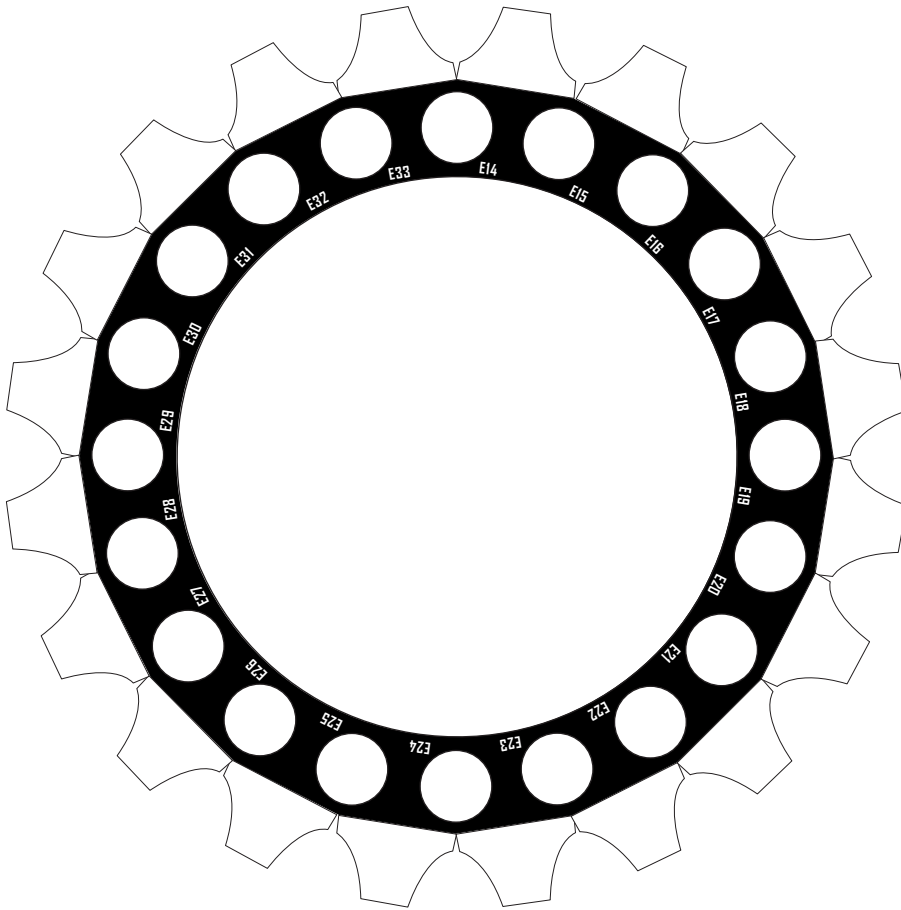

Print on Cardstock (90 lbs)



1 cm

1 inch

1:100 Scale

# B13 inner Raptor covers

Print on cardstock

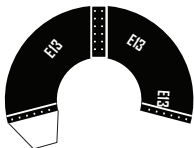
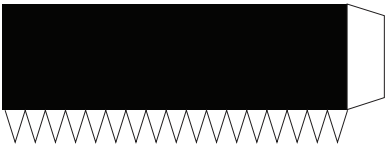
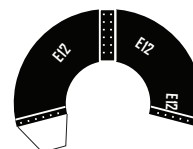
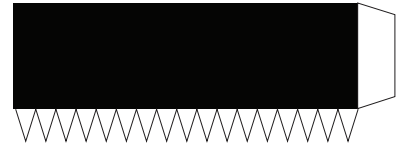
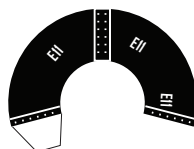
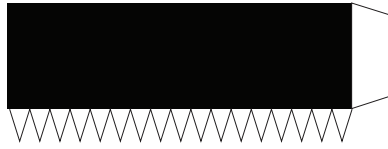
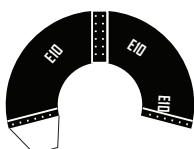
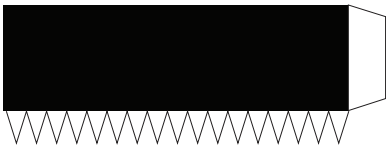
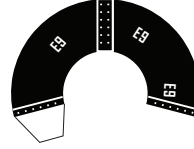
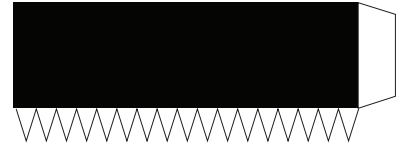
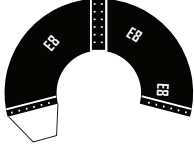
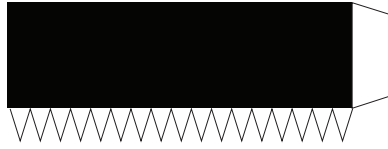
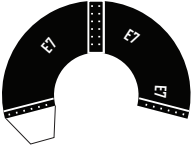
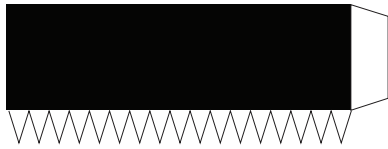
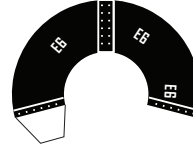
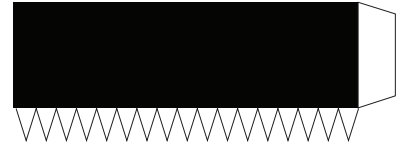
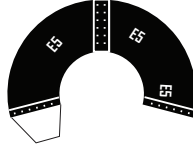
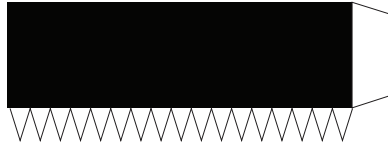
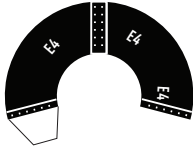
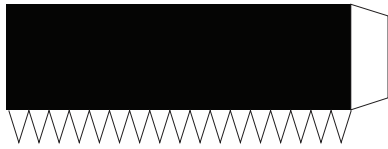
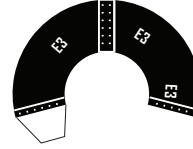
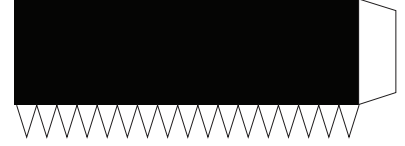
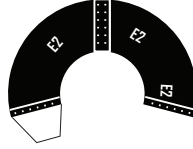
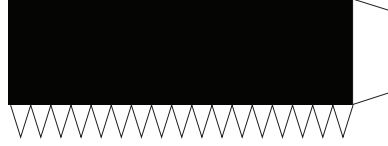
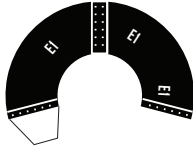
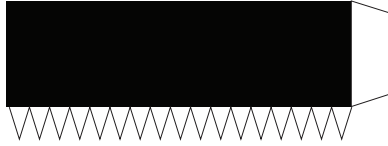



1 cm

# SuperHeavy Raptors

Print on Cardstock ( 110 lbs)

## B13

1 inch

1:100 Scale

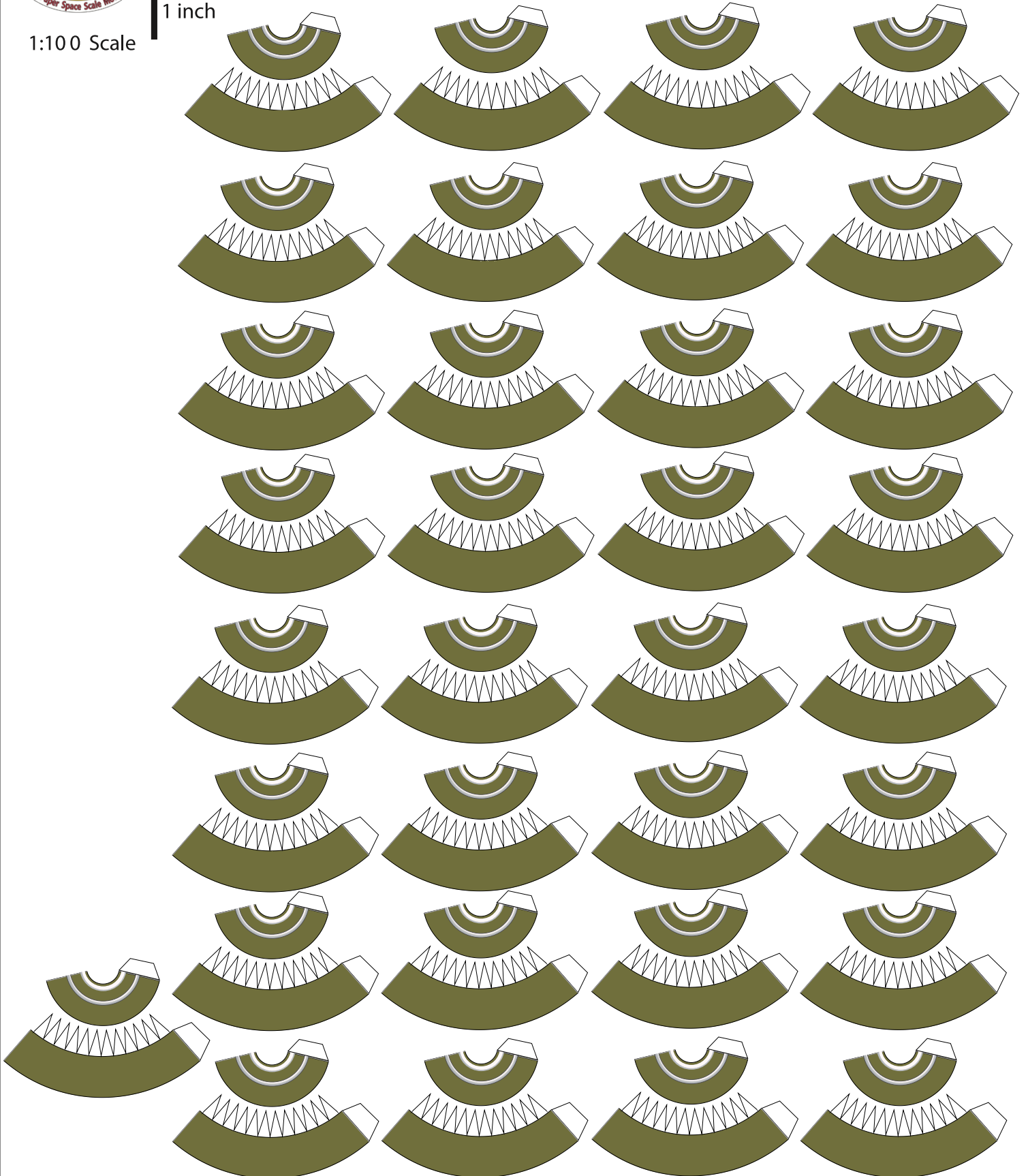



# SuperHeavy Raptors BACKPRINT

Print on Cardstock ( 110 lbs)

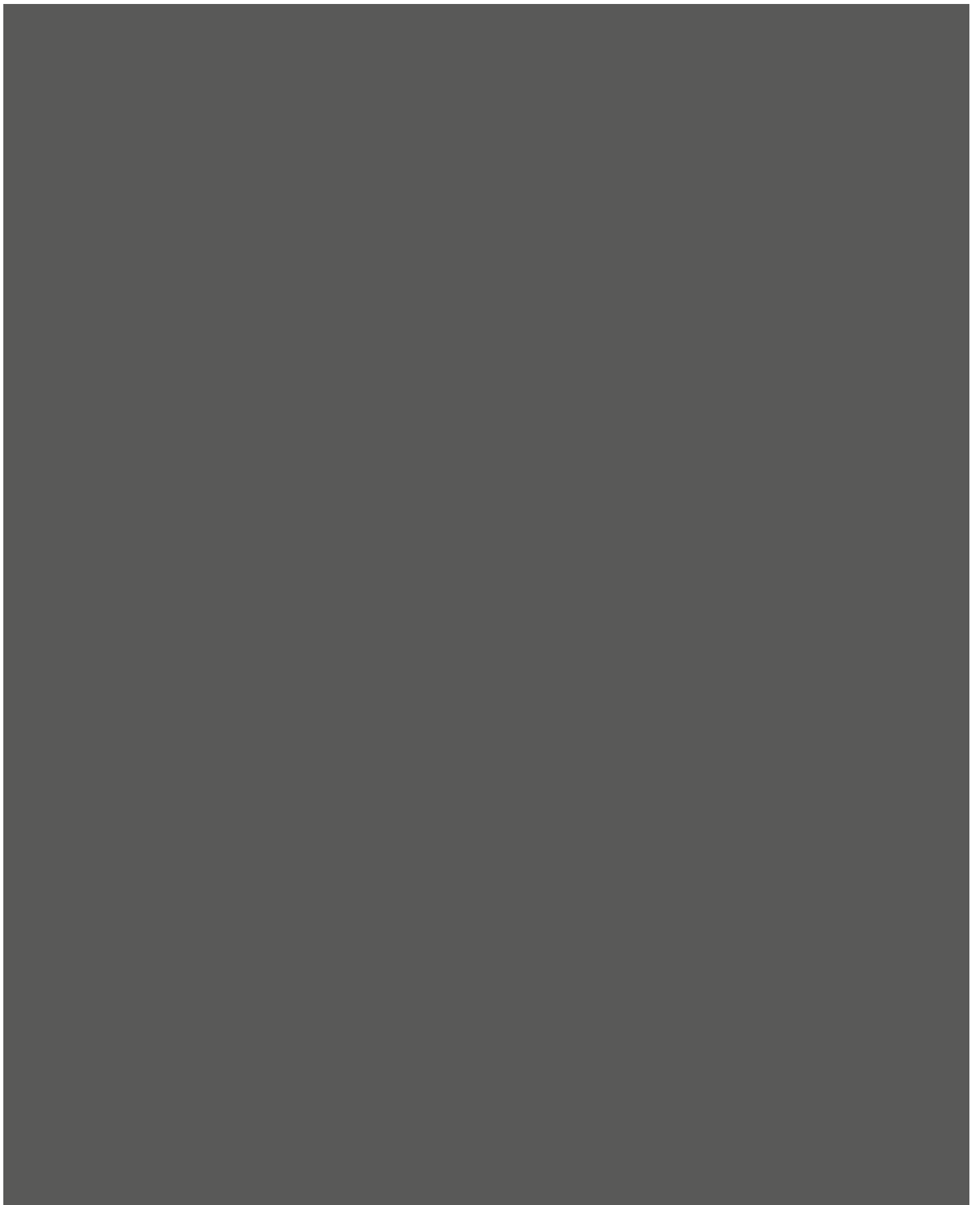



1 cm

1 inch

1:100 Scale

# SpaceX Heavy Booster 13

## Raptor location

Umbilical side

