

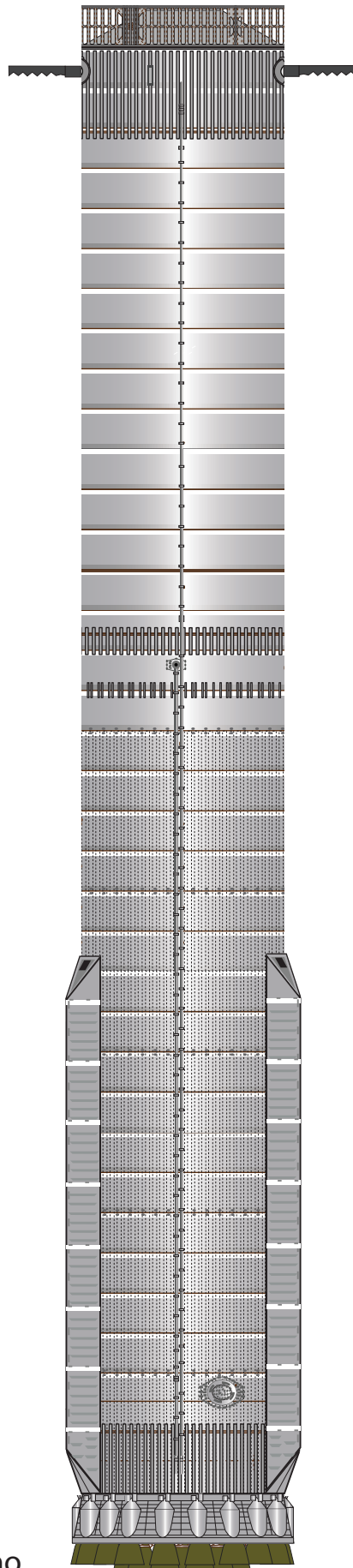

1:100 Scale

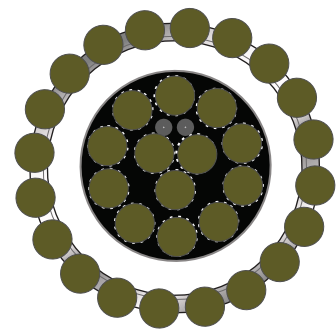

# B15

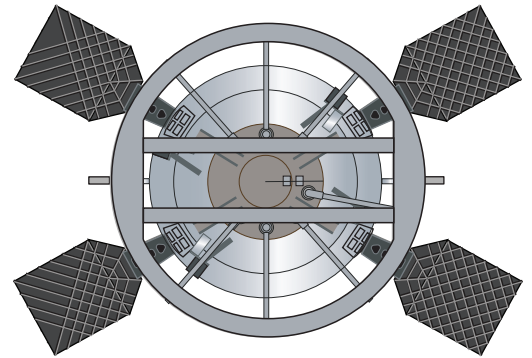
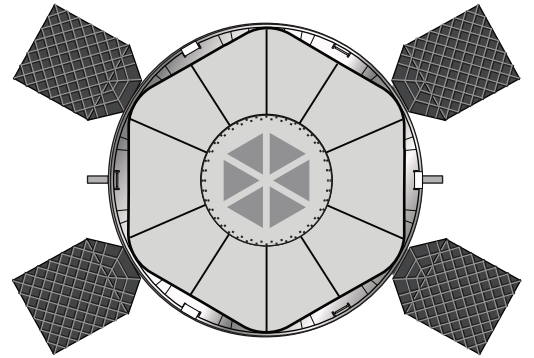

Designed by Alfonso X Moreno  
©2025 Not for commercial use



1 cm

1 inch

1:100 Scale

# Hot staging Ring

Print on Cardstock ( 110 lbs)

## Top ring

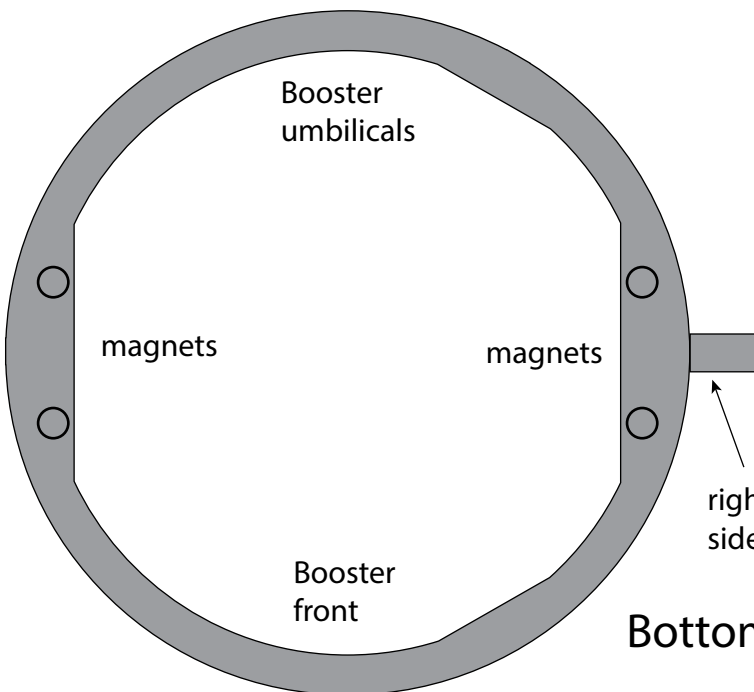
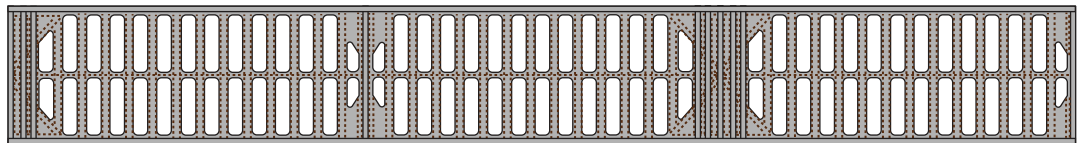
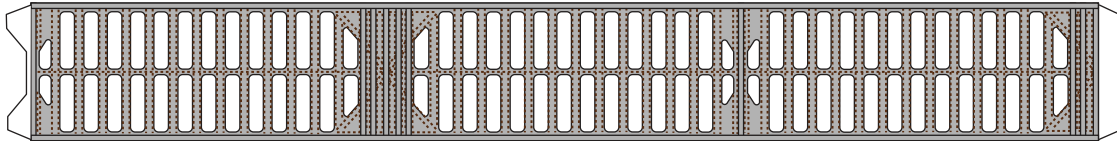
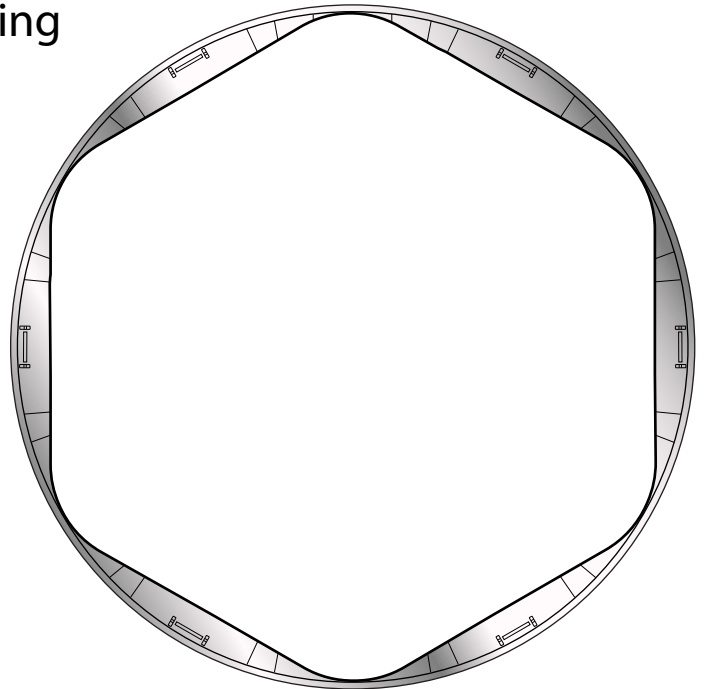
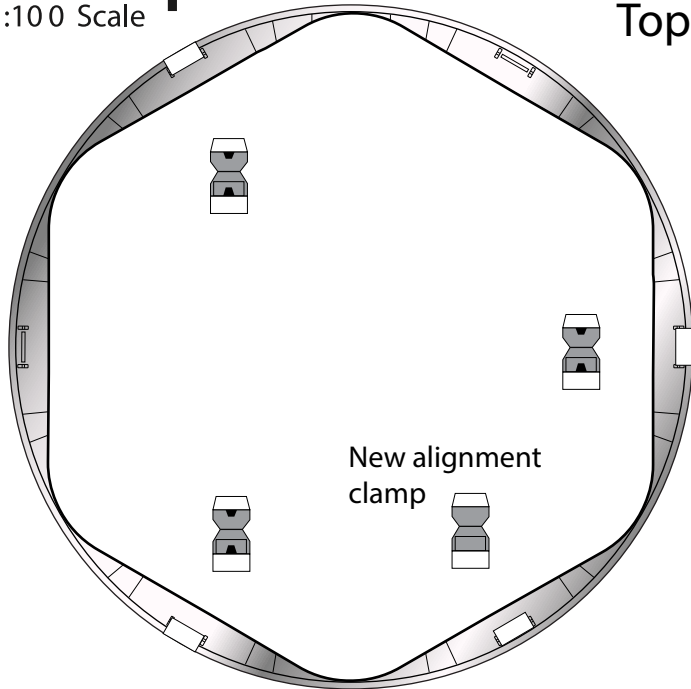

## Bottom ring

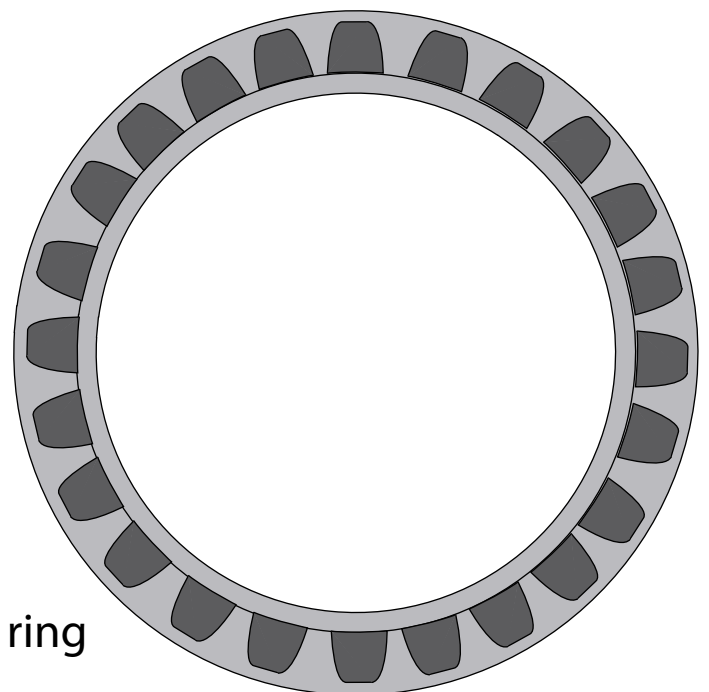



1:100 Scale

# Hot staging Ring

Print on Cardstock ( 110 lbs)

## Back Print





1 cm

1 inch

1:100 Scale

# Hot staging Ring

Print on Cardstock ( 110 lbs)

## Simple version

### Exterior skin

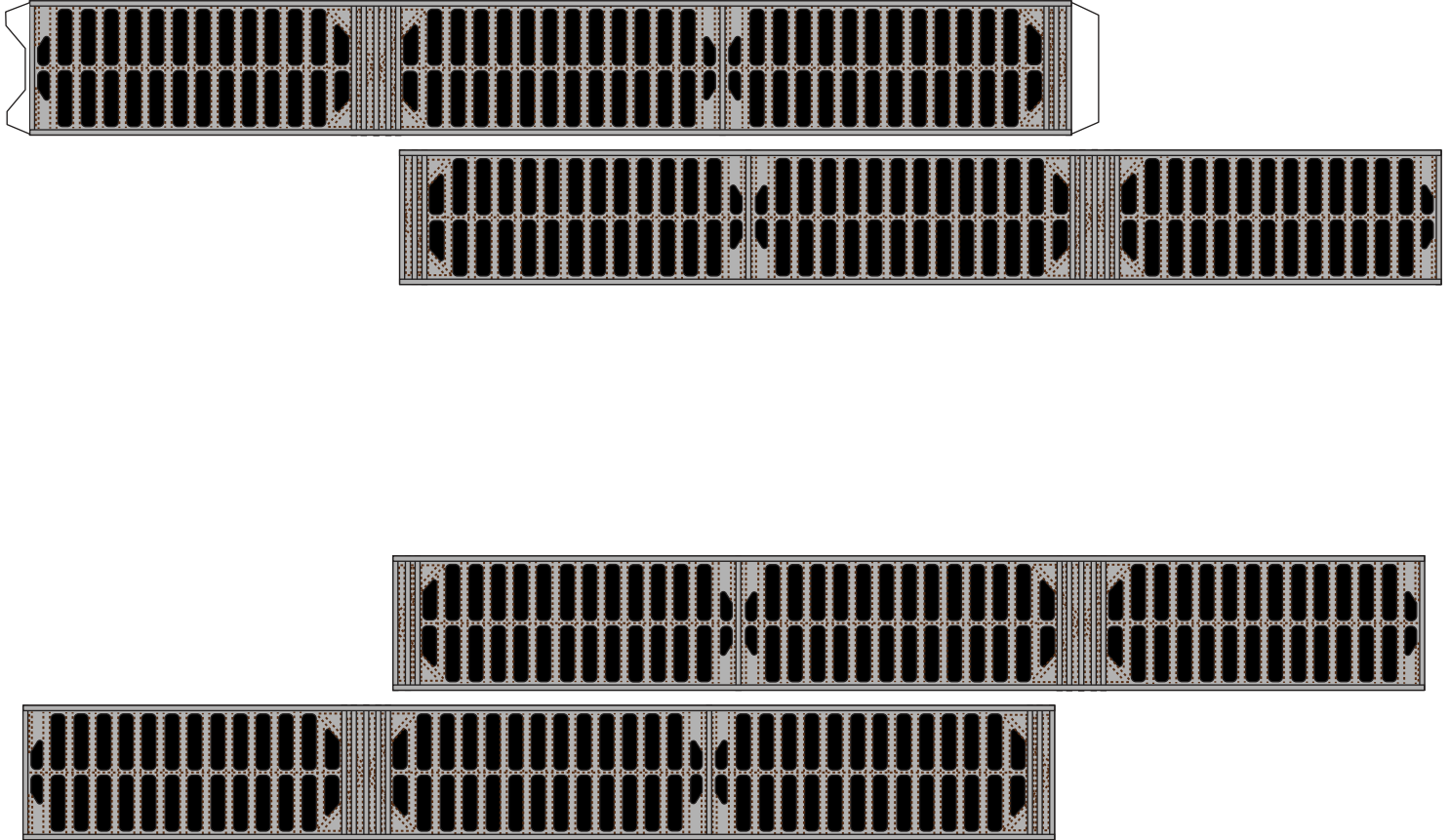

### Interior skin



1 cm

1 inch

1:100 Scale

# Hot staging Ring Dome

Print on Cardstock ( 110 lbs)

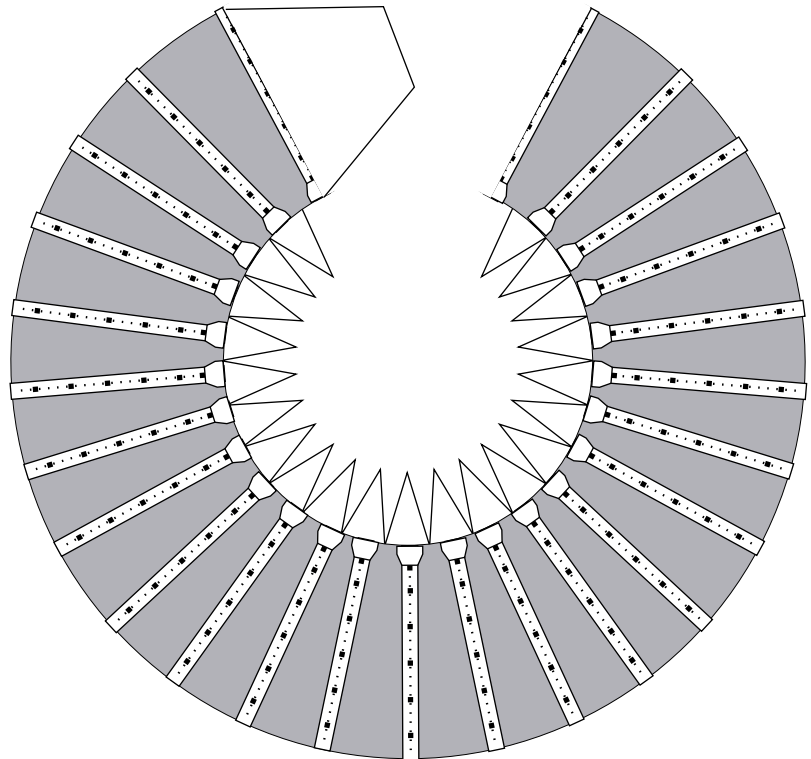
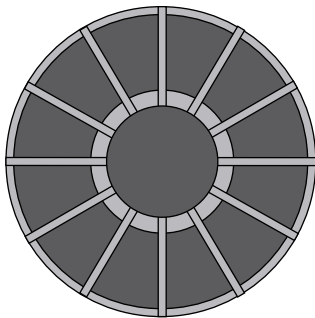
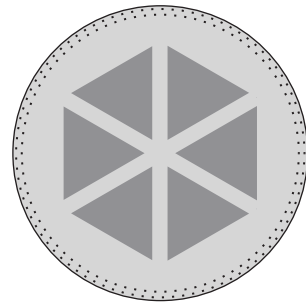
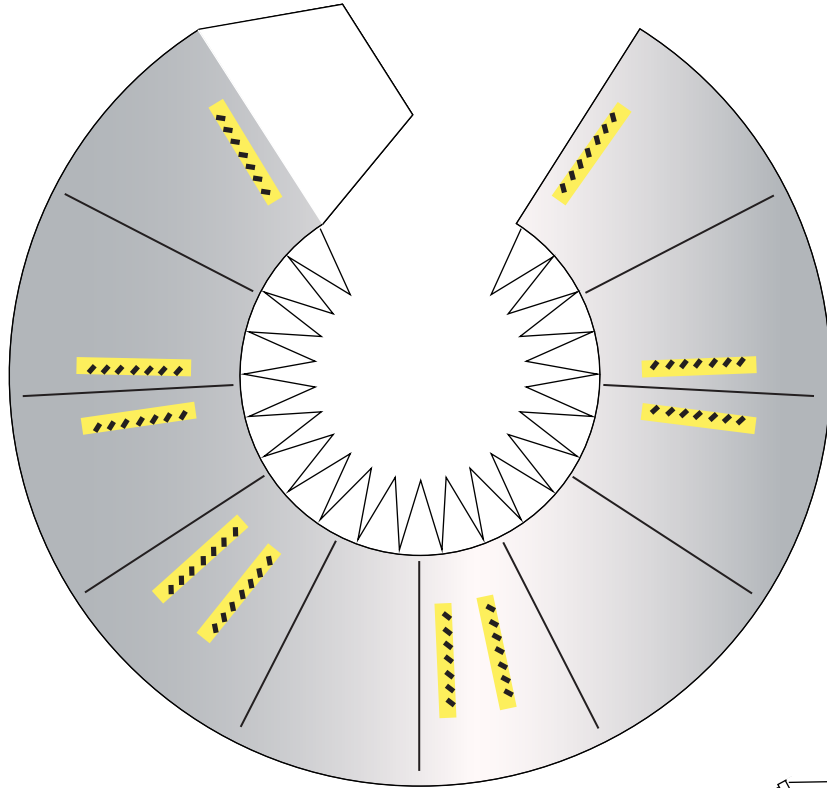



1 cm

1 inch

1:100 Scale

# SpaceX SuperHeavy

Print on Cardstock ( 110 lbs)

## Top ring

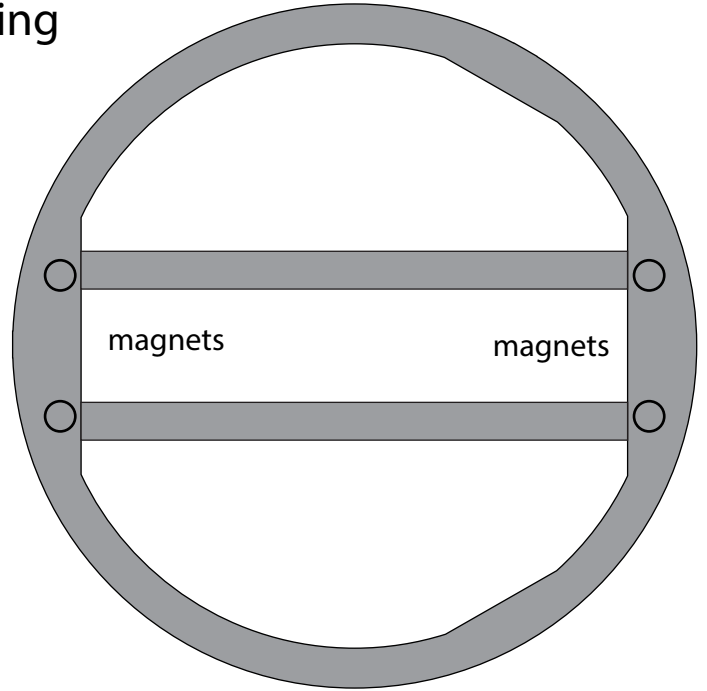
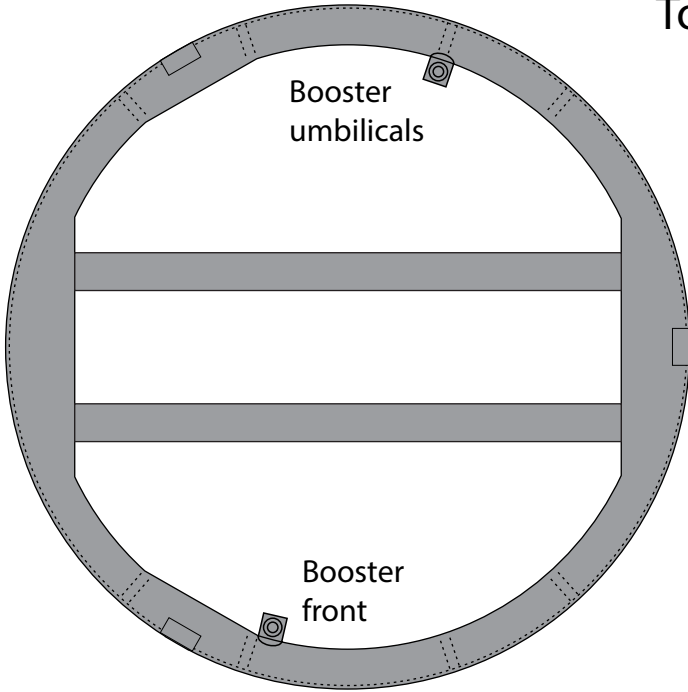

## Bottom ring

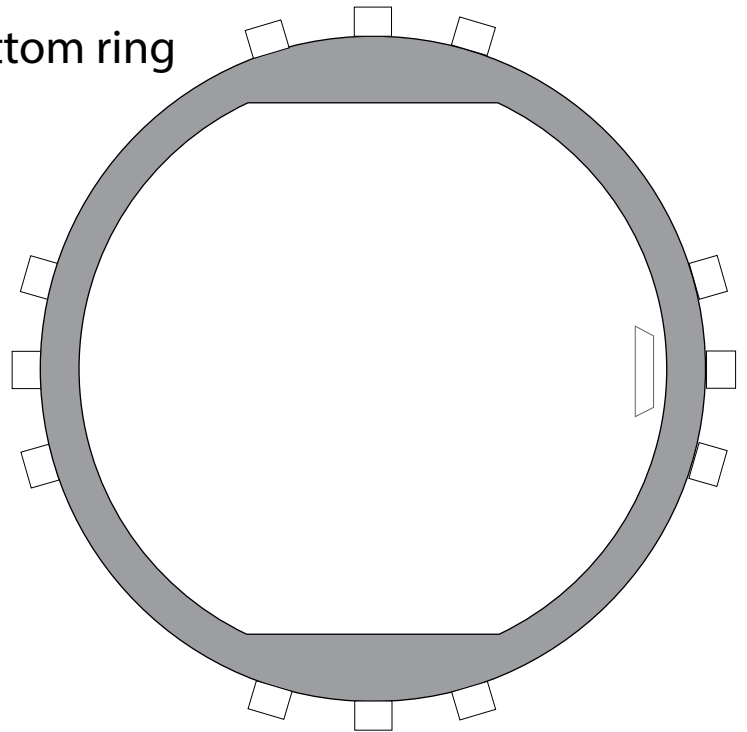
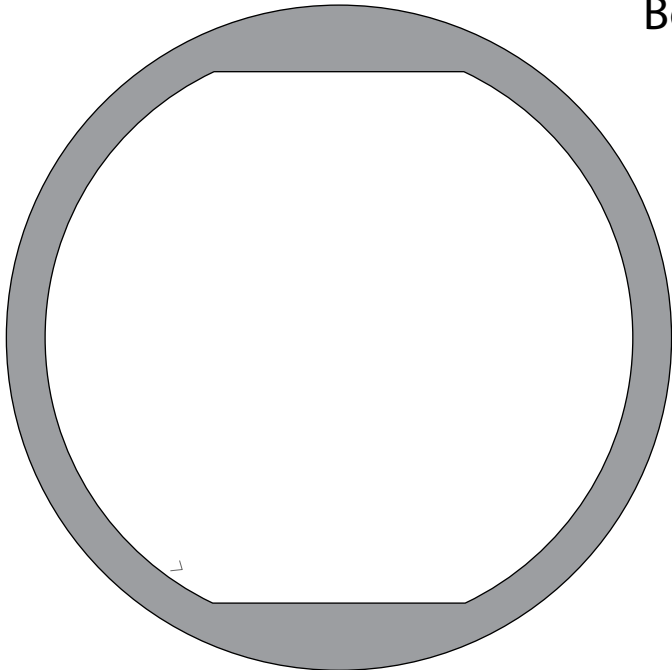



1 cm

1 inch

1:100 Scale

# SuperHeavy B15 Upper Dome

Print on Cardstock (110 lbs)

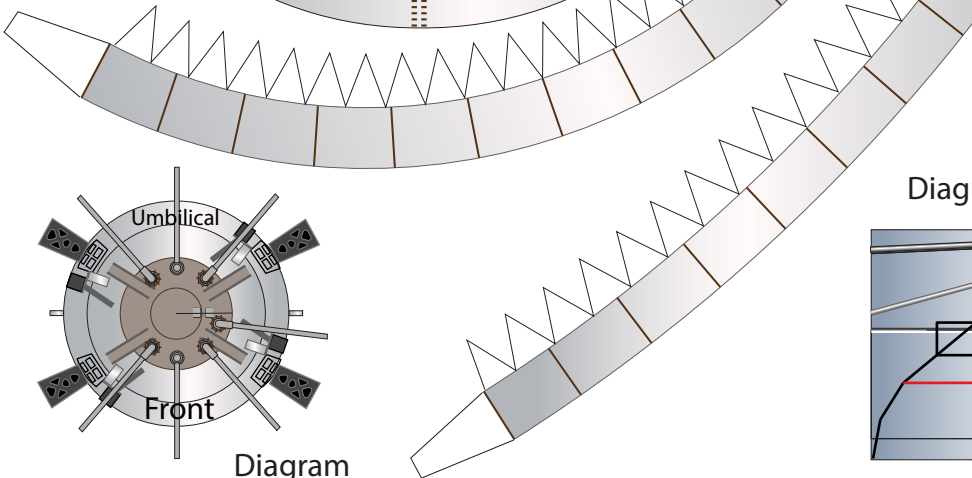
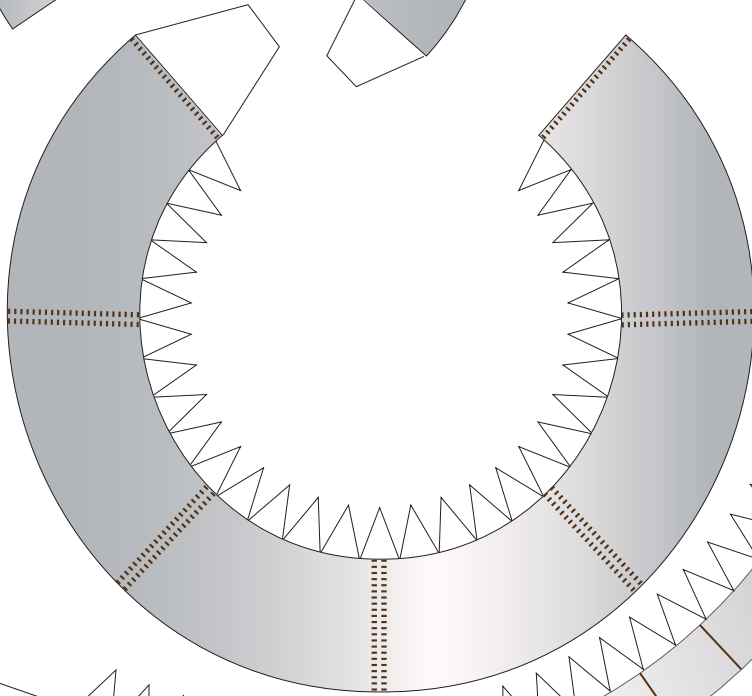
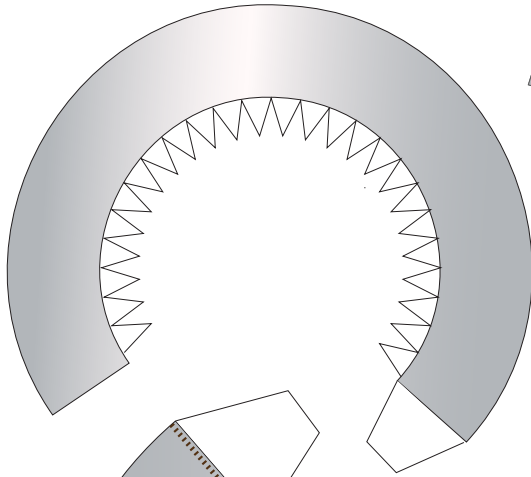
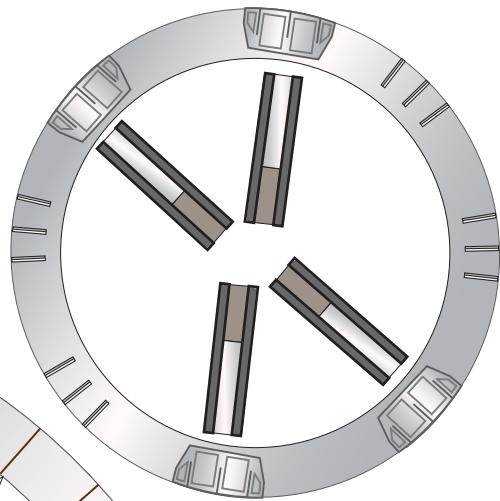
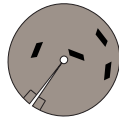
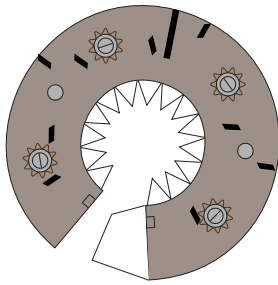

Ch4 vent pipes

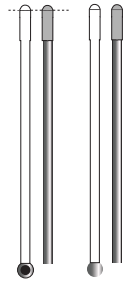

Ch4 vent pipes

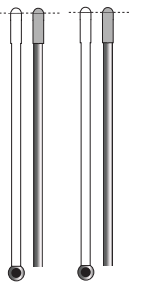

New Ch4

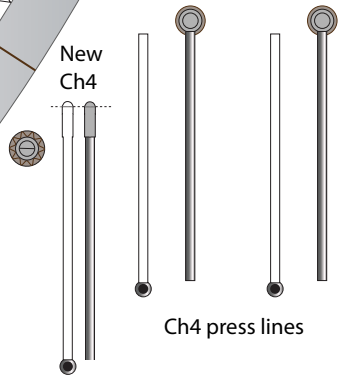

Ch4 press lines

Diagram

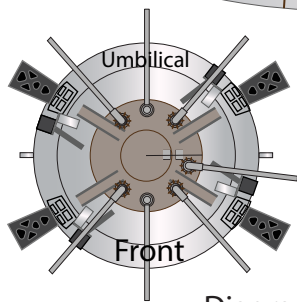
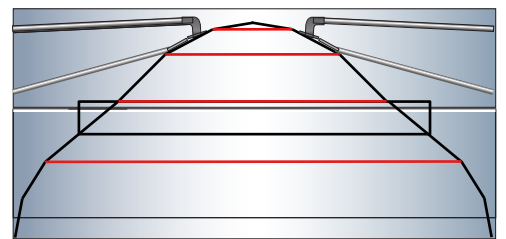

Umbilical

Front

Diagram



1 cm

1 inch

1:100 Scale

# SpaceX Starship B15

Print on Cardstock (110 lbs)

## Grid Fins servo motors and Connectors

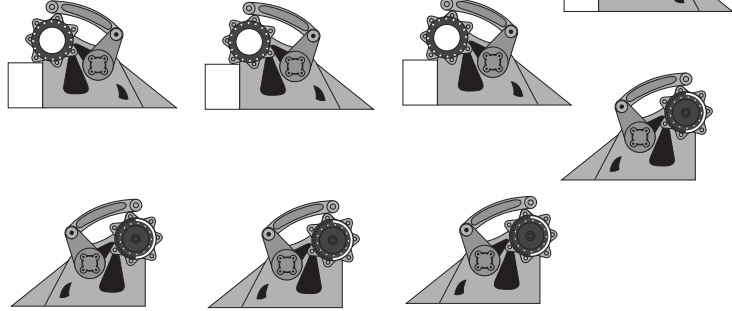
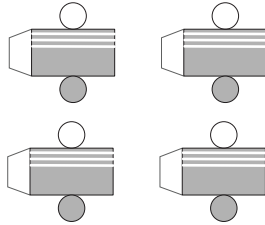
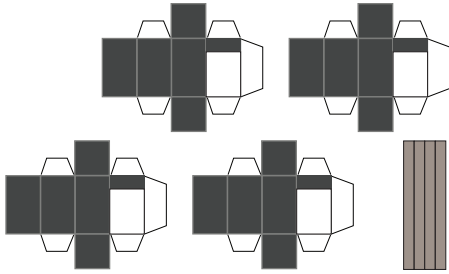

top/middle

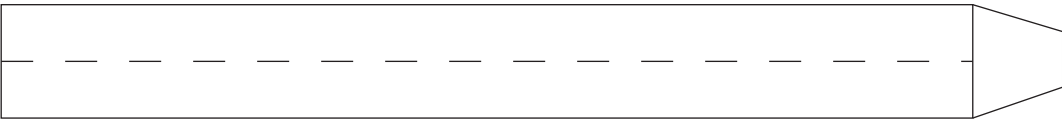

middle/bottom



This wall corresponds to the front side of booster

Glue tip of the Ch4 press line to cover the black circles

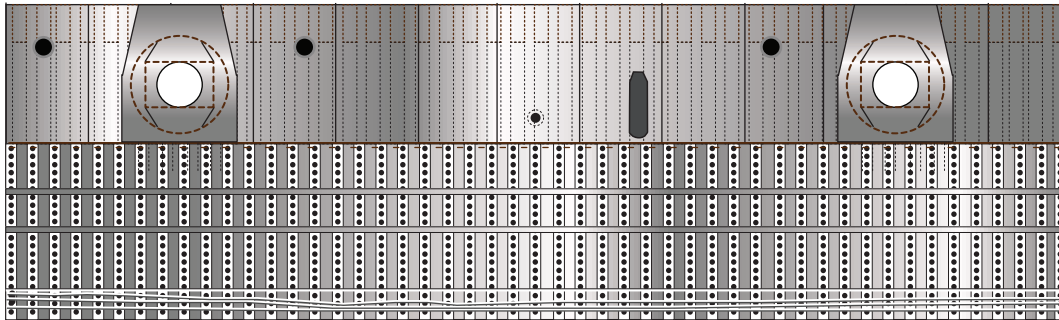

This wall corresponds to the umbilical side of booster

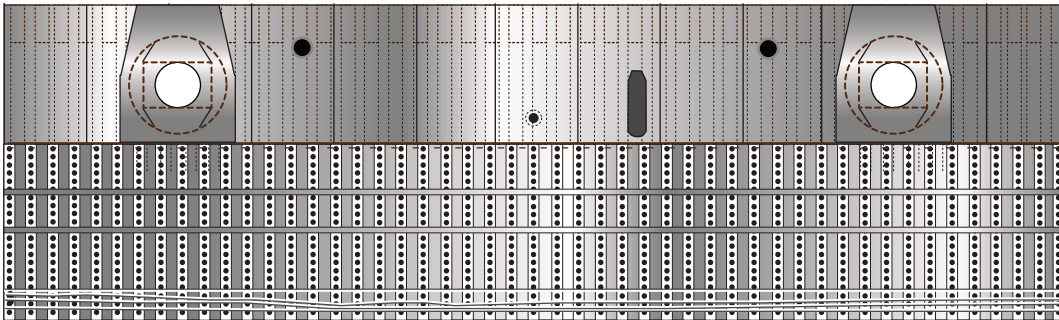

Interior wall for upper dome section





1 cm

1 inch

1:100 Scale

# SuperHeavy Grid Fins

Print on Cardstock ( 110 lbs)

## Simple version

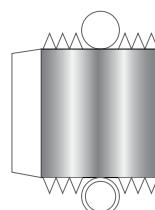
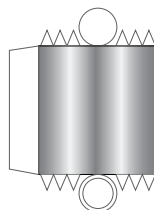
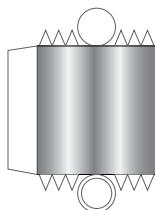
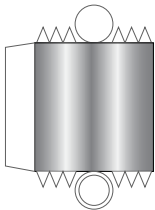
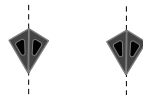
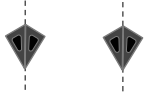
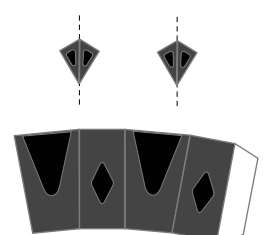
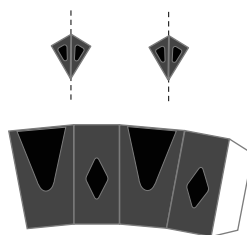
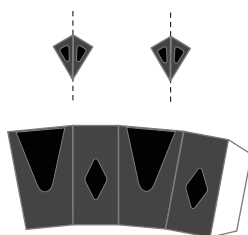
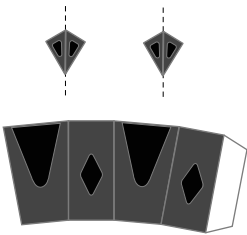
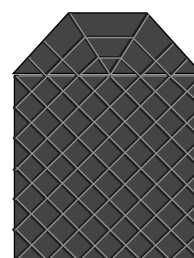
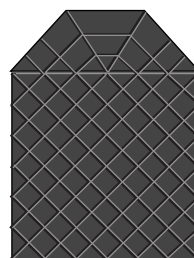
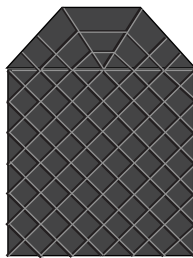
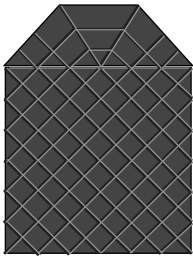
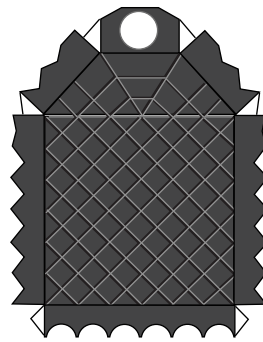
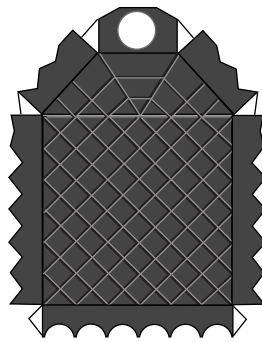
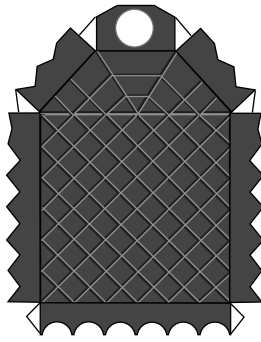
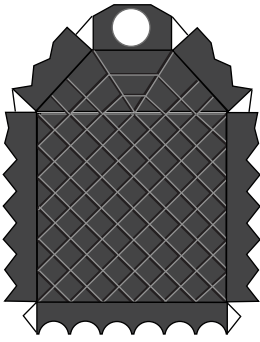



1 cm

1 inch

1:100 Scale

## SuperHeavy Grid Fins

Print on Cardstock ( 110 lbs)

# Back Print





1 cm

1 inch

1:100 Scale

# SuperHeavy Grid Fins

Print on Cardstock ( 110 lbs)

## Detailed version

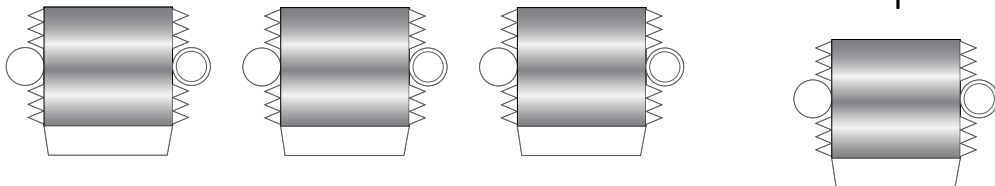
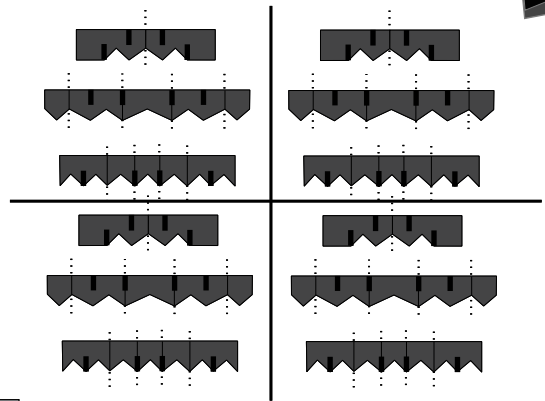
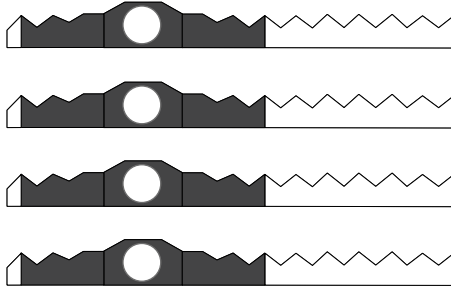
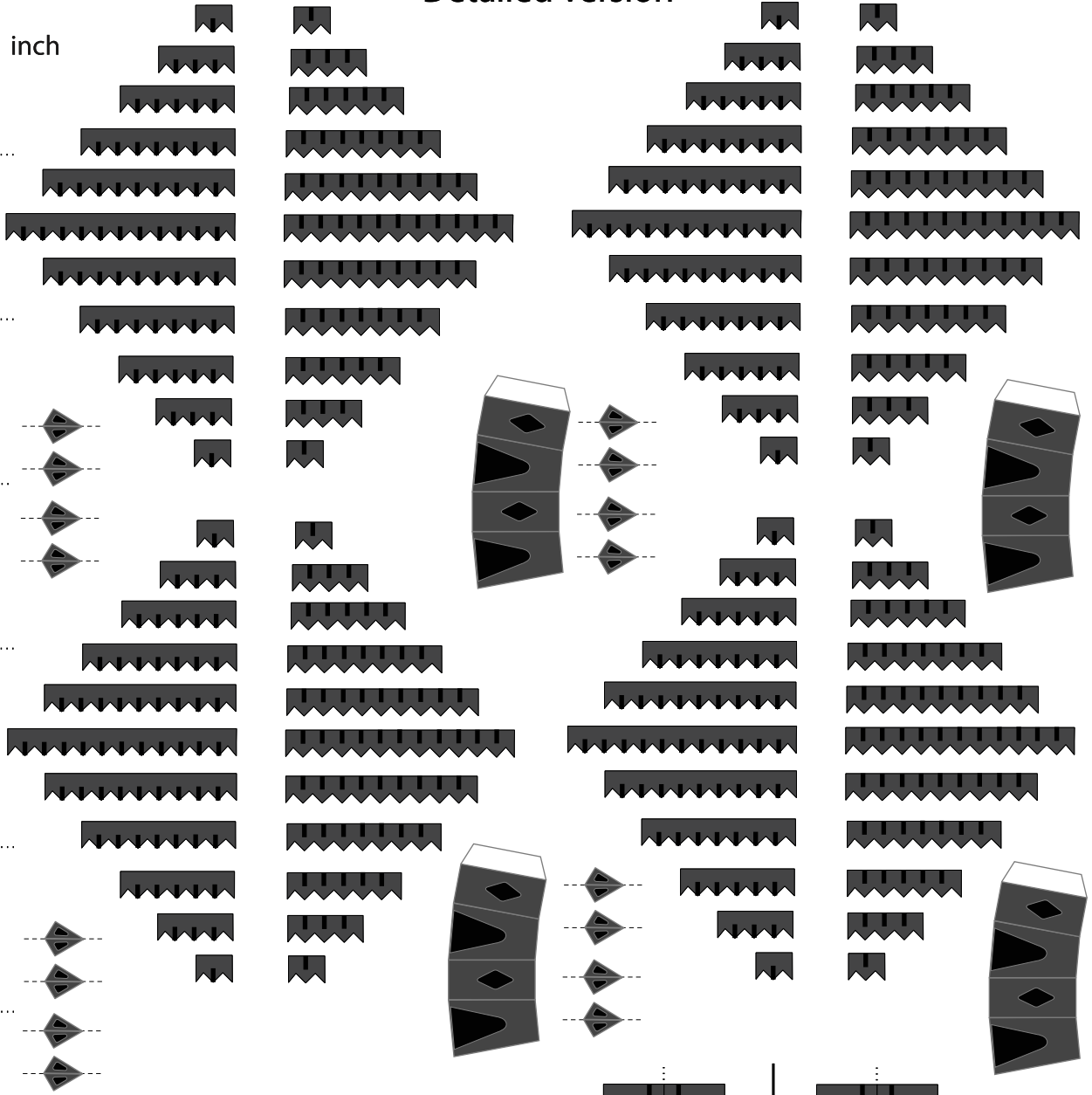
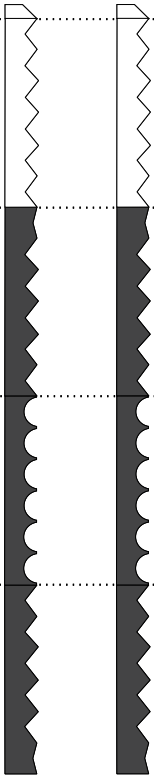



# SuperHeavy Grid Fins

Print on Cardstock ( 110 lbs)

Back Print





1:100 Scale



# Booster 15

Print on Cardstock (110 lbs)

Belly side top

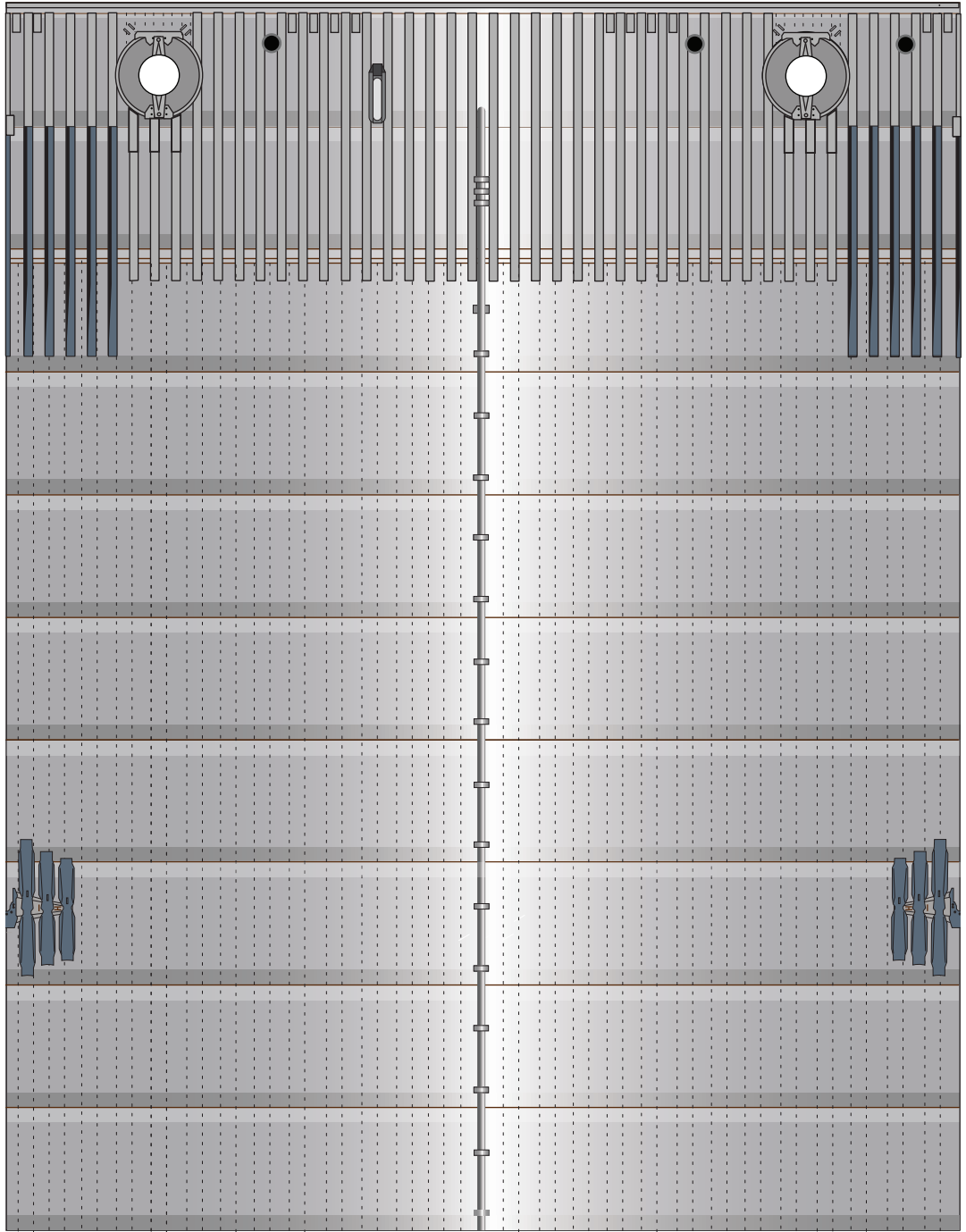
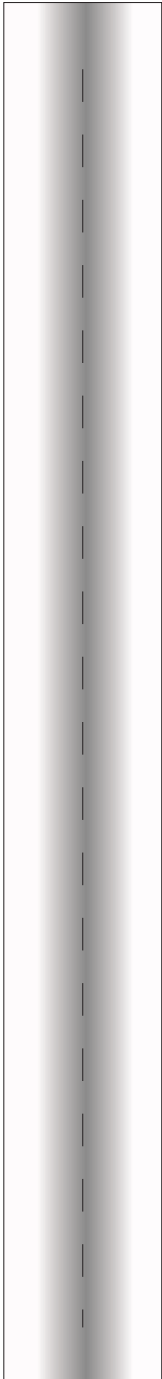
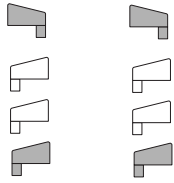



1:100 Scale



# Booster 15

Print on Cardstock (110 lbs)

Back side top

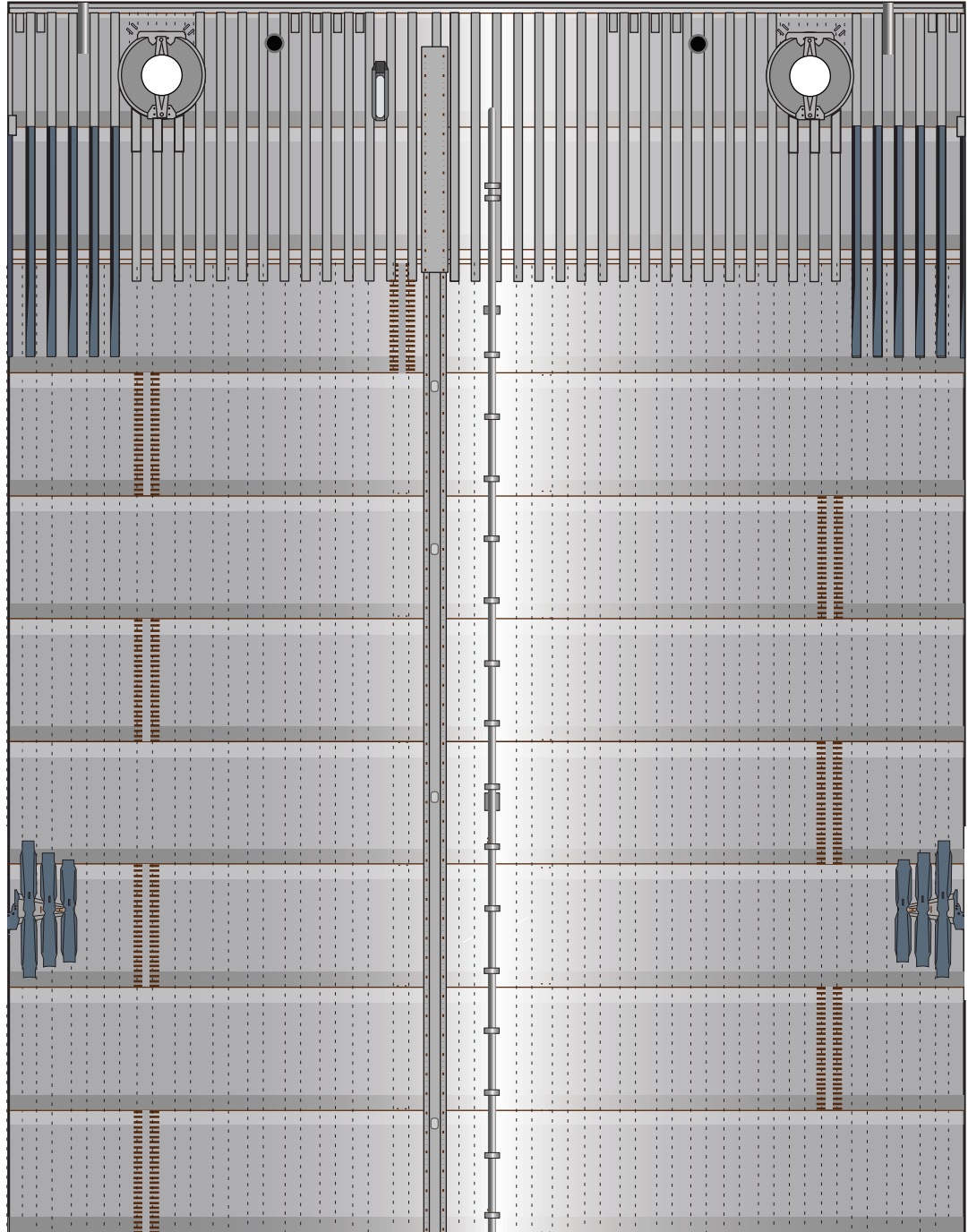
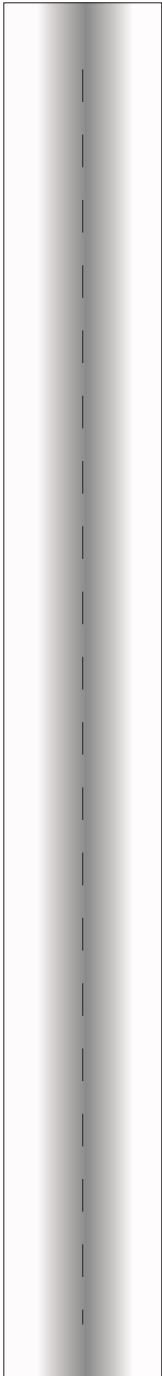



1:100 Scale

# Booster 15

Print on Cardstock (110 lbs)  
Belly side middle

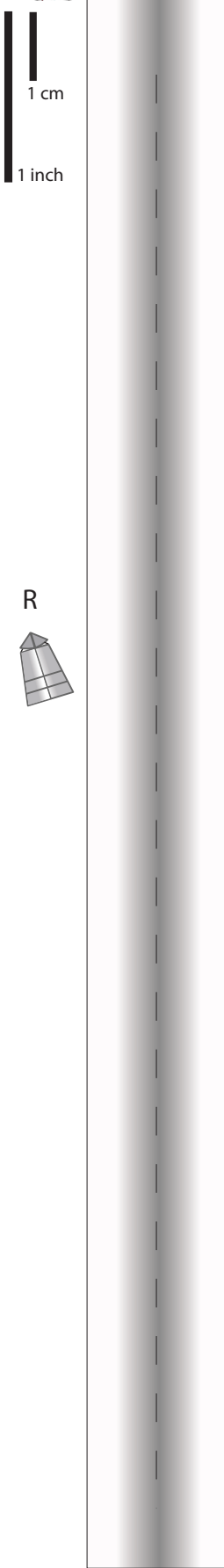

1 cm

1 inch

R

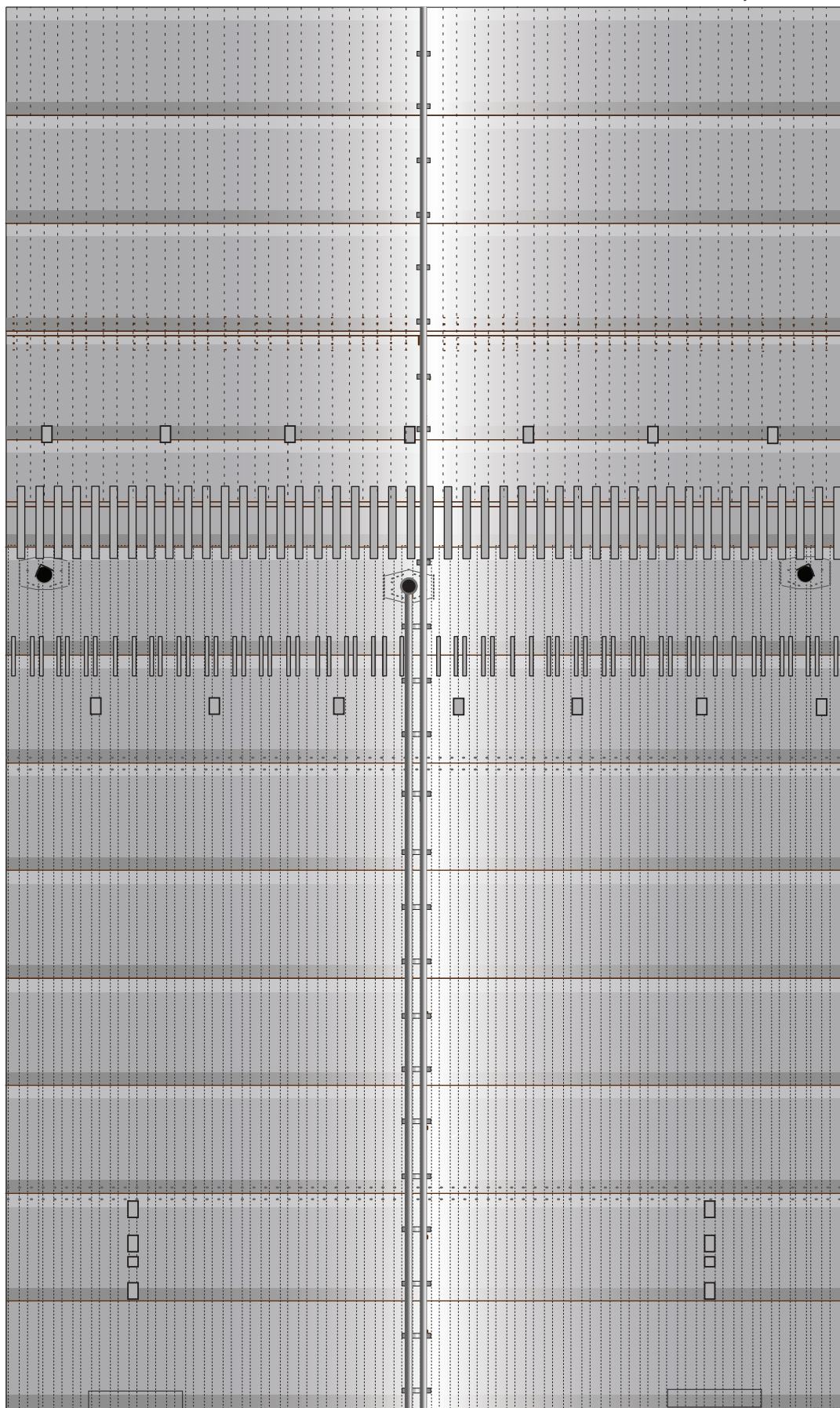

L





1:100 Scale

# Booster 15

Print on Cardstock (110 lbs)  
Back side middle

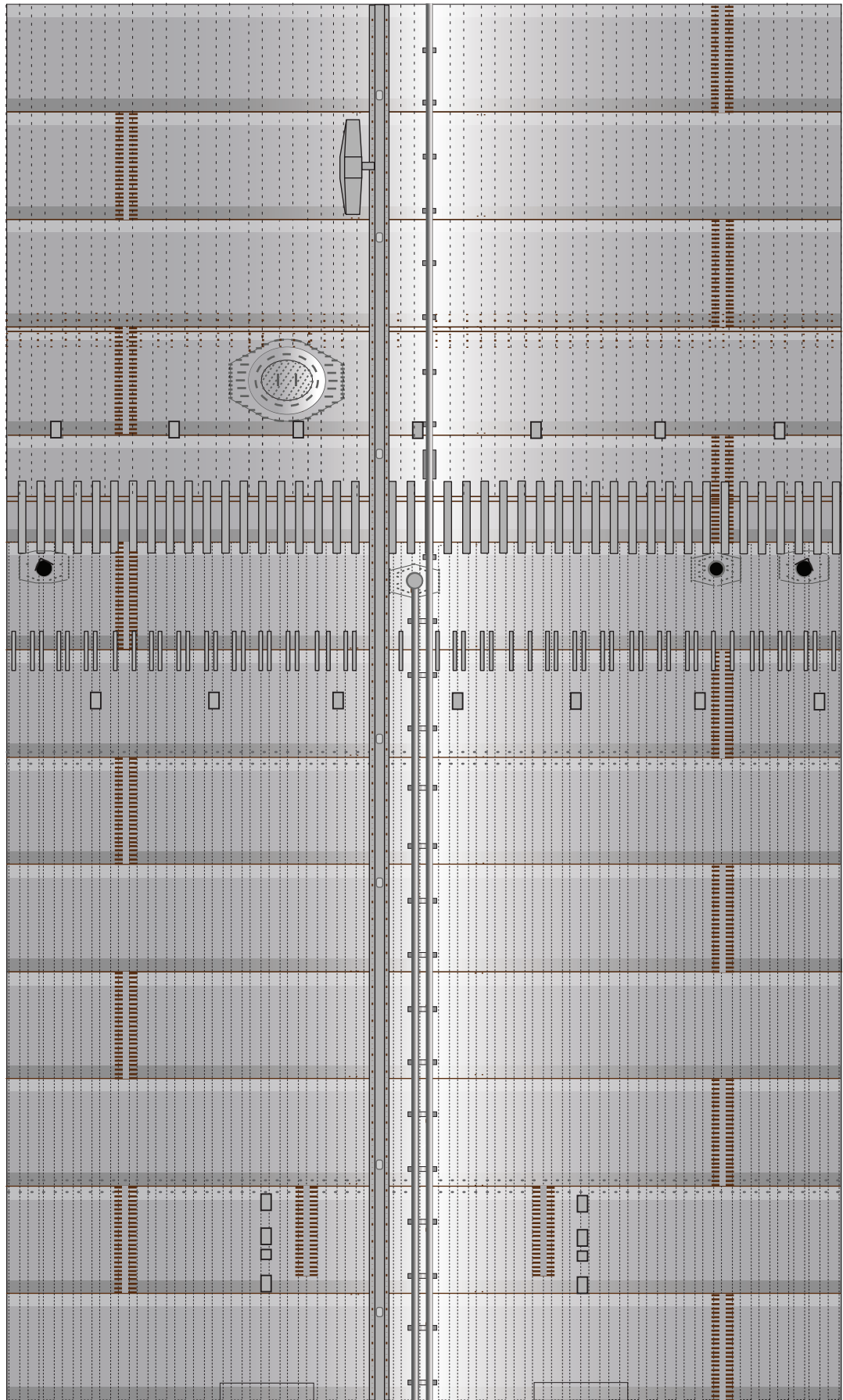





1:100 Scale

# Booster 15

Print on Cardstock (110 lbs)

Belly side bottom

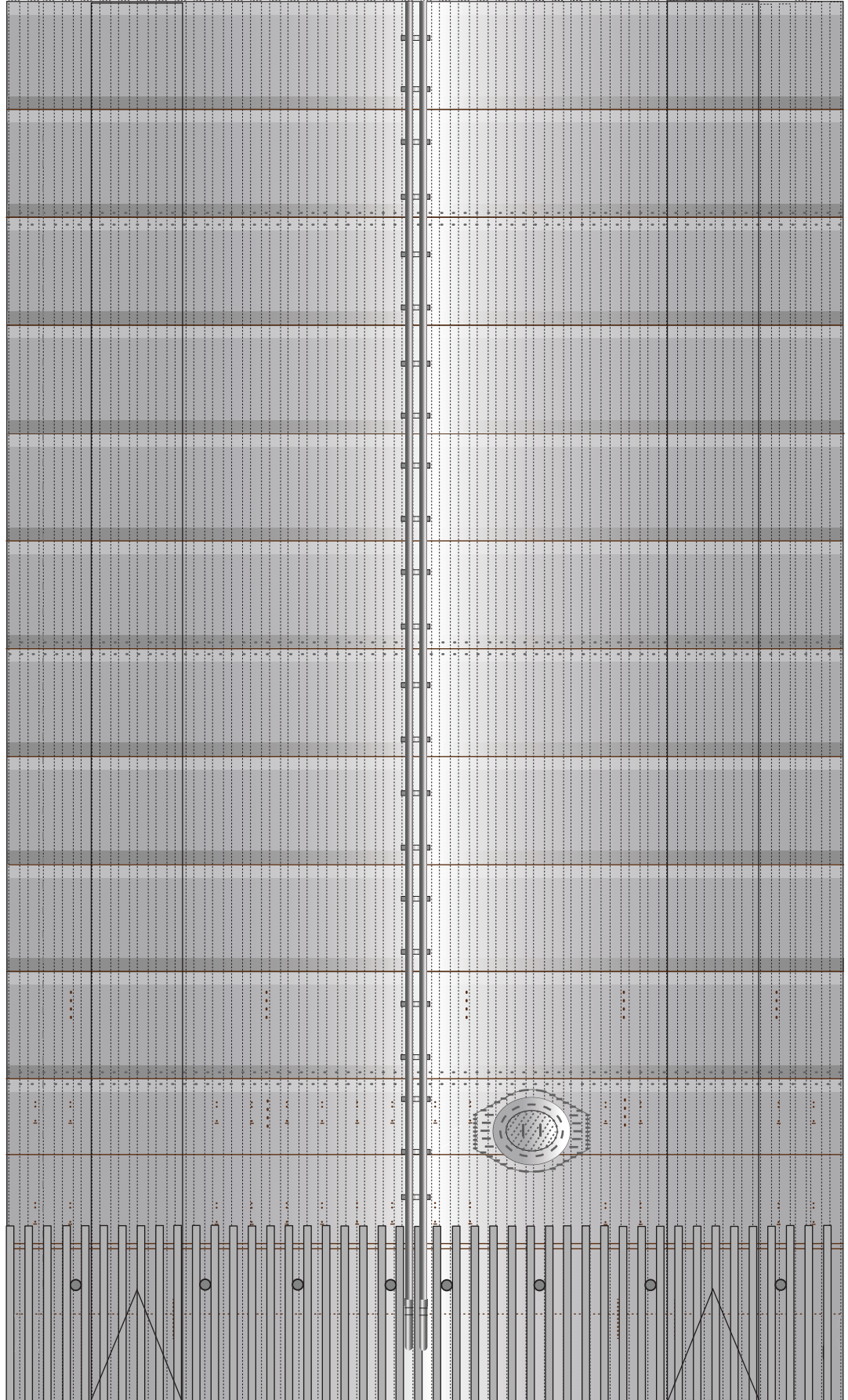
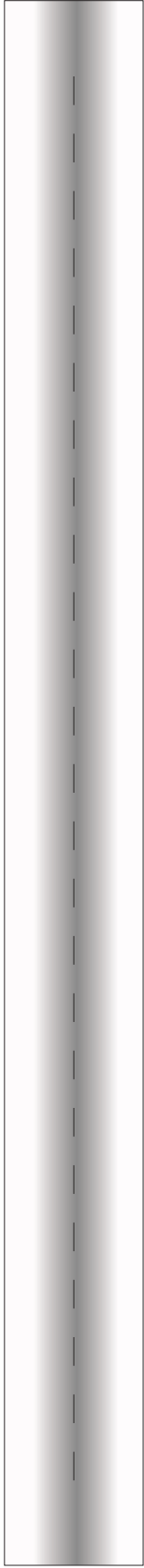



1:100 Scale

# Booster 15

Print on Cardstock (110 lbs)  
Back side bottom

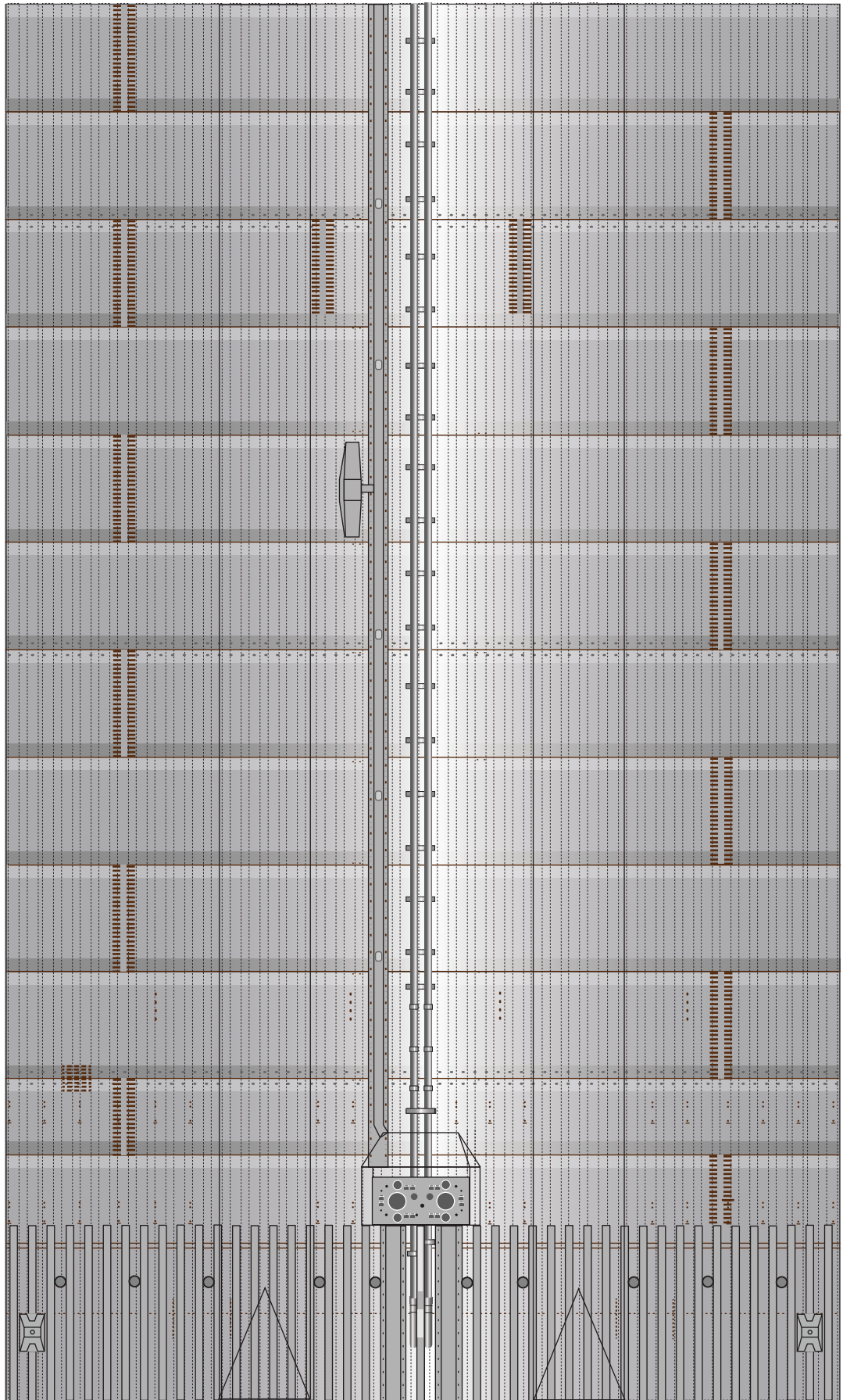
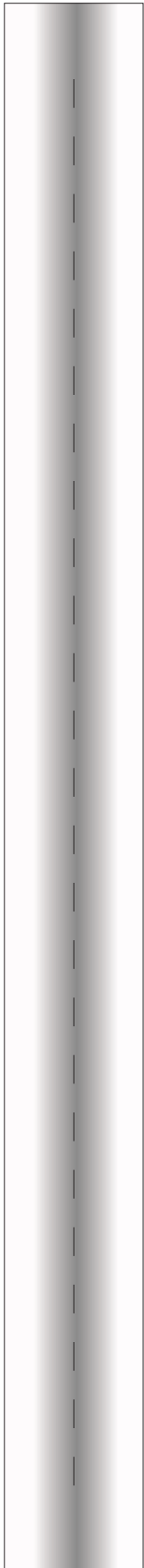



1:100 Scale



# SuperHeavy Booster

Print on cardstock (110 lbs)

## COPV covers

FRONT

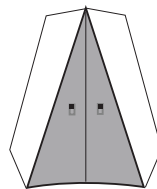
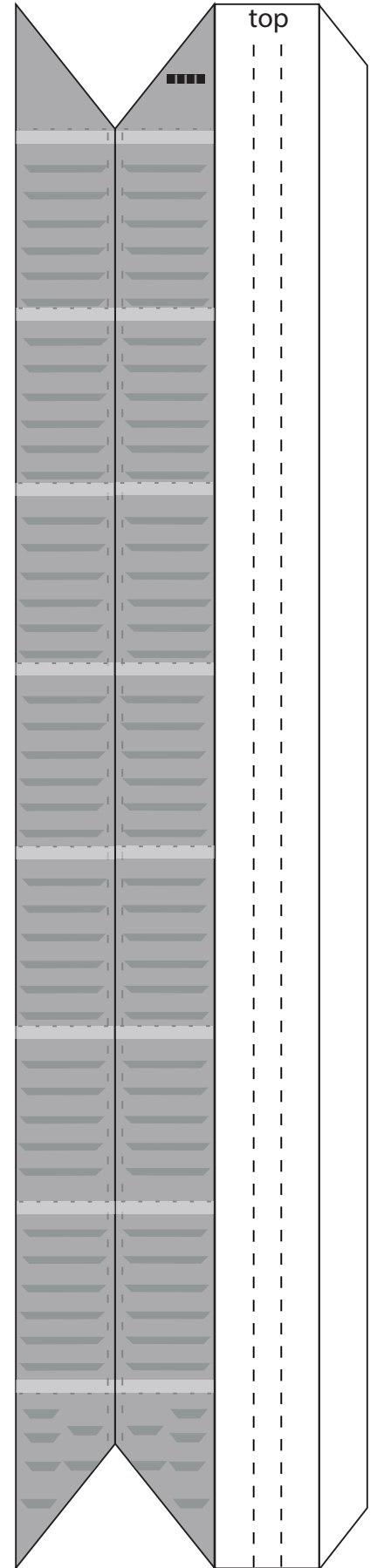
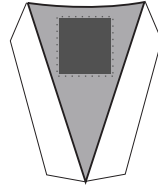
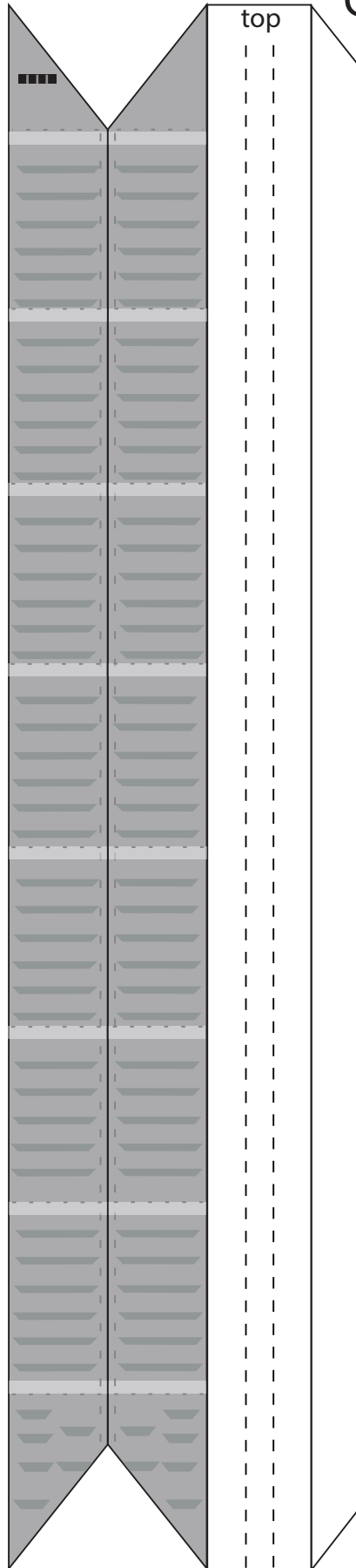
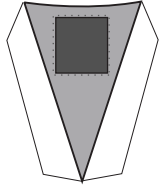



1:100 Scale



# SuperHeavy Booster

Print on cardstock (110 lbs)

## COPV covers

Umbilical side

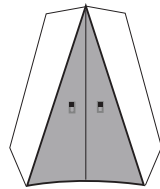
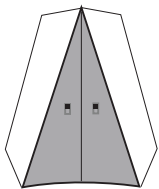
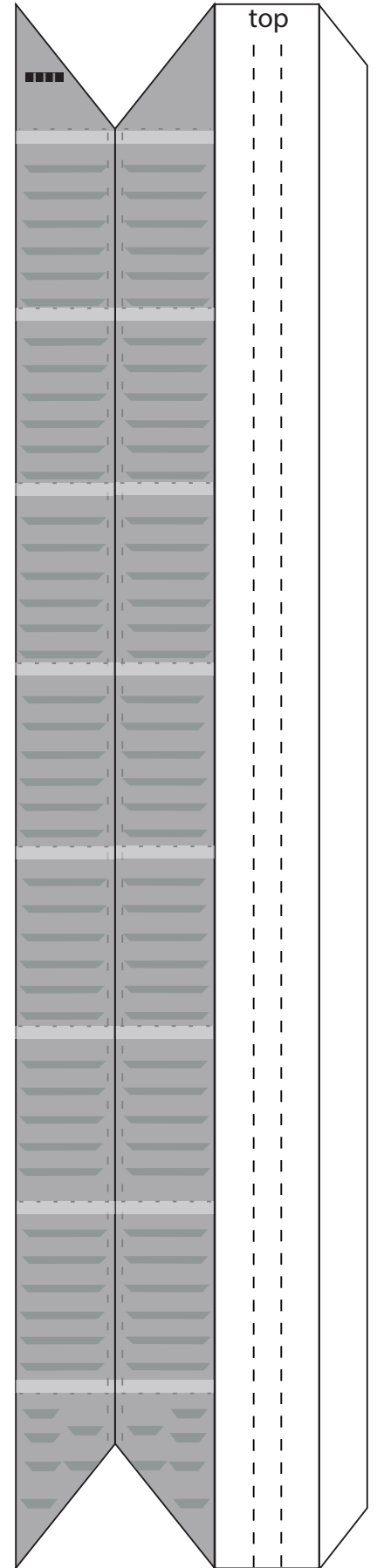
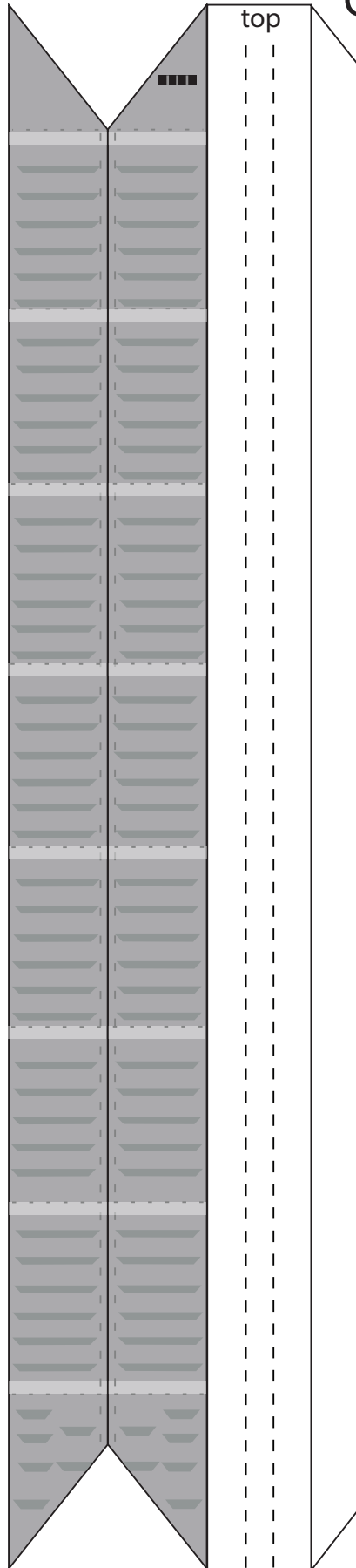
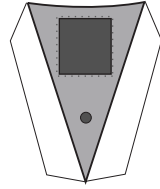
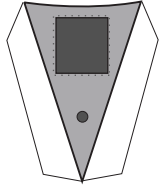



1:100 Scale

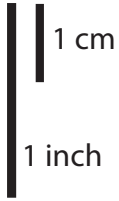

# SuperHeavy Booster

## Formers for top section

Print on Cardstock (110 lbs)

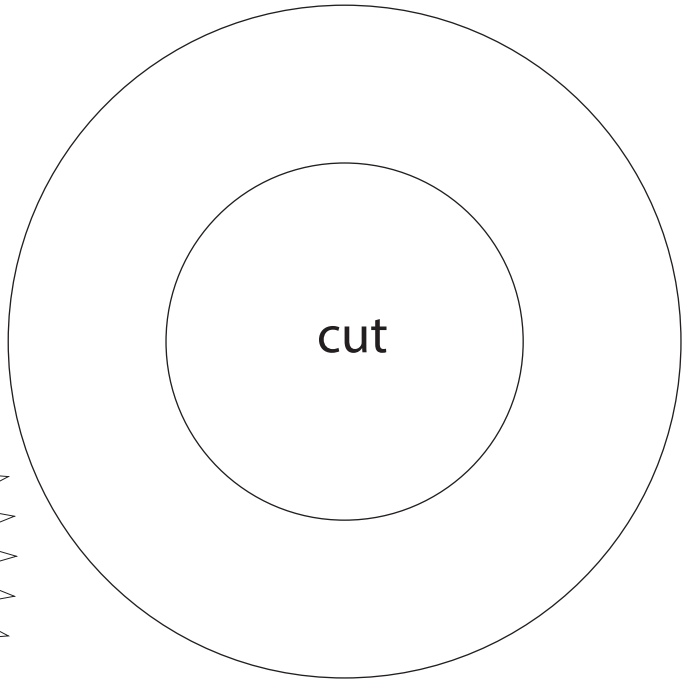
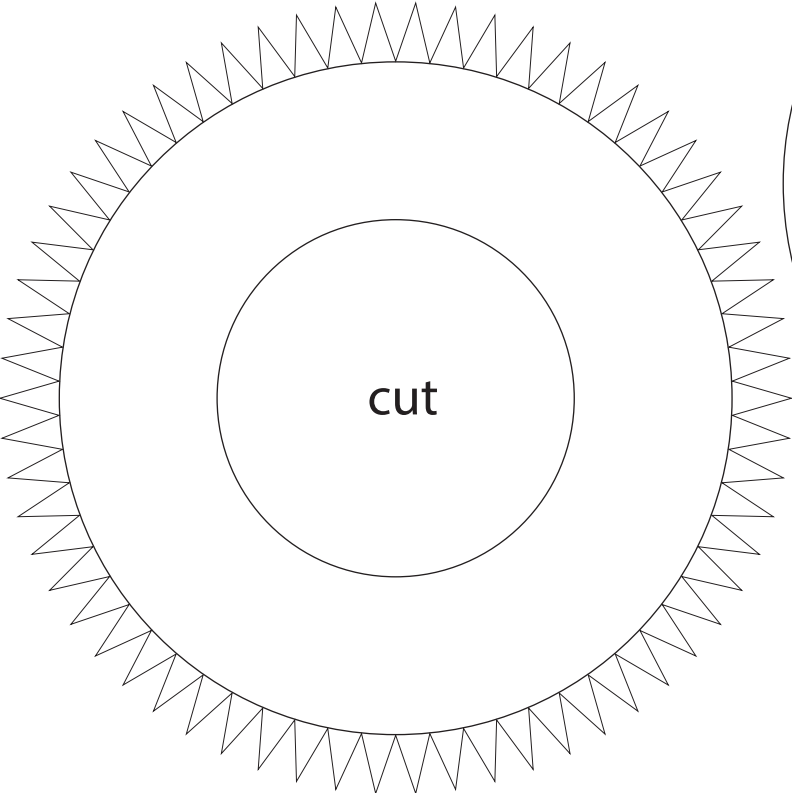
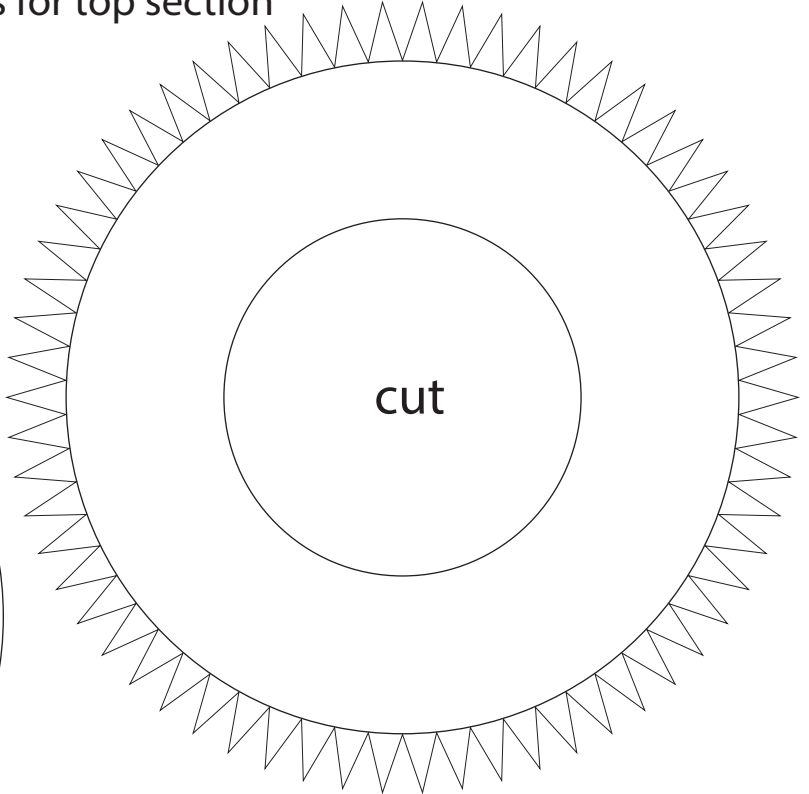
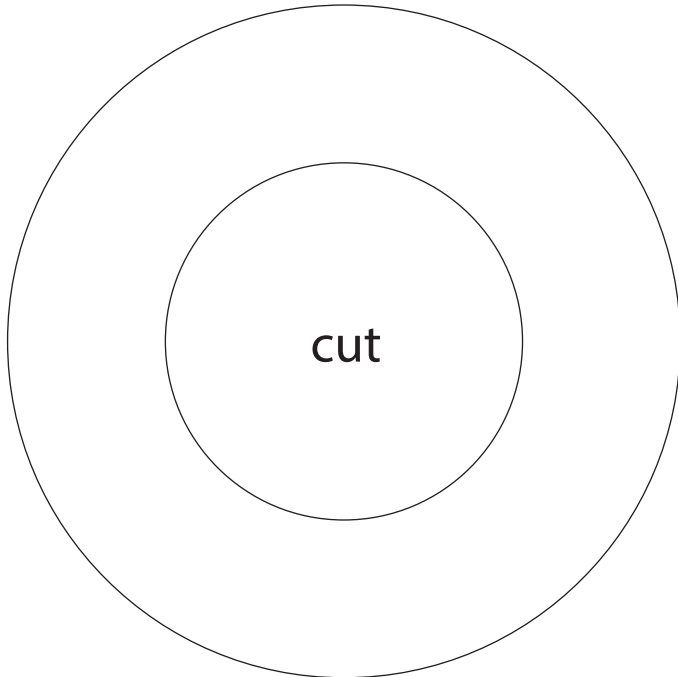

**IMPORTANT**  
Top former is glued 42 mm from top edge of top booster section.  
Bottom former is glued 20 mm from bottom edge of top booster section.



1:100 Scale



# SuperHeavy Booster

Print on Cardstock (110 lbs)

## Formers for middle body

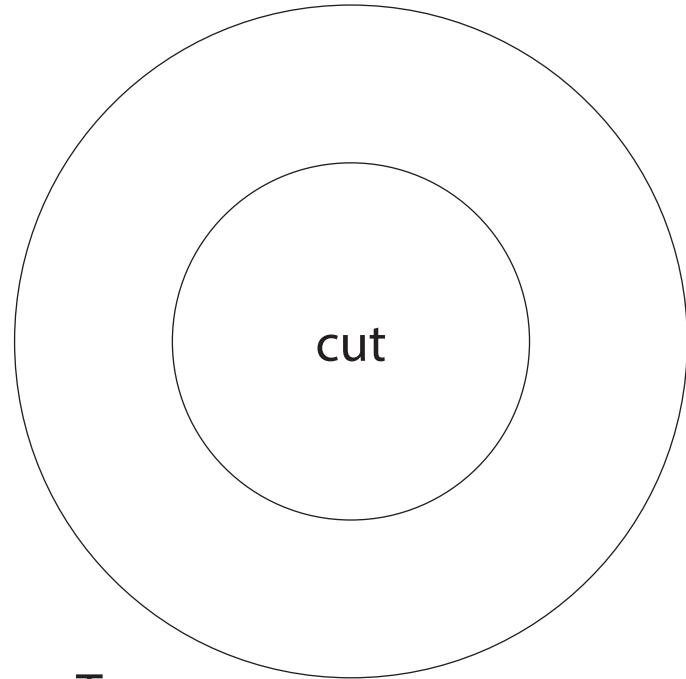

Top

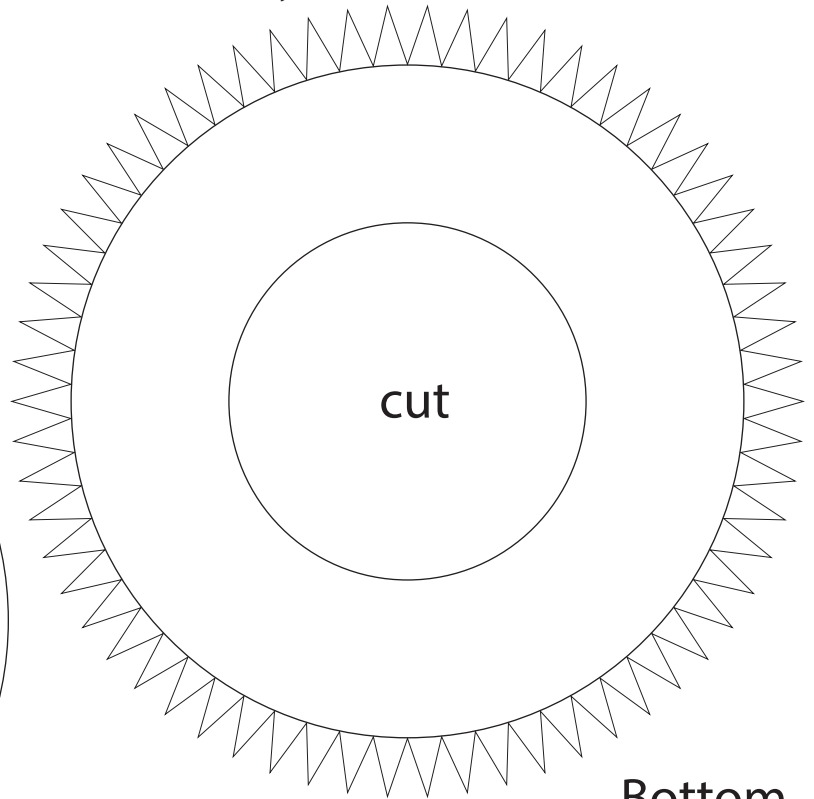

Bottom

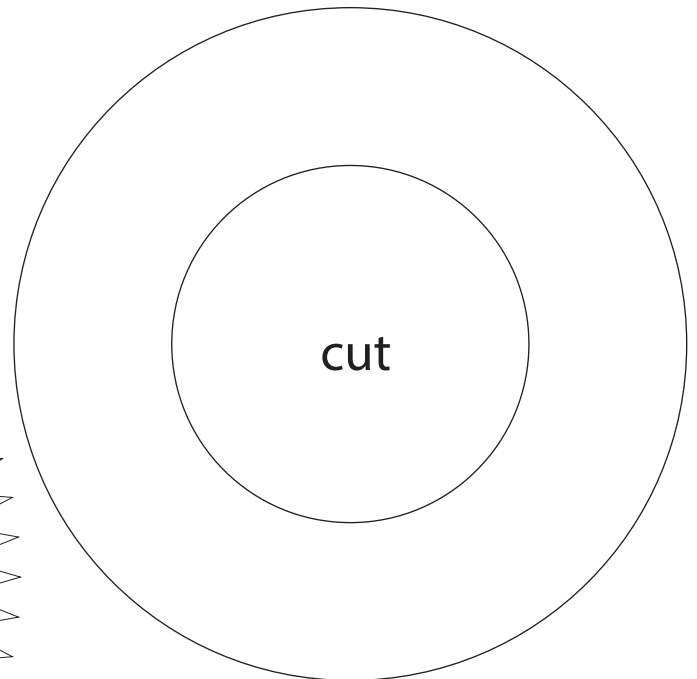
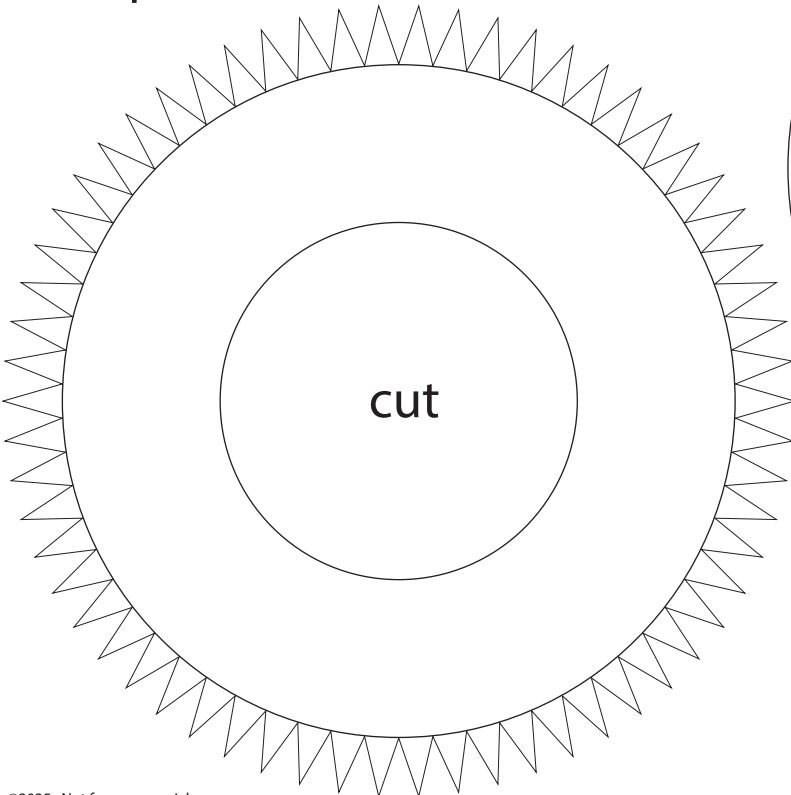

### IMPORTANT

Top former is glued 20 mm from top edge of middle booster section.  
Bottom former is glued 20 mm from bottom edge of middle booster section.



1:100 Scale

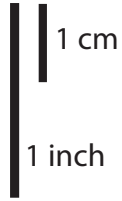

# SuperHeavy Booster

Print on Cardstock (110 lbs)

## Formers for bottom body

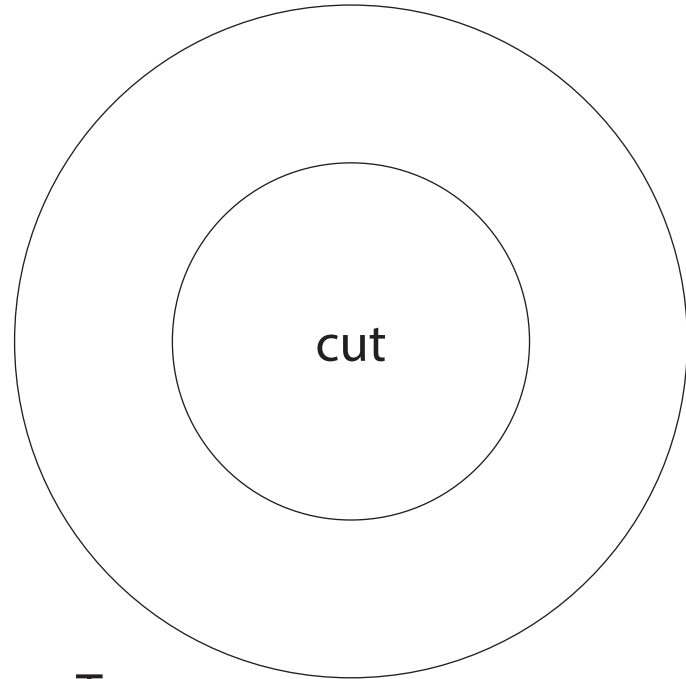

Top

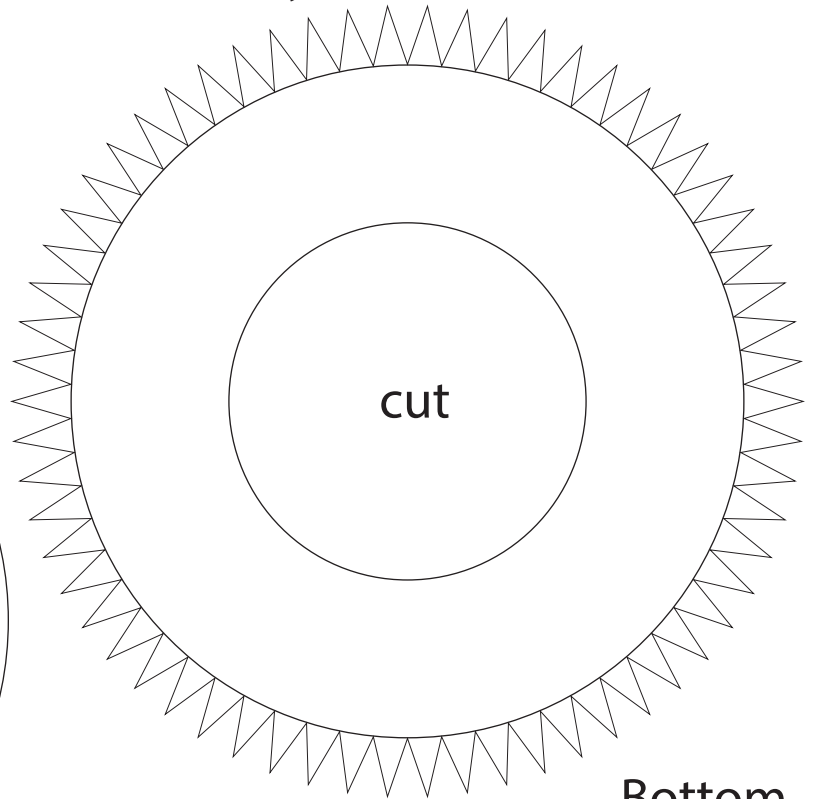

Bottom

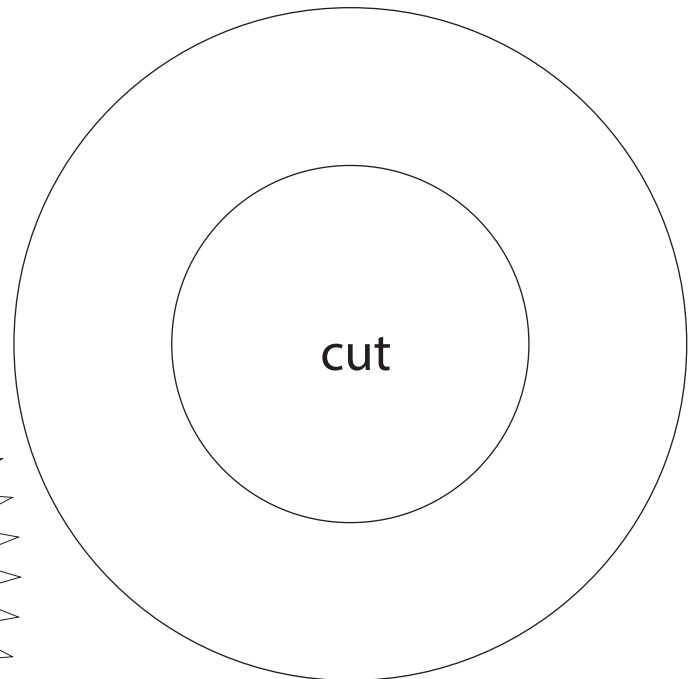
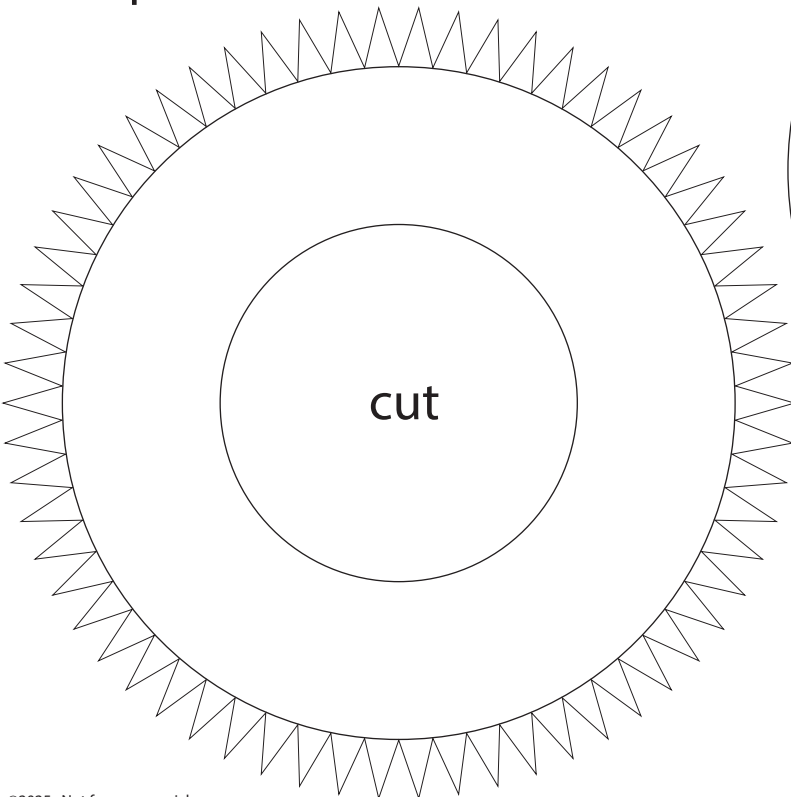

### IMPORTANT

Top former is glued 20 mm from top edge of bottom booster section.  
Bottom former is glued 19 mm from bottom edge of bottom booster section.



1 cm

1 inch

1:100 Scale

# SuperHeavy Booster

Print on Cardstock ( 110 lbs)

## Outer Raptor ring

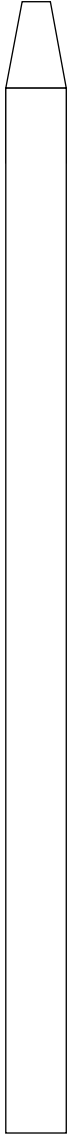
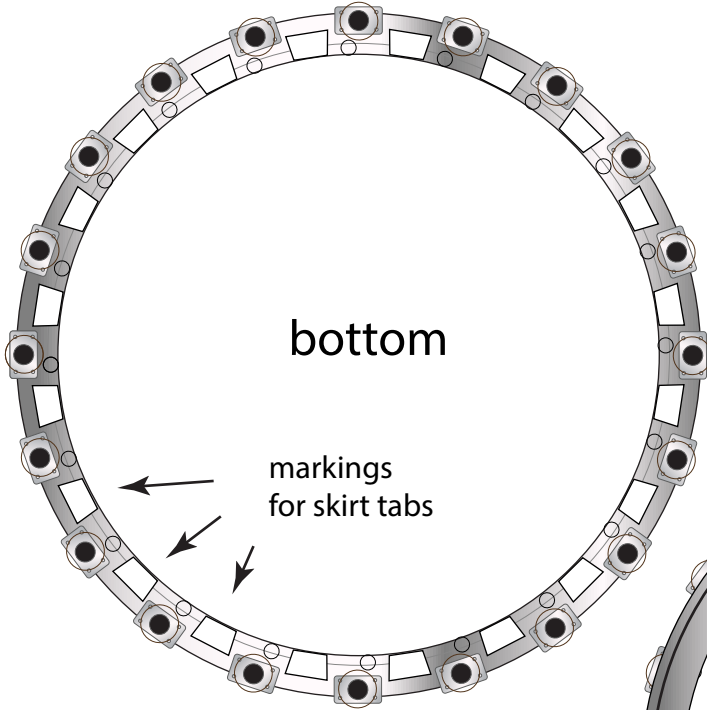

## Engine section interior layer







1:100 Scale



# SuperHeavy Booster

Print on Cardstock (90 lbs)

## Skirt for B15 engine section

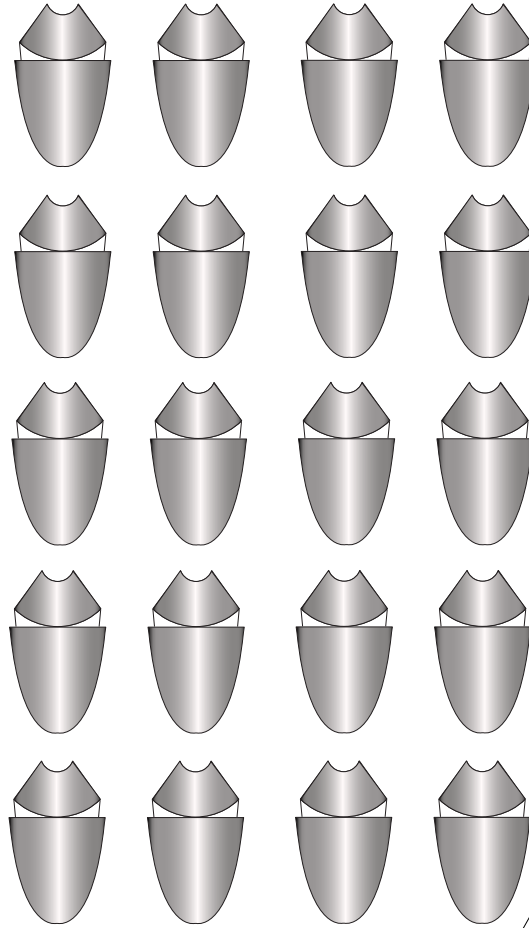
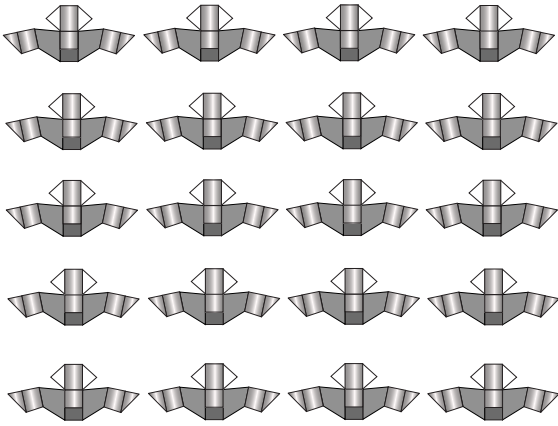

### SpaceX labels during transport

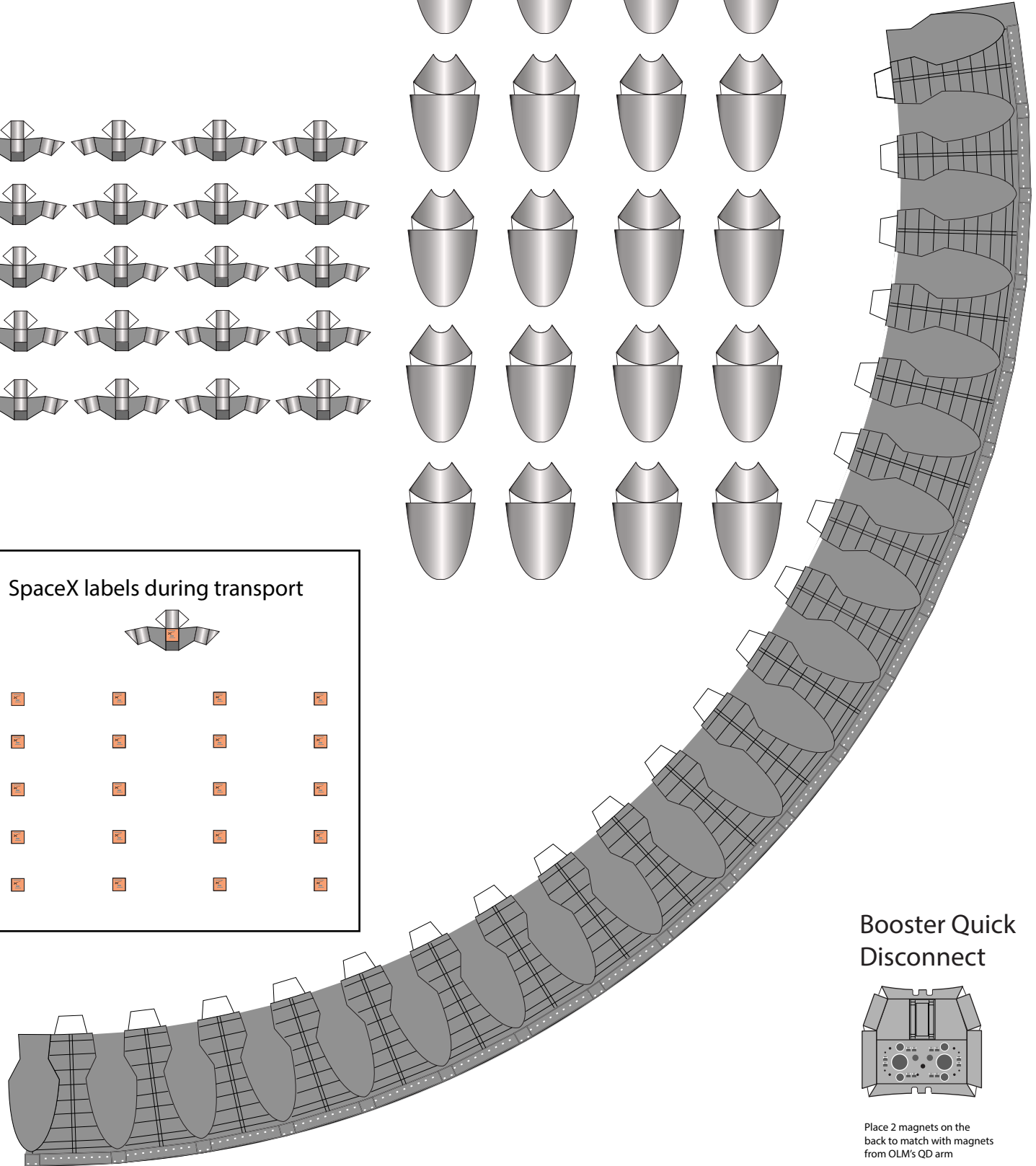
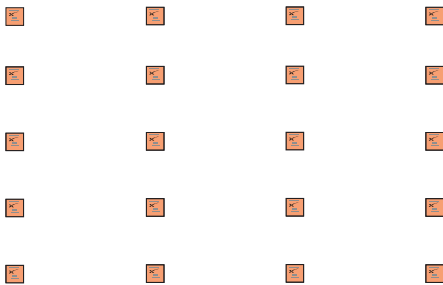
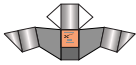

### Booster Quick Disconnect

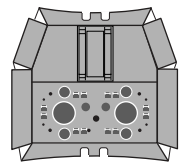

Place 2 magnets on the back to match with magnets from OLM's QD arm



1 cm

1 inch

1:100 Scale

# SuperHeavy Booster

## Skirt floor and wall

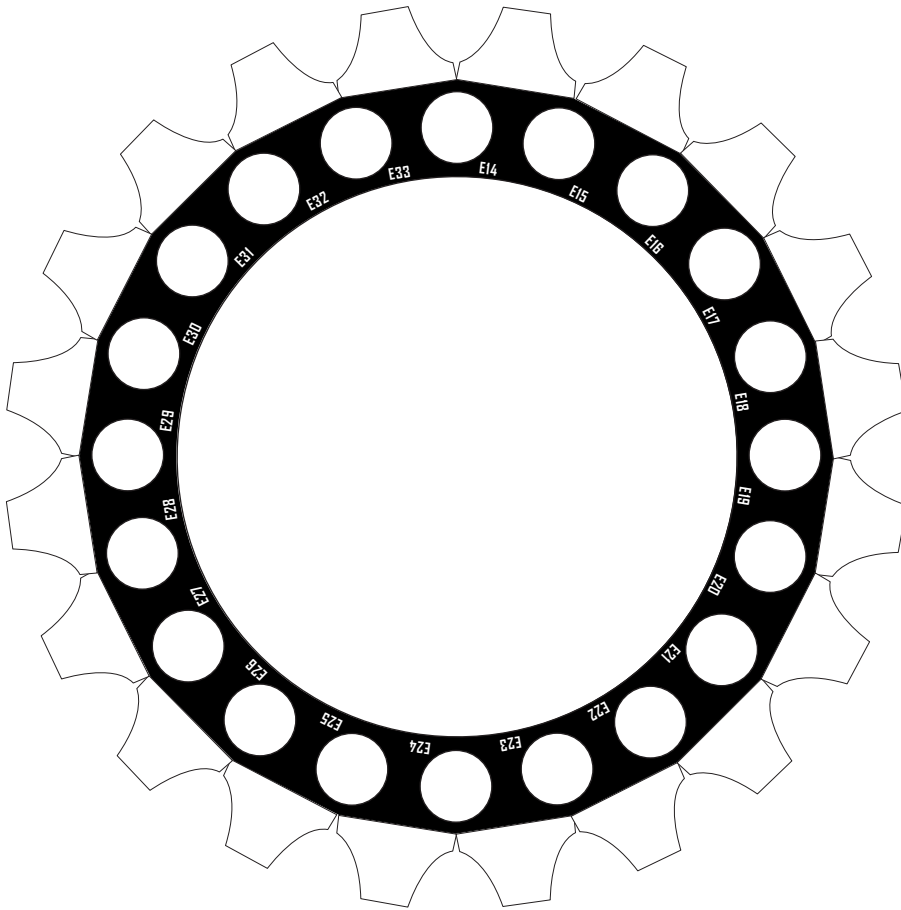

Glue Raptor base

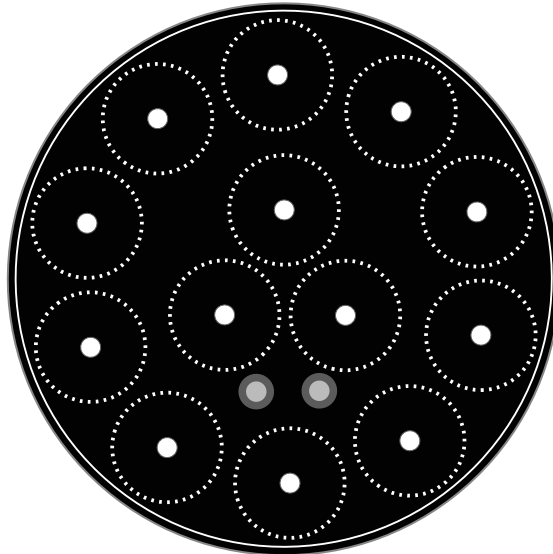

Print on Cardstock (90 lbs)

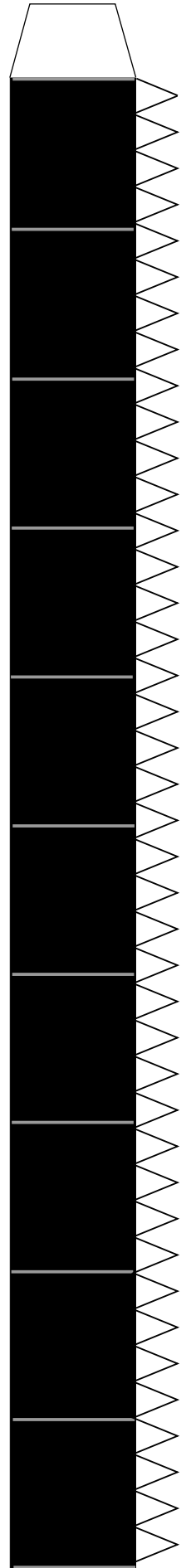



1:100 Scale



# SuperHeavy Booster

## Raptor Covers

Print on cardstock

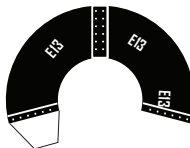
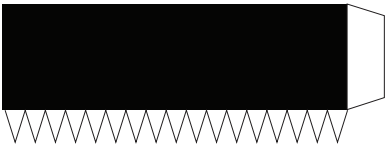
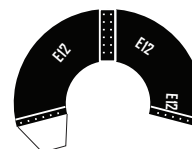
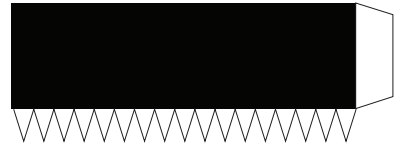
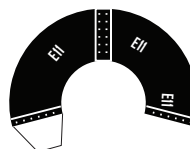
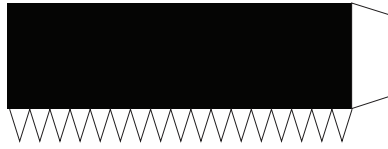
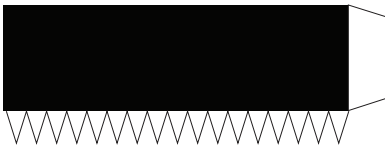
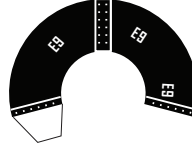
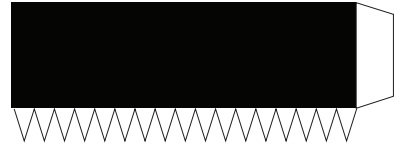
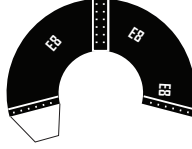
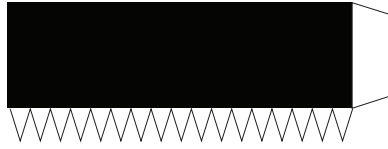
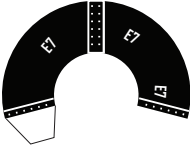
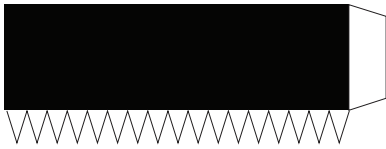
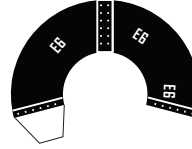
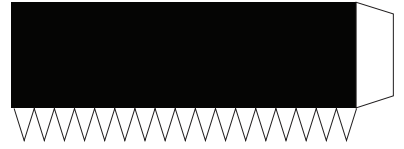
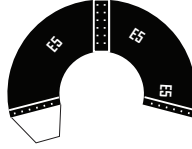
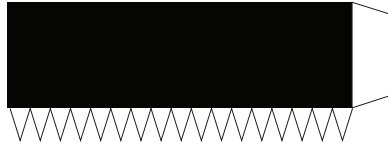
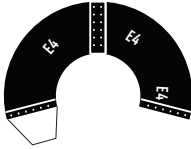
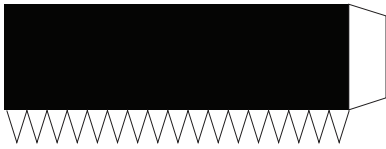
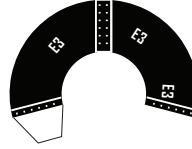
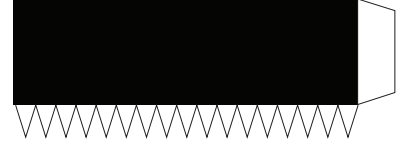
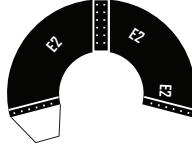
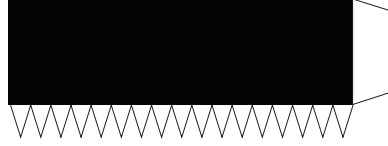
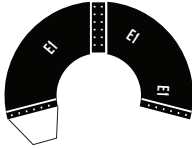
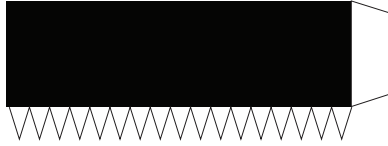



1 cm

# SuperHeavy Raptors

Print on Cardstock ( 110 lbs)

1 inch

1:100 Scale

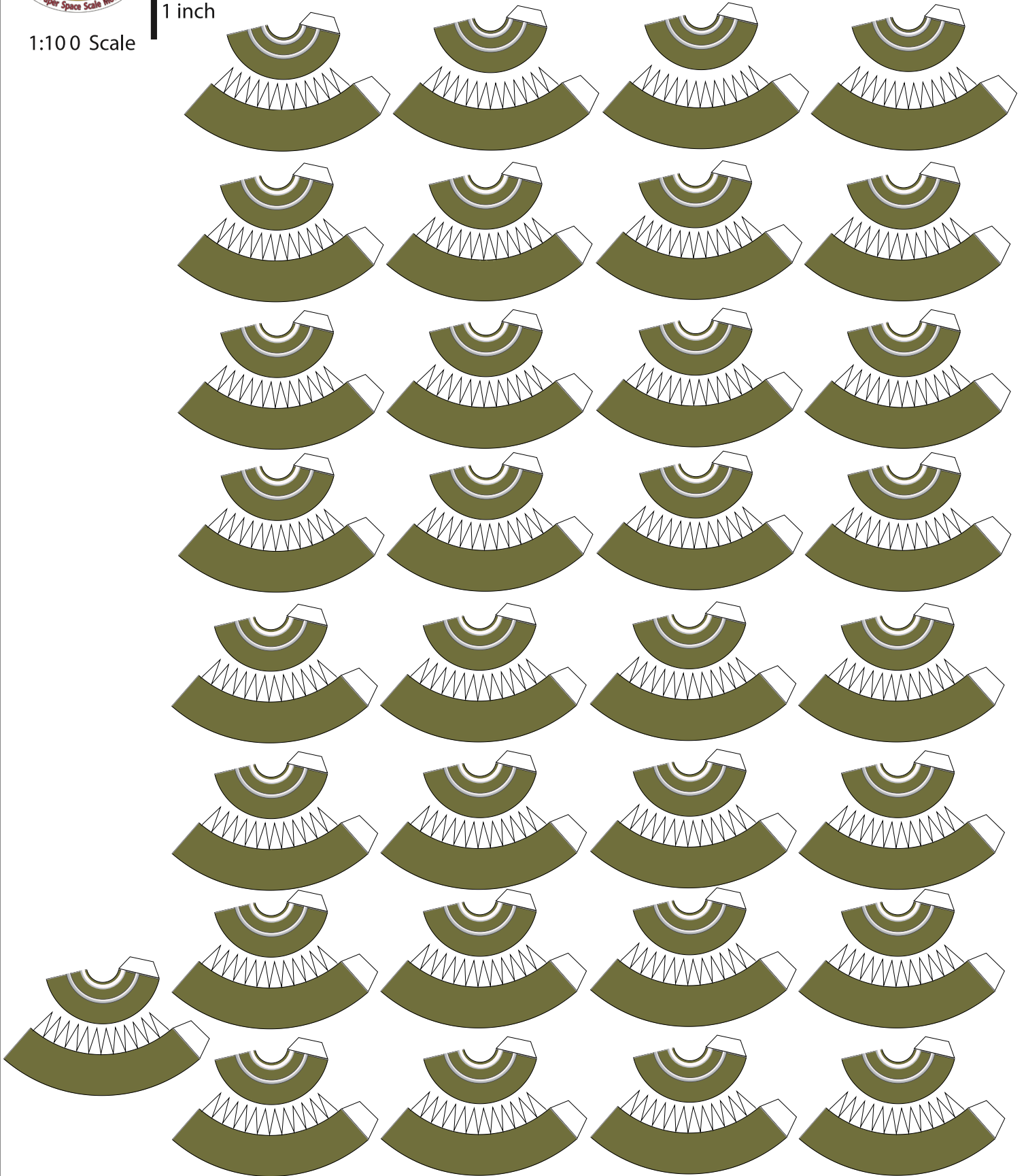



# SuperHeavy Raptors BACKPRINT

Print on Cardstock ( 110 lbs)

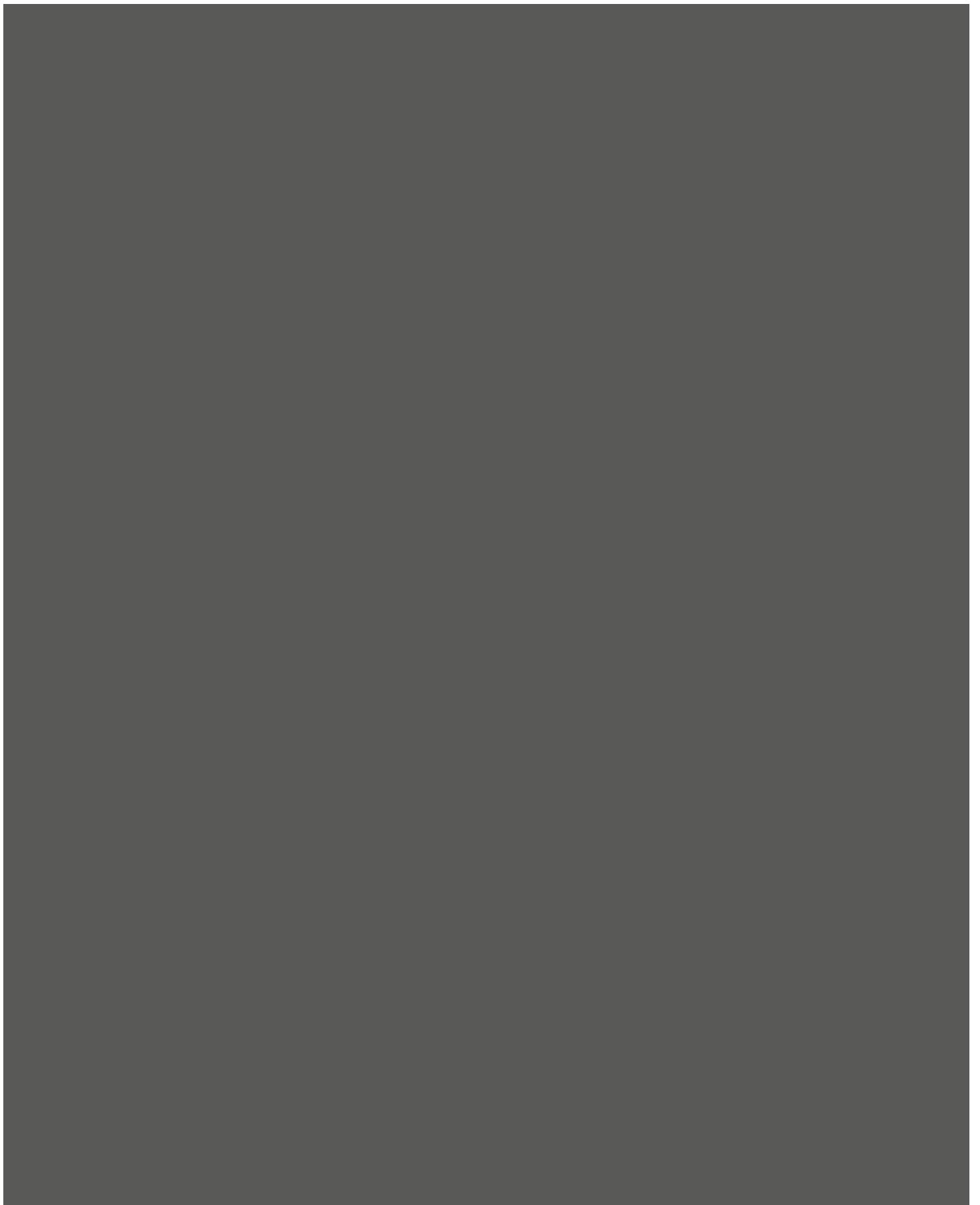



1 cm

1 inch

1:100 Scale

# SuperHeavy Booster

## Raptor location

Umbilical side

